

Downtown Improvement Project Phase II Intersections

Manchester by the Sea, Massachusetts

Prepared for **Town of Manchester by the Sea**

Prepared by **Vanasse Hangen Brustlin, Inc.
Watertown, Massachusetts**

April 17, 2019

**TOWN OF MANCHESTER BY THE SEA, MASSACHUSETTS
DOWNTOWN IMPROVEMENT PROJECT
PHASE II INTERSECTIONS**

April 17, 2019

TOWN ADMINISTRATOR

Gregory Federspiel

DIRECTOR OF PUBLIC WORKS

Chuck Dam

**VANASSE HANGEN BRUSTLIN, INC
101 WALNUT STREET / P.O. BOX 9151
WATERTOWN, MASSACHUSETTS 02472**

**TOWN OF MANCHESTER BY THE SEA, MASSACHUSETTS
DOWNTOWN IMPROVEMENT PROJECT
PHASE II INTERSECTIONS**

TABLE OF CONTENTS

	<u>PAGE</u>
TABLE OF CONTENTS	i
INVITATION TO BID	IB-1 – IB-2
INSTRUCTIONS FOR BIDDERS	IFB-1 – IFB-10
BID FORMS	BF-1 – BF-20
Bid Form	
Supplemental Form for Bid – Base Bid	
Supplemental Form for Bid – Add Alternates	
Bid Bond	
Non-Collusion and Tax Certification Form	
CONTRACT FORMS	CF-1 – CF-21
Agreement	
Performance Bond	
Payment Bond	
Notice of Award	
Notice to Proceed	
Application and Certificate for Payment	
Change Order Form	
Work Change Directive Form	
Certificate of Substantial Completion	
GENERAL CONDITIONS OF CONTRACT	GC-1 – GC-49
SUPPLEMENTARY CONDITIONS	SC-1 – SC-18
SPECIAL PROVISIONS	SP-1 – SP-33
PREVAILING WAGE RATES	WR-1 – WR-42

INVITATION TO BID

TOWN OF MANCHESTER BY THE SEA, MASSACHUSETTS
DOWNTOWN IMPROVEMENT PROJECT
PHASE II INTERSECTIONS

INVITATION TO BID

Sealed Bids for the Downtown Improvement Project Phase II Intersections project will be received by the Department of Public Works, 10 Central Street, Manchester by the Sea, MA 01944 on **Wednesday May 8, 2019 at 11:00 AM**, and at that time and place (Room 5) bids will be publicly opened and read aloud.

The bids shall be addressed to Chuck Dam, Public Works Director, Department of Public Works, 10 Central Street, Manchester by the Sea, MA 01944 and shall be prepared in accordance with the Bid Documents.

The work under this Contract consists of Complete Streets intersection improvements - such as curb extensions and sidewalk bump outs, relocated crosswalks, and reallocation of on-street parking - at three separate intersections in Manchester-by-the-Sea, MA.

Project Location #1 is the intersection of Central Street, Union Street, School Street, and Church Street. Project Location #2 is the intersection of Beach Street and Union Street. Project Location #3 is the intersections of Summer Street, Sea Street, and Washington Street. The work includes sidewalks, wheelchair ramps, driveways, unclassified excavation, drainage, granite curb and edging, pavement markings, signs, landscaping and other incidental work. The Contract Time shall be 60 calendar days commencing ten (10) days following the effective date of the Agreement.

Contract Documents will be available on Wednesday April 17, 2019 on the Town of Manchester by the Sea website (<https://www.manchester.ma.us/629/Bids-Quotes-and-Proposals>).

Each Bid shall be submitted in accordance with the Instructions to Bidders and be accompanied by a Bid Security in the amount of 5 percent of the Bid.

No Bidder may withdraw his/her Bid for a period of sixty days (60), excluding Saturdays, Sundays, and legal holidays, after the actual date of the opening of the Bids.

The Successful Bidder must furnish a 100 percent Construction Performance Bond and a 100 percent Construction Payment Bond with a surety company acceptable to the Owner.

Complete instructions for filing Bids are included in the Instructions to Bidders.

The minimum wage rates to be paid by the Contractor on this work shall be as determined by the Massachusetts Department of Labor Standards as per M.G.L., Chapter 149, Section 26 to 27D inclusive. The schedule of wage rates is included in the bid documents.

All bids for this project are subject to applicable public bidding laws of Massachusetts, including General Laws Chapter 30, Section 39M as amended. Attention is directed to the minimum wage rates to be paid as determined by the Commissioner the Department of Labor Standards under the provisions of Massachusetts General Laws, Chapter 149, Section 26 and 27D inclusive.

The Owner reserves the right to waive any informality in or to reject any or all Bids if deemed to be in their best interest.

All Bids will be evaluated on the basis of the Base Bid price (pages BF-2 to BF-6), plus the sum of Add Alternate Bid prices (page BF-7 to BF-16), listed in order of importance, as accepted by the Town of Manchester by the Sea, as further detailed in the Bidding Documents. The Base Bid shall consist of all work at the Summer Street, Sea Street, & Washington Street intersection (Project Location #3). Add Alternates consist of:

- Add Alternate No. 1 – Central St / Union Street & School Street Intersection (Project Location #1)
- Add Alternate No. 2 – Beach Street & Union Street Intersection (Project Location #2)

Bidders shall be pre-qualified through the Prequalification Office of the Massachusetts Department of Transportation, 10 Park Plaza, Boston, Massachusetts. Contractors intending to bid on this project must complete the Pre-Qualification criteria and process as defined on the MassDOT Website indicated below, and as further defined in the Bid Documents:

<https://www.mass.gov/prequalification-of-horizontal-construction-firms>

GREGORY FEDERSPIEL
TOWN ADMINISTRATOR
TOWN OF MANCHESTER BY THE SEA, MA

INSTRUCTIONS FOR BIDDERS

TOWN OF MANCHESTER BY THE SEA, MASSACHUSETTS
DOWNTOWN IMPROVEMENT PROJECT
PHASE II INTERSECTIONS

INSTRUCTIONS FOR BIDDERS

ARTICLE 1. QUALIFICATIONS OF BIDDERS

1.1 Bidders may be investigated by OWNER to determine if they are qualified to perform the Work. All Bidders shall be prepared to submit within five days of OWNER'S or ENGINEER's request, written evidence of such information and data necessary to make this determination.

1.2 The investigation of a Bidder will seek to determine whether the organization is adequate in size, is authorized to do business in the jurisdiction where the project is located, has had previous experience and whether available equipment and financial resources are adequate to assure OWNER that the Work will be completed in accordance with the terms of the Agreement. The amount of other work to which the Bidder is committed may also be considered.

1.3 In evaluating Bids, OWNER will consider the qualifications of only those Bidders whose Bids are in compliance with the prescribed requirements.

1.4 OWNER reserves the right to reject any Bid if the evidence submitted by, or the investigation of, such Bidder fails to satisfy OWNER that such Bidder is properly qualified to carry out the obligations of the Contract Documents and to complete the Work contemplated therein.

1.5 The Contractor shall be pre-qualified and approved in highway construction by the Commonwealth of Massachusetts prior to bidding on this project. MassDOT will provide the Town of Manchester by the Sea with a list of Approved Bidders prior to the Bid Opening and only Contractors listed on the approved list will be eligible to bid on the project. The Prequalification process is further defined below:

This project is subject to the requirements of Chapter 29, Section 8B of the Massachusetts General Laws whereby each prospective Bidder proposing to bid on any work to be awarded by a municipality under the provisions of Section 34 of Chapter 90, must be prequalified in accordance with 720 CMR 5.00, "Prequalification of Contractors". It should be noted that this applies to horizontal construction only.

To ensure compliance with these regulations the community is required to adhere to the revised procedures as follows:

1. When a project is advertised for bids the municipality must send an email of the advertisement to MassDOT's Prequalification Office at: prequal.r109@state.ma.us.
2. The Prequalification Office will email the municipality an official contractor bid list for all contractors prequalified in the specified class of work with a single contract limit at or above the dollar value of the project. The Prequalification Office will also email a waiver contractor bid list for those contractors that have been granted a waiver by the Prequalification Committee to bid the project. Updated official and

waiver lists will be emailed to the municipality periodically and the day before the bid opening for the project.

3. Bidders may obtain plans and specifications from the municipality at the place specified in the Notice to Contractors but may not obtain an Official Proposal Book without being listed in the official or waiver contractor lists issued by MassDOT Prequalification Office.

Please note, the revised procedures no longer require R109 forms be submitted to MassDOT nor will approval forms be generated for individual contractors.

If you have any questions regarding the revised procedure please direct them to prequel.r109@state.ma.us or the MassDOT Prequalification Department Hotline at 857-368-8660.

Contractors seeking “INFORMATIONAL ONLY” bid documents are not required to follow aforementioned procedures.

Bidders shall be pre-qualified through the Prequalification Office of the Massachusetts Department of Transportation, 10 Park Plaza, Boston, Massachusetts. Contractors intending to bid on this project must complete the Pre-Qualification criteria and process as defined on the MassDOT Website indicated below, and as further defined in the Bid Documents:

<https://www.mass.gov/prequalification-of-horizontal-construction-firms>

ARTICLE 2. COPIES OF CONTRACT DOCUMENTS

2.1 Complete sets of Contract Documents shall be used in preparing Bids; neither OWNER nor ENGINEER assume any responsibility for errors or misinterpretations resulting from the use of incomplete sets of Contract Documents.

2.2 OWNER and ENGINEER in making copies of Contract Documents available do so only for the purpose of obtaining Bids on the Work and do not confer a license or grant for any other use.

ARTICLE 3. EXAMINATION OF CONTRACT DOCUMENTS AND SITE

3.1 Before submitting a Bid, each Bidder must (a) examine the Contract Documents thoroughly, (b) visit the site to familiarize himself with local conditions that may in any manner affect cost, progress or performance of the Work, (c) familiarize himself with Federal, State and local laws, ordinances, rules and regulations that may in any manner affect cost, progress or performance of the Work; and (d) study and carefully correlate Bidder's observations with the requirements of the Contract Documents.

3.2 Before submitting his/her Bid, each Bidder may, at his/her own expense, make such additional investigations and tests as the Bidder may deem necessary to determine his/her Bid for performance of the Work in accordance with the time, price and other terms and conditions of the Contract Documents.

© 2019 VHB Inc,
All Rights Reserved

3.3 The lands upon which the Work is to be performed, rights-of-way for access thereto and other lands designated for use by CONTRACTOR in performing the Work are identified in the Supplementary Conditions, General Requirements or on the Drawings.

3.4 The submission of a Bid will constitute an incontrovertible representation by the Bidder that he/she has complied with every requirement of this Article 3 and that the Contract Documents are sufficient in scope and detail to indicate and convey understanding of all terms and conditions for performance of the Work.

ARTICLE 4. INTERPRETATIONS

4.1 All questions about the meaning or intent of the Contract Documents shall be directed via email only to Nathan Desrosiers at DPW (desrosiersn@manchester.ma.us), at least ten (10) days before the date herein set for the opening of bids.

4.2 Written clarifications or interpretations will be issued by Addenda not later than five (5) days before the bid opening date. Only questions answered by formal written Addenda will be binding. Oral and other clarifications or interpretations will be without legal effect. Addenda will be posted to the Town of Manchester by the Sea website (<https://www.manchester.ma.us/629/Bids-Quotes-and-Proposals>).

4.3 Any and all such interpretations and any supplemental instructions will be in the form of written addenda to the Contract Documents which, when issued, will be sent via e-mail to all prospective bidders on record as having requested the bid package (at the respective address furnished by them for such purposes). All bidders shall include with their bids written acknowledgement of receipt of all addenda. Failure of any bidder to receive any such addendum or interpretation shall not relieve such bidder from any obligation under this bid as submitted. All addenda so issued shall become part of the Contract Documents.

All Bidders must provide a clearly written and valid e-mail address at the time they obtain the Bid Documents. Failure to supply a valid e-mail address may, at the Town's Discretion, disqualify the contractor's bid.

4.4 Each Bidder shall be responsible for determining that he/she has received all Addenda issued.

4.5 The OWNER considers any information, which may have been released either orally or in writing prior to the issuance of this Project Manual, to be preliminary in nature and shall not be bound by such information.

ARTICLE 5. PRE-BID CONFERENCE

5.1 A pre-bid conference is not contemplated for this project.

ARTICLE 6. BID SECURITY

6.1 Each Bid must be accompanied by cash, bid bond, or a certified check on, or a treasurer's or cashier's check issued by, a responsible bank or trust company, payable to OWNER. The Bid Security shall be in the amount stated in the Invitation to Bid. Bid Security shall be sealed in a separate envelope from the Bid and then attached to the envelope containing the Bid. All Bid Securities except those of the three lowest responsible and eligible Bidders will be returned within five days, Saturdays, Sundays, and legal holidays excluded, after

opening of the Bids. All Bid Securities will be returned on the execution of the Agreement or if no award is made, within thirty days, excluding Saturdays, Sundays and legal holidays after the actual date of opening of the Bids, unless forfeited under the conditions herein stipulated.

6.2 In case a party to whom a Contract is awarded shall fail or neglect to execute the Agreement and furnish the satisfactory bonds within the time specified, OWNER may determine that the Bidder has abandoned the Contract, and thereupon the Bid Forms and acceptance shall be null and void and the Bid Security accompanying the Bid Form shall be forfeited to OWNER as liquidated damages for such failure or neglect and to indemnify said OWNER for any loss which may be sustained by failure of the Bidder to execute the Agreement and furnish the bonds as aforesaid, provided that the amount forfeited to OWNER shall not exceed the difference between the Bid Price of said Bidder and that of the next lowest responsible and eligible bidder and provided further that, in case of death, disability, or other unforeseen circumstances affecting the Bidder, such Bid Security may be returned to him. After execution of the Agreement and acceptance of the bonds by OWNER, the Bid Security accompanying the Bid Form of the Successful Bidder will be returned.

ARTICLE 7. PERFORMANCE, PAYMENT AND OTHER BONDS

7.1 Performance, Payment and other Bonds shall be provided in accordance with Article 5 of the Conditions of the Contract.

7.2 All Bonds required as Contract Security shall be furnished with the executed Agreement.

ARTICLE 8. BID FORM

8.1 Each Bid shall be submitted on the Bid Form on the pages appended to the Project Manual. The Bid Form shall be removed and submitted separately. All blank spaces for Bid prices must be filled in with the unit price for the item or the lump sum for which the Bid is made.

8.2 Bid Forms shall be completed in ink or by typewriter. The Bid price of each item on the form shall be stated in words, and figures. If unit prices are required on the Bid Form, discrepancies between unit prices and their respective total amounts will be resolved in favor of the unit prices. Discrepancies between words and figures will be resolved in favor of words. Discrepancies between the indicated sum of any column of figures and the correct sum thereof will be resolved in favor of the correct sum.

8.3 Bids by corporations shall be executed in the corporate name by the president or a vice-president (or other corporate officer accompanied by evidence of authority to sign) and the corporate seal shall be affixed and attested by the secretary or an assistant secretary. The corporate address and state of incorporation shall be shown below the signature.

8.4 Bids by partnerships shall be executed in the partnership name and signed by a partner, whose title shall appear under the signature. The official address of the partnership shall be shown below the signature.

8.5 All names shall be typed or printed below the signature.

8.6 The Bid shall contain an acknowledgment of receipt of all Addenda (the numbers of which shall be filled in on the Bid Form).

8.7 The address to which communications regarding the Bid are to be directed shall be shown.

8.8 One copy of each Bid shall be submitted in a sealed opaque envelope bearing on the outside the name of Bidder, his/her address, and the Project Title for which the Bid is submitted. If forwarded by mail, Bid and sealed envelope marked as described above shall be enclosed in another envelope with the notation "BID ENCLOSED" on the face and addressed as indicated in the Invitation to Bid. The Bid Security shall be submitted in a separate envelope from the Bid and attached to the envelope containing the Bid.

ARTICLE 9. RECEIPT OF BIDS

9.1 Sealed Bids for the work of this Contract will be received at the time and place indicated in the Invitation to Bid.

9.2 OWNER may consider informal any Bid not prepared and submitted in accordance with the provisions hereof.

9.3 Bidders are cautioned that it is the responsibility of each individual bidder to assure that his/her bid is in the possession of the responsible official or his/her designated alternate prior to the stated time and at the place of the Bid Opening. Owner is not responsible for bids delayed by mail and/or delivery services, of any nature.

9.4 The Bidder must submit all of the following documents and forms to be considered responsive to this invitation to bid. Failure to submit all required documents and forms may invalidate the Bid.

Bid Form

Supplemental Form for Bid – Base Bid
Supplemental Form for Bid – Add Alternates
Bid Bond (with Power of Attorney, if applicable)
Non-Collusion and Tax Compliance Form

9.5 Should the TOWN determine that it would be in its best interest to modify the scope of proposed work, the following items may be added as an alternative to the contract, increasing the overall Base Bid.

Each General Bidder shall acknowledge Alternates by completing the section entitled “Supplemental Forms for General Bid – Add Alternate Bid Items”, entering the dollar amount of addition or subtraction necessitated by each Alternate listed in the corresponding space.

General Bidders shall enter on the “Supplemental Forms for General Bid – Add Alternate Bid Items” a single amount for each Alternate which shall consist of total of all items necessary for that Add Alternate.

In the event an Alternate does not involve a change in dollar value, the General Bidder shall so indicate by listing the individual Alternate number and acknowledge the Alternate by inserting “**No Change**”, “**No Charge**”, “**N/C**” or “**0**” in the corresponding space provided for the dollar value of that Alternate.

The Add Alternate items will be chosen in order of importance to the Town and as listed as Add Alternate 1 through 2, 1 being the most important and 2 being the least important.

The Low Bidder will be determined on the basis of the sum of the Base Bid and the accepted Add Alternates.

Base Bid – Summer Street, Sea Street, & Washington Street Intersection (Project Location #3)

The Base Bid of this Contract consists of all work defined in the Contract Documents at the Intersection of Summer Street, Sea Street, & Washington Street, defined in the Plans as “Project Location #3”.

Add Alternate No. 1 – Central / Union Street & School Street Intersection (Project Location #1)

The work under Add Alternate No. 1 consists of all work defined in the Contract Documents at the Intersection of Central Street, Union Street, School Street, and Church Street. The scope of Add Alternate No. 1 is defined in the Plans as “Project Location #1”. The items included in Add Alternate No. 1 are shown on the Contract Documents and are not provided in a separate set of design or plan documents. Separate Bid Forms are included within the Bidding Documents for the items and quantities required for Add Alternate No. 1.

Add Alternate No. 2 – Union Street & Beach Street Intersection (Project Location #2)

The work under Add Alternate No. 2 consists of all work defined in the Contract Documents at the Intersection of Beach Street and Union Street. The scope of Add Alternate No. 2 is defined in the Plans as “Project Location #2”. The items included in Add Alternate No. 2 are shown on the Contract Documents and are not provided in a separate set of design or plan documents. Separate Bid Forms are included within the Bidding Documents for the items and quantities required for Add Alternate No. 2.

ARTICLE 10. MODIFICATION AND WITHDRAWAL OF BIDS

10.1 Bids may be modified only by an appropriate document duly executed (in the manner that a Bid must be executed) and delivered to the place where Bids are to be submitted at any time prior to the opening of Bids.

10.2 Bids may be withdrawn prior to the scheduled time (or authorized postponement thereof) for the opening of Bids.

10.3 Any Bid received after the time and date specified shall not be considered. No Bidder may withdraw his/her Bid for a period of sixty days, excluding Saturdays, Sundays, and legal holidays, after the actual date of the opening of the Bids.

ARTICLE 11. AWARD OF CONTRACT

11.1 The Contract will be awarded to the lowest responsible and eligible Bidder (Successful Bidder). Such a Bidder shall possess the skill, ability, and integrity necessary for the faithful performance of the work. The term "lowest responsible and eligible Bidder" as used herein shall mean the Bidder whose Bid is the lowest of those Bidders possessing the skill, ability and integrity necessary to the faithful performance of the Work.

11.2 OWNER reserves the right to reject any and all Bids, to waive any and all informalities if it is in Owner's best interest to do so, and the right to disregard all nonconforming, nonresponsive or conditional Bids.

11.3 A Bid, which includes for any item a Bid Price that is abnormally low or high may be rejected as unbalanced.

11.4 OWNER also reserves the right to reject the Bid of any Bidder that OWNER considers to be unqualified relative to Article 1 above.

11.5 The OWNER will award the contract based on the Contract Base Bid plus the sum of the accepted Add Alternate Bids. The Add Alternate Bids will be chosen in order of importance to the OWNER and as listed as Add Alternate 1 through 2, 1 being the most important and 2 being the least important. The number of Add Alternates chosen will be determined based on the bid amounts as they compare to the total project funding amount available to the OWNER.

11.6 If the Contract is to be awarded, OWNER will give the Successful Bidder a Notice of Award within thirty (30) days, excluding Saturdays, Sundays, and legal holidays, after the actual date of the opening of the Bids. All bids shall remain open for thirty days, excluding Saturdays, Sundays, and legal holidays, after the actual date of the opening of the Bids but OWNER may, in his/her sole discretion, release any Bid and return the Bid Security prior to that date.

ARTICLE 12. TIME OF COMPLETION

The bidder must agree to commence work within ten (10) days of the date of the Notice to Proceed and to fully complete the project within the time limit hereinafter stated.

12.1 The work shall be substantially completed on or before November 30, 2018 and fully completed and ready for final payment on or before January 31, 2019. Failure to complete the work by the dates herein specified, or any proper extensions thereof granted by the OWNER, will be subject to liquidated damages.

Liquidated damages in the amount of **\$1,000.00 per day** will be assessed for each day that work has not been completed and final invoices processed, beyond **June 30, 2019**.

ARTICLE 13. EXECUTION OF AGREEMENT

13.1 When OWNER gives a Notice of Award to the Successful Bidder, it will be accompanied by at least six unsigned copies of the Agreement and all other applicable Contract Documents. Within five days, excluding Saturdays, Sundays and legal holidays, after the date of receipt of such notification CONTRACTOR shall execute and return all copies of the Agreement and all other applicable Contract Documents to OWNER. Within ten (10) days thereafter OWNER will deliver one fully signed copy to CONTRACTOR.

ARTICLE 14. SAFETY AND HEALTH REGULATIONS

14.1 This Project is subject to all of the Safety and Health Regulations (CFR 29, Part 1926 and all subsequent amendments) as promulgated by the U.S. Department of Labor on June 24, 1974 and CFR 29, Part 1910, General Industry Safety and Health Regulations Identified as Applicable to Construction.

14.2 The Successful Bidder shall comply with the Department of Labor Safety and Health Regulations for Construction promulgated under the Occupational Safety and Health Act of 1970 (PL-91-596) and under Section 107 of the Contract Work Hours and Safety Standards Act (PL-91-54).

14.3 The Successful Bidder shall have a competent person or persons, as required under the Occupational Safety and Health Act on the Site to inspect the Work and to supervise the conformance of the Work with the regulations of the Act.

ARTICLE 15. SALES TAX

15.1 The material and supplies to be used in the Work will be subject to the requirements of Paragraph 6.10 of the Conditions of the Contract.

ARTICLE 16. UTILITY UNDERGROUND PLANT DAMAGE PREVENTION SYSTEM

16.1 All excavations within public or private ways are subject to the requirements of Massachusetts General Law, Chapter 82, Section 40 included in PART II of the Supplementary Conditions.

ARTICLE 17. WAGE RATES

17.1 Minimum Wage Rates as determined by the Commissioner of Department of Labor and Industries under the provision of the Massachusetts General Laws, Chapter 149, Section 26 to 27D, as amended, apply to this project. It is the responsibility of the contractor, before bid opening, to request if necessary, any additional information on Minimum Wage Rates for those tradespeople who may be employed for the proposed work under this contract.

17.2 State schedule for minimum wage rates is included on pages WR-1 through WR-42.

ARTICLE 18. MANUFACTURER'S EXPERIENCE

18.1 Wherever it is written that an equipment manufacturer must have a specified period of experience with its product, equipment which does not meet the specified experience period can be considered if the equipment supplier or manufacturer is willing to provide a bond or cash deposit for the duration of the specified time period which will guarantee replacement of that equipment in the event of a failure. Such bond shall be an Efficiency Guarantee Bond executed on a form to be approved by the OWNER.

ARTICLE 19. COMPETITIVE BIDDING

19.1 The bidding and award of the Contract shall be in full compliance with Section 39 M inclusive of Chapter 30 of the General Laws of the Commonwealth of Massachusetts as last revised.

ARTICLE 20. GUARANTEE

20.1 The CONTRACTOR shall guarantee all materials and equipment furnished and WORK performed for a period of one year from the date of SUBSTANTIAL COMPLETION except where a longer guarantee period is required in the Project Manual. The CONTRACTOR warrants and guarantees for a period of one year, or for the longer guarantee period, from the date of SUBSTANTIAL COMPLETION of the system that the completed system is free from all defects due to faulty materials or workmanship and the CONTRACTOR shall promptly make such corrections as may be necessary by reason of such defects including the repairs of any damage to other parts of the system resulting from such defects. The OWNER will give notice of observed defects with reasonable promptness. In the event that the CONTRACTOR should fail to make such repairs, adjustments, or other WORK that may be made necessary by such defects, to the satisfaction of the OWNER within ten (10) days from the date of receipt of such notice, or having commenced fails to prosecute such WORK with diligence, the OWNER may do so and charge the CONTRACTOR the cost thereby incurred. The Performance Bond shall remain in full force and effect through the guarantee period.

ARTICLE 21. FAILURE TO PERFORM

21.1 In the case of failure on the part of the CONTRACTOR to perform the work in accordance with the contract, the Owner reserves the right to terminate the contract, and to perform or have performed any remaining work, and he will collect from or credit to the CONTRACTOR any difference in price paid by the Owner as a direct result of such failure in performance on the part of the CONTRACTOR. Exercise of the above rights shall not impair or affect the OWNER's right to recover damages for breach of contract, whether by suit on the contract or on the bond securing it. This contract is, however, made subject to strikes, acts of war, and/or other natural disasters.

ARTICLE 22. TRAFFIC CONTROL

22.1 The CONTRACTOR shall be responsible for the securing, organizing and/or cancellation of police details required by the Manchester by the Sea Police Department. The CONTRACTOR shall pay any costs incurred due to his/her failure to cancel police details. The CONTRACTOR shall provide and maintain all traffic control devices necessary to secure their work area in accordance with the latest Manual on Uniform Traffic Control Devices (MUTCD). The OWNER may order additional safety measures if insufficient safety devices are being employed. In such instances, the CONTRACTOR shall erect in place said safety devices immediately. ***The cost of all traffic controls shall be included in the PRICES stated in the BID FORM.***

© 2019 VHB Inc,
All Rights Reserved

ARTICLE 23. MATERIAL STORAGE AND DISPOSAL

23.1 The OWNER cannot provide a material storage location or a laydown area for the CONTRACTOR. No stockpiling of construction material shall be allowed within the project limits.

23.2 The CONTRACTOR, at no additional cost to the OWNER, shall legally dispose of all material that has been removed from the project, if applicable.

GREGORY FEDERSPIEL
TOWN ADMINISTRATOR
TOWN OF MANCHESTER BY THE SEA, MA

BID FORMS

TOWN OF MANCHESTER BY THE SEA, MASSACHUSETTS
DOWNTOWN IMPROVEMENT PROJECT
PHASE II INTERSECTIONS

BID FORM

The undersigned declares that the only persons or parties interested in this Bid as principals are as stated; that the Bid is made without any collusion with other persons, firms, or corporations; that he has carefully examined all the Contract Documents as prepared by Vanasse Hangen Brustlin, Inc., 101 Walnut Street, Watertown, Massachusetts 02472 and dated April 24, 2019 that he has informed himself/herself fully in regard to all conditions pertaining to the Work and the place where it is to be done, and from them the undersigned makes this Bid. These prices shall cover all expenses incurred in performing the Work required under the Contract Documents, of which this Bid Form is a part.

If a Notice of Award accompanied by at least six unsigned copies of the Agreement and all other applicable Contract Documents is delivered to the undersigned within thirty (30) days, excluding Saturdays, Sundays, and legal holidays, after the actual date of the opening of the Bids, the undersigned will within five days, excluding Saturdays, Sundays, and legal holidays, after the date of receipt of such notification, execute and return all copies of the Agreement and all other applicable Contract Documents to OWNER. The premiums for all Bonds required shall be paid by CONTRACTOR and shall be included in the Contract Price. The undersigned further agrees that the Bid Security accompanying this Bid shall become the property of OWNER if the Bidder fails to execute the Agreement as stated above.

The Bid Security of 5% of the bid shall be sealed in a separate envelope from the Bid and then attached to the envelope containing the Bid.

The undersigned hereby agrees that the Contract Time shall commence ten (10) days following the effective date of the Agreement and to fully complete the Work within 60 Calendar Days, and in accordance with the terms as stated in the Agreement. The undersigned further agrees to pay OWNER, as liquidated damages, \$1000.00 per day for each calendar day beyond the Contract Time Limit or extension thereof that the Work remains incomplete, in accordance with the terms of the Agreement.

The undersigned acknowledges receipt of addenda numbered:

In accordance with the above understanding, the undersigned proposes to perform the Work, furnish all materials and complete the Work in its entirety in the manner and under the conditions required at the prices listed as follows:

TOWN OF MANCHESTER BY THE SEA, MASSACHUSETTS
DOWNTOWN IMPROVEMENT PROJECT
PHASE II INTERSECTIONS

SUPPLEMENTAL FORM FOR BID – BASE BID

Item No.	Quantity	Item with Unit Bid Price Written in Words	Unit Price		Amount	
			Dollars	Cents	Dollars	Cents
102.51	3	INDIVIDUAL TREE PROTECTION at _____ PER EACH				
120.1	70	UNCLASSIFIED EXCAVATION at _____ PER CUBIC YARD				
141.1	5	TEST PIT FOR EXPLORATION at _____ PER CUBIC YARD				
151.	90	GRAVEL BORROW at _____ PER CUBIC YARD				
170.	320	FINE GRADING AND COMPACTING at _____ PER SQUARE YARD				
358.	2	GATE BOX ADJUSTED at _____ PER EACH				
415.	790	PAVEMENT MICROMILLING at _____ PER SQUARE YARD				
450.22	70	SUPERPAVE SURFACE COURSE - 9.5 (SSC - 9.5) at _____ PER TON				
451.	10	HMA FOR PATCHING at _____ PER TON				
452.	70	ASPHALT EMULSION FOR TACK COAT at _____ PER GALLON				

Carried Forward



TOWN OF MANCHESTER BY THE SEA, MASSACHUSETTS
DOWNTOWN IMPROVEMENT PROJECT
PHASE II INTERSECTIONS

SUPPLEMENTAL FORM FOR BID – BASE BID

Item No.	Quantity	Item with Unit Bid Price Written in Words	Unit Price		Amount	
			Dollars	Cents	Dollars	Cents
453.	710	HMA JOINT SEALANT at _____ PER FOOT				
504.	50	GRANITE CURB TYPE VA4 - STRAIGHT at _____ PER FOOT				
504.1	60	GRANITE CURB TYPE VA4 - CURVED at _____ PER FOOT				
509.	45	GRANITE TRANSITION CURB FOR WHEELCHAIR RAMPS - STRAIGHT at _____ PER FOOT				
509.1	75	GRANITE TRANSITION CURB FOR WHEELCHAIR RAMPS - CURVED at _____ PER FOOT				
516.	3	GRANITE CURB CORNER TYPE A at _____ PER EACH				
580.	125	CURB REMOVED AND RESET at _____ PER FOOT				
590.	15	CURB REMOVED AND STACKED at _____ PER FOOT				
594.	15	CURB REMOVED AND DISCARDED at _____ PER FOOT				

Carried Forward



TOWN OF MANCHESTER BY THE SEA, MASSACHUSETTS
DOWNTOWN IMPROVEMENT PROJECT
PHASE II INTERSECTIONS

SUPPLEMENTAL FORM FOR BID – BASE BID

Item No.	Quantity	Item with Unit Bid Price Written in Words	Unit Price		Amount	
			Dollars	Cents	Dollars	Cents
697.1	2	SILT SACK at _____ PER EACH				
701.2	110	CEMENT CONCRETE WHEELCHAIR RAMP at _____ PER SQUARE YARD				
702.	30	HOT MIX ASPHALT WALK SURFACE at _____ PER TON				
703.	5	HOT MIX ASPHALT DRIVEWAY at _____ PER TON				
748.	1	MOBILIZATION at _____ PER LUMP SUM				
751.	7	LOAM BORROW at _____ PER CUBIC YARD				
765.	50	SEEDING at _____ PER SQUARE YARD				
811.36	1	ELECTRIC MANHOLE ADJUSTED at _____ PER EACH				

Carried Forward

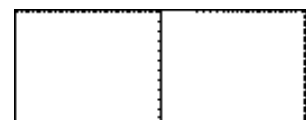

TOWN OF MANCHESTER BY THE SEA, MASSACHUSETTS
DOWNTOWN IMPROVEMENT PROJECT
PHASE II INTERSECTIONS

SUPPLEMENTAL FORM FOR BID – BASE BID

Item No.	Quantity	Item with Unit Bid Price Written in Words	Unit Price		Amount	
			Dollars	Cents	Dollars	Cents
832.	50	WARNING-REGULATORY AND ROUTE MARKER - ALUM. PANEL (TYPE A) at _____ PER SQUARE FOOT				
847.1	10	SIGN SUP (N/GUIDE)+RTE MKR W/1 BRKWAY POST ASSEMBLY - STEEL at _____ PER EACH				
850.	1	TEMPORARY TRAFFIC CONTROL at _____ PER LUMP SUM				
866.106	150	6 INCH REFLECTORIZED WHITE LINE (THERMOPLASTIC) at _____ PER FOOT				
866.112	450	12 INCH REFLECTORIZED WHITE LINE (THERMOPLASTIC) at _____ PER FOOT				
867.106	300	6 INCH REFLECTORIZED YELLOW LINE (THERMOPLASTIC) at _____ PER FOOT				
874.	1	STREET NAME SIGN at _____ PER EACH				
874.1	2	STREET SIGN REMOVED AND RESET at _____ PER EACH				

Carried Forward

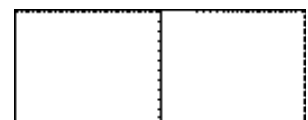

TOWN OF MANCHESTER BY THE SEA, MASSACHUSETTS
DOWNTOWN IMPROVEMENT PROJECT
PHASE II INTERSECTIONS

SUPPLEMENTAL FORM FOR BID – BASE BID

Item No.	Quantity	Item with Unit Bid Price Written in Words	Unit Price		Amount	
			Dollars	Cents	Dollars	Cents
874.2	1	TRAFFIC SIGN REMOVED AND RESET at _____ PER EACH				
874.7	2	MISCELLANEOUS SIGNS REMOVED AND STACKED at _____ PER EACH				

TOTAL BASE BID:

--	--

TOWN OF MANCHESTER BY THE SEA, MASSACHUSETTS
DOWNTOWN IMPROVEMENT PROJECT
PHASE II INTERSECTIONS

SUPPLEMENTAL FORM FOR BID – **ADD ALTERNATE No. 1**

Item No.	Quantity	Item with Unit Bid Price Written in Words	Unit Price		Amount	
			Dollars	Cents	Dollars	Cents
102.51	1	INDIVIDUAL TREE PROTECTION at _____ PER EACH				
120.1	120	UNCLASSIFIED EXCAVATION at _____ PER CUBIC YARD				
141.1	15	TEST PIT FOR EXPLORATION at _____ PER CUBIC YARD				
151.	130	GRAVEL BORROW at _____ PER CUBIC YARD				
170.	420	FINE GRADING AND COMPACTING at _____ PER SQUARE YARD				
204.	1	GUTTER INLET at _____ PER EACH				
220.	3	DRAINAGE STRUCTURE ADJUSTED at _____ PER EACH				
222.3	4	FRAME AND GRATE (OR COVER) MUNICIPAL STANDARD at _____ PER EACH				
223.1	3	FRAME AND GRATE (OR COVER) REMOVED AND STACKED at _____ PER EACH				
238.10	10	10 INCH DUCTILE IRON PIPE at _____ PER FOOT				

Carried Forward



TOWN OF MANCHESTER BY THE SEA, MASSACHUSETTS
DOWNTOWN IMPROVEMENT PROJECT
PHASE II INTERSECTIONS

SUPPLEMENTAL FORM FOR BID – **ADD ALTERNATE No. 1**

Item No.	Quantity	Item with Unit Bid Price Written in Words	Unit Price		Amount	
			Dollars	Cents	Dollars	Cents
358.	7	GATE BOX ADJUSTED at _____ PER EACH				
381.3	2	SERVICE BOX ADJUSTED at _____ PER EACH				
415.	930	PAVEMENT MICROMILLING at _____ PER SQUARE YARD				
450.22	90	SUPERPAVE SURFACE COURSE - 9.5 (SSC - 9.5) at _____ PER TON				
451.	10	HMA FOR PATCHING at _____ PER TON				
452.	80	ASPHALT EMULSION FOR TACK COAT at _____ PER GALLON				
453.	730	HMA JOINT SEALANT at _____ PER FOOT				
504.	20	GRANITE CURB TYPE VA4 - STRAIGHT at _____ PER FOOT				
504.1	65	GRANITE CURB TYPE VA4 - CURVED at _____ PER FOOT				

Carried Forward



TOWN OF MANCHESTER BY THE SEA, MASSACHUSETTS
DOWNTOWN IMPROVEMENT PROJECT
PHASE II INTERSECTIONS

SUPPLEMENTAL FORM FOR BID – **ADD ALTERNATE No. 1**

Item No.	Quantity	Item with Unit Bid Price Written in Words	Unit Price		Amount	
			Dollars	Cents	Dollars	Cents
509.	30	GRANITE TRANSITION CURB FOR WHEELCHAIR RAMPS - STRAIGHT at _____ PER FOOT				
509.1	55	GRANITE TRANSITION CURB FOR WHEELCHAIR RAMPS - CURVED at _____ PER FOOT				
514.	1	GRANITE CURB INLET - STRAIGHT at _____ PER EACH				
515.	1	GRANITE CURB INLET - CURVED at _____ PER EACH				
580.	185	CURB REMOVED AND RESET at _____ PER FOOT				
590.	25	CURB REMOVED AND STACKED at _____ PER FOOT				
594.	25	CURB REMOVED AND DISCARDED at _____ PER FOOT				
697.1	6	SILT SACK at _____ PER EACH				
701.2	80	CEMENT CONCRETE WHEELCHAIR RAMP at _____ PER SQUARE YARD				

Carried Forward

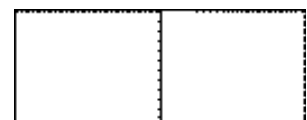

TOWN OF MANCHESTER BY THE SEA, MASSACHUSETTS
DOWNTOWN IMPROVEMENT PROJECT
PHASE II INTERSECTIONS

SUPPLEMENTAL FORM FOR BID – **ADD ALTERNATE No. 1**

Item No.	Quantity	Item with Unit Bid Price Written in Words	Unit Price		Amount	
			Dollars	Cents	Dollars	Cents
702.	60	HOT MIX ASPHALT WALK SURFACE at _____ PER TON				
703.	4	HOT MIX ASPHALT DRIVEWAY at _____ PER TON				
751.	2	LOAM BORROW at _____ PER CUBIC YARD				
765.	7	SEEDING at _____ PER SQUARE YARD				
811.36	1	ELECTRIC MANHOLE ADJUSTED at _____ PER EACH				
832.	50	WARNING-REGULATORY AND ROUTE MARKER - ALUM. PANEL (TYPE A) at _____ PER SQUARE FOOT				
847.1	15	SIGN SUP (N/GUIDE)+RTE MKR W/1 BRKWAY POST ASSEMBLY - STEEL at _____ PER EACH				
864.04	20	PAVEMENT ARROWS AND LEGENDS REFL. WHITE (THERMOPLASTIC) at _____ PER SQUARE FOOT				

Carried Forward



TOWN OF MANCHESTER BY THE SEA, MASSACHUSETTS
DOWNTOWN IMPROVEMENT PROJECT
PHASE II INTERSECTIONS

SUPPLEMENTAL FORM FOR BID – **ADD ALTERNATE No. 1**

Item No.	Quantity	Item with Unit Bid Price Written in Words	Unit Price		Amount	
			Dollars	Cents	Dollars	Cents
866.106	150	6 INCH REFLECTORIZED WHITE LINE (THERMOPLASTIC) at _____ PER FOOT				
866.112	450	12 INCH REFLECTORIZED WHITE LINE (THERMOPLASTIC) at _____ PER FOOT				
867.106	500	6 INCH REFLECTORIZED YELLOW LINE (THERMOPLASTIC) at _____ PER FOOT				
874.	1	STREET NAME SIGN at _____ PER EACH				
874.1	3	STREET SIGN REMOVED AND RESET at _____ PER EACH				
874.2	2	TRAFFIC SIGN REMOVED AND RESET at _____ PER EACH				
874.7	5	MISCELLANEOUS SIGNS REMOVED AND STACKED at _____ PER EACH				

ADD ALTERNATE No. 1 TOTAL:

--	--

TOWN OF MANCHESTER BY THE SEA, MASSACHUSETTS
DOWNTOWN IMPROVEMENT PROJECT
PHASE II INTERSECTIONS

SUPPLEMENTAL FORM FOR BID – **ADD ALTERNATE No. 2**

Item No.	Quantity	Item with Unit Bid Price Written in Words	Unit Price		Amount	
			Dollars	Cents	Dollars	Cents
102.51	2	INDIVIDUAL TREE PROTECTION at _____ PER EACH				
120.1	40	UNCLASSIFIED EXCAVATION at _____ PER CUBIC YARD				
141.1	5	TEST PIT FOR EXPLORATION at _____ PER CUBIC YARD				
151.	70	GRAVEL BORROW at _____ PER CUBIC YARD				
170.	200	FINE GRADING AND COMPACTING at _____ PER SQUARE YARD				
220.	2	DRAINAGE STRUCTURE ADJUSTED at _____ PER EACH				
222.3	2	FRAME AND GRATE (OR COVER) MUNICIPAL STANDARD at _____ PER EACH				
223.1	2	FRAME AND GRATE (OR COVER) REMOVED AND STACKED at _____ PER EACH				
358.	2	GATE BOX ADJUSTED at _____ PER EACH				
381.3	4	SERVICE BOX ADJUSTED at _____ PER EACH				

Carried Forward



TOWN OF MANCHESTER BY THE SEA, MASSACHUSETTS
DOWNTOWN IMPROVEMENT PROJECT
PHASE II INTERSECTIONS

SUPPLEMENTAL FORM FOR BID – **ADD ALTERNATE No. 2**

Item No.	Quantity	Item with Unit Bid Price Written in Words	Unit Price		Amount	
			Dollars	Cents	Dollars	Cents
415.	680	PAVEMENT MICROMILLING at _____ PER SQUARE YARD				
450.22	80	SUPERPAVE SURFACE COURSE - 9.5 (SSC - 9.5) at _____ PER TON				
451.	10	HMA FOR PATCHING at _____ PER TON				
452.	110	ASPHALT EMULSION FOR TACK COAT at _____ PER GALLON				
453.	590	HMA JOINT SEALANT at _____ PER FOOT				
504.	10	GRANITE CURB TYPE VA4 - STRAIGHT at _____ PER FOOT				
504.1	45	GRANITE CURB TYPE VA4 - CURVED at _____ PER FOOT				
509.	25	GRANITE TRANSITION CURB FOR WHEELCHAIR RAMPS - STRAIGHT at _____ PER FOOT				
509.1	65	GRANITE TRANSITION CURB FOR WHEELCHAIR RAMPS - CURVED at _____ PER FOOT				

Carried Forward



TOWN OF MANCHESTER BY THE SEA, MASSACHUSETTS
DOWNTOWN IMPROVEMENT PROJECT
PHASE II INTERSECTIONS

SUPPLEMENTAL FORM FOR BID – **ADD ALTERNATE No. 2**

Item No.	Quantity	Item with Unit Bid Price Written in Words	Unit Price		Amount	
			Dollars	Cents	Dollars	Cents
580.	145	CURB REMOVED AND RESET at _____ PER FOOT				
590.	20	CURB REMOVED AND STACKED at _____ PER FOOT				
594.	20	CURB REMOVED AND DISCARDED at _____ PER FOOT				
697.1	4	SILT SACK at _____ PER EACH				
701.2	80	CEMENT CONCRETE WHEELCHAIR RAMP at _____ PER SQUARE YARD				
702.	20	HOT MIX ASPHALT WALK SURFACE at _____ PER TON				
711.	2	BOUND REMOVED AND RESET at _____ PER EACH				
751.	2	LOAM BORROW at _____ PER CUBIC YARD				

Carried Forward

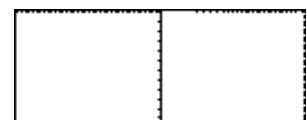

TOWN OF MANCHESTER BY THE SEA, MASSACHUSETTS
DOWNTOWN IMPROVEMENT PROJECT
PHASE II INTERSECTIONS

SUPPLEMENTAL FORM FOR BID – **ADD ALTERNATE No. 2**

Item No.	Quantity	Item with Unit Bid Price Written in Words	Unit Price		Amount	
			Dollars	Cents	Dollars	Cents
765.	10	SEEDING at _____ PER SQUARE YARD				
811.36	1	ELECTRIC MANHOLE ADJUSTED at _____ PER EACH				
832.	70	WARNING-REGULATORY AND ROUTE MARKER - ALUM. PANEL (TYPE A) at _____ PER SQUARE FOOT				
847.1	15	SIGN SUP (N/GUIDE)+RTE MKR W/1 BRKWAY POST ASSEMBLY - STEEL at _____ PER EACH				
866.106	100	6 INCH REFLECTORIZED WHITE LINE (THERMOPLASTIC) at _____ PER FOOT				
866.112	300	12 INCH REFLECTORIZED WHITE LINE (THERMOPLASTIC) at _____ PER FOOT				
867.106	200	6 INCH REFLECTORIZED YELLOW LINE (THERMOPLASTIC) at _____ PER FOOT				

Carried Forward

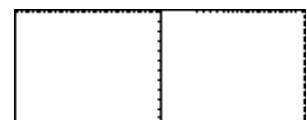

TOWN OF MANCHESTER BY THE SEA, MASSACHUSETTS
DOWNTOWN IMPROVEMENT PROJECT
PHASE II INTERSECTIONS

SUPPLEMENTAL FORM FOR BID – **ADD ALTERNATE No. 2**

Item No.	Quantity	Item with Unit Bid Price Written in Words	Unit Price		Amount	
			Dollars	Cents	Dollars	Cents
874.2	7	TRAFFIC SIGN REMOVED AND RESET at _____ PER EACH				
874.7	2	MISCELLANEOUS SIGNS REMOVED AND STACKED at _____ PER EACH				

ADD ALTERNATE No. 2 TOTAL:

--	--

BASE BID TOTAL:

--	--

ADD ALTERNATE No. 1 TOTAL:

--	--

ADD ALTERNATE No. 2 TOTAL:

--	--

**TOTAL BID WITH
ADD ALTERNATE No. 1
AND ADD ALTERNATE No. 2**

--	--

The undersigned declares he understands that the quantities shown are approximate only and are subject to either increase or decrease and that should the quantities of any of the items of work be increased, the undersigned proposes to do the additional work at the unit prices set forth herein, and should the quantities be decreased, undersigned also understands that payment will be made on actual quantities installed at the unit bid price, and the undersigned will make no claims for anticipated profits for any decrease in the quantities. Actual quantities will be determined upon completion of the job.

The undersigned agrees that extra work, if any, will be performed in accordance with Article 10 of the Conditions of the Contract and will be paid for in accordance with Article 11 of the Conditions of the Contract.

Amounts shall be shown in both words and figures, where indicated. In case of discrepancy, the amount shown in words will govern.

The above price shall include all labor, materials, bailing, shoring, removal, overhead, profit, insurance and incidentals required to complete the Work.

The bidding and award of this Contract will be in accordance with the provisions of M.G.L., Chapter 30, Section 39M.

The names and residences of all persons and parties interested in the foregoing Bid as principals are as follows:

(Give first and last names in full. In the case of a corporation, see Article 8.3 of the Instructions to Bidders, in the case of a partnership, see Article 8.4 of the Instructions to Bidders.)

Pursuant to M.G.L. Chapter 62C, Section 49A, I certify under the pains and penalties of perjury that _____ has complied with all federal laws, filed all state tax returns, paid all state taxes, properly reported all employees and contractors, and withheld and remitted all required child support.

The undersigned hereby certifies that he is able to furnish labor that can work in harmony with all other elements of labor employed or to be employed on the work.

The undersigned hereby certifies under the penalties of perjury that this bid is in all respects bona fide, fair and made without collusion or fraud with any other person. As used in this section, the word "person" shall mean any natural person, joint venture, partnership, corporation, or other business or legal entity. The undersigned further certifies under penalty of perjury that the said undersigned is not presently debarred from doing public construction work in the Commonwealth under the provisions of Section Twenty-nine F of Chapter Twenty-nine, or any other applicable debarment provisions of any other chapter of the General Laws or any rule or requisition promulgated hereunder.

Social Security Number or
Federal Identification Number

Signature of Individual or Corporate Name

By: _____
Corporate Officer (if applicable)

Notice of acceptance should be mailed, telegraphed, or delivered to the undersigned Bidder at the following address following:

(Name)

By: _____
(Title)

(Business Address)

(City and State)

Date _____

Note: If the Bidder is a corporation, indicate State of incorporation under signature, and affix corporate seal; if a partnership, give full names and residential addresses, if different from business address.

BID BOND

**PROJECT: Downtown Improvement Project
 Phase II Intersections
 Manchester by the Sea, Massachusetts**

KNOW ALL MEN BY THESE PRESENTS, that we the undersigned

as PRINCIPAL, AND _____
and SURETY, are held and firmly bound unto the Town of Manchester by the Sea,
Massachusetts, hereinafter called the OWNER in the penal sum of
_____ Dollars (\$ _____),
lawful money of the United States, for the payment of which sum well and truly to be made, we
bind ourselves, our heirs, executors, successors, and assigns, jointly and severally, firmly by these
presents.

THE CONDITION OF THIS OBLIGATION IS SUCH, that whereas the Principal has submitted
the accompanying bid, dated _____, 2019, for _____
(total Base Bid plus all Add Alternate Bids).

NOW THEREFORE, if the Principal shall not withdraw said bids within the period specified
therein after the opening of the same, or, if no period be specified, within sixty (60) days after the
said opening, and shall within the period specified therefore, or if no period be specified, within
ten (10) days after the prescribed forms are presented to him for signature, enter into a written
Contract with the OWNER in accordance with the Bid as accepted and give bond with good and
sufficient surety or sureties, as may be required for the faithful performance and proper
fulfillment of such Contract; or in the event of the withdrawal of said Bid within the period
specified, or the failure to enter into such Contract and give such bond within the time specified,
if the Principal shall pay the OWNER the difference between the amount specified in said Bid
and the amount for which the OWNER may procure The required work or supplies for both, if the
latter be in excess of the former, then the above obligation shall be void and of no effect,
otherwise to remain in full force and virtue.

IN WITNESS WHEREOF, the above-bonded parties have executed this instrument under their
several seals this _____ day of _____, 2019, the name and corporate seal of
each corporate party being hereto affixed and these presents duly signed by its undersigned
representative, pursuant to authority of its governing body.

In presence of:

_____ (SEAL)
(Individual Principal)

Business Address _____

Partnership _____ (SEAL)

Business Address _____

Attest: By _____ (Corp. Principal)

Business Address _____

By _____ (Affix Corp. Seal)

Attest:

By _____ (Corp. Surety)

Countersigned

By _____
Attorney-in-Fact,
State of _____

CERTIFICATE AS TO CORPORATE PRINCIPAL

I, _____, certify that I am the

Secretary of the Corporation named as Principal within the bond; that

_____, who signed and said bond on behalf of the Principal was then _____ of said corporation; and that I know his signature, and his signature thereto is genuine; and that said bond was duly signed, sealed and attested to for and in behalf of said corporation by authority of this governing body.

_____ (Corporate Seal)

Title _____

CONTRACT FORMS

TOWN OF MANCHESTER BY THE SEA, MASSACHUSETTS
DOWNTOWN IMPROVEMENT PROJECT
PHASE II INTERSECTIONS

AGREEMENT

THIS AGREEMENT made as of the _____ day of _____ in the year 2019 by and between the Town of Manchester by the Sea, Massachusetts acting through its Town Administrator hereinafter called OWNER and _____ with legal address _____ and _____ principal place of business at _____ hereinafter called CONTRACTOR. OWNER and CONTRACTOR in consideration of the mutual covenants hereinafter set forth, agree as follows:

ARTICLE 1. WORK

1.1 CONTRACTOR shall perform the Work as specified or indicated in the Contract Documents. The Work is as described in the Special Provisions on page SP-1.

ARTICLE 2. ENGINEER

2.1 The Project has been designed by Vanasse Hangen Brustlin, Inc., 101 Walnut Street, Watertown, Massachusetts 02472 who will act as ENGINEER in connection with completion of the Work in accordance with the Contract Documents.

ARTICLE 3. CONTRACT TIME

3.1 Contract Time shall commence ten (10) days following the Effective Date of this Agreement. Contract duration shall be 60 calendar days, with all activities necessary to fully complete the Work executed within that time in accordance with the agreement

3.2 CONTRACTOR agrees that the Work shall be prosecuted regularly, diligently and uninterruptedly and at such rate of progress as will insure full completion thereof within the Contract Time stated above. It is expressly understood and agreed, by and between CONTRACTOR and OWNER that the Contract Time is reasonable for the completion of the Work, taking into consideration the average climatic range and usual industrial conditions prevailing in this locality.

ARTICLE 4. CONTRACT PRICE

4.1 OWNER will pay CONTRACTOR for performance of the Work in accordance with the Contract Documents in current funds at the unit prices agreed upon in the CONTRACTOR's Bid Form attached to this Agreement.

ARTICLE 5. APPLICATIONS FOR PAYMENT

5.1 CONTRACTOR shall submit Applications for Payment in accordance with Article 14 of the Conditions of the Contract. Applications for Payment will be processed by ENGINEER as provided in the _____ Conditions _____ of _____ the _____ Contract.

ARTICLE 6. PROGRESS AND FINAL PAYMENTS

6.1 OWNER will make progress payments on account of the Contract Price on the basis of CONTRACTOR's Applications for Payment as recommended by ENGINEER, monthly during construction as provided below.

All progress payments will be on the basis of the progress of the Work measured by the schedule of values provided for in Paragraph 14.01 of the Conditions of the Contract.

6.2 OWNER will make progress and final payments as provided in Article 14 of the Conditions of the Contract and in accordance with the applicable Massachusetts General Law.

ARTICLE 7. LIQUIDATED DAMAGES

7.1 OWNER and CONTRACTOR recognize that time is of the essence of this Agreement and that OWNER will suffer financial loss if the Work is not completed within the Contract Time specified in Article 3 above, plus any extensions thereof allowed in accordance with Article 12 of the General Conditions. They also recognize the delays, expense and difficulties involved in proving, in a legal or arbitration proceeding, the actual loss suffered by OWNER if the Work is not completed on time. Accordingly, instead of requiring any such proof OWNER and CONTRACTOR agree that as liquidated damages for delay (but not as a penalty) CONTRACTOR shall pay OWNER \$1000.00 per day for each calendar day of delay until the Work is complete.

7.2 Provided, that CONTRACTOR shall not be charged with liquidated damages or any excess cost when the delay in completion of the Work is for reasons included in Paragraph 12.03 of the General Conditions.

7.3 Provided, further, that CONTRACTOR shall, furnish OWNER the required notification of such delays in accordance with Paragraph 12.02 of the General Conditions.

ARTICLE 8. ASSURANCE

8.1 CONTRACTOR has familiarized himself/herself with the nature and extent of the Contract Documents, Work, locality, and with all local conditions and Federal, State and local laws, ordinances, rules and regulations that in any manner may affect cost, progress or performance of the Work.

8.2 CONTRACTOR has studied carefully all reports of investigations and tests of subsurface and latent physical conditions at the site or otherwise affecting cost, progress or performance of the Work which were relied upon by ENGINEER in the preparation of the Drawings and Specifications and which have been identified in Article 4 of the Supplementary Conditions.

8.3 CONTRACTOR has made or caused to be made examinations, investigations and tests and studies of such reports and related data in addition to those referred to in the above paragraph as he deems necessary for the performance of the Work at the Contract Price within the Contract Time and in accordance with the other terms and conditions of the Contract Documents; and no additional examinations, investigations, tests, reports or similar data are or will be required by him for such purposes.

8.4 CONTRACTOR has correlated the results of all such observations, examinations, investigations, tests, reports and data with the terms and conditions of the Contract Documents.

8.5 CONTRACTOR has given ENGINEER written notice of any conflict, error or discrepancy that he/she has discovered in the Contract Documents and the written resolution thereof by ENGINEER is acceptable to CONTRACTOR.

8.6 CONTRACTOR agrees that the Contract Documents are sufficient in scope and detail to indicate and convey understanding of all terms and conditions for performance of the Work.

ARTICLE 9. CONTRACT DOCUMENTS

9.1 The Contract Documents which comprise the Contract between OWNER and CONTRACTOR are attached hereto and made a part hereof and consist of the following:

9.1.1 Invitation to Bid.

9.1.2 Instructions for Bidders.

9.1.3 Bid Form.

9.1.4 This Agreement.

9.1.5 Performance Bond, EJCDC Document C-610, 2010 edition, Payment Bond, EJCDC Document C-615, 2010 edition, and other required Bonds.

9.1.6 General Conditions, EJCDC Document C-700, 2007 edition.

9.1.7 Supplementary Conditions Parts I and II.

9.1.8 Special Provisions (as listed in Table of Contents).

9.1.9 Plans, numbered 1 through 20, inclusive, dated April 24, 2019.

9.1.10 Addenda numbers _____ to _____, inclusive.

9.1.11 Any modification, including Change Orders, duly delivered after execution of Agreement.

ARTICLE 10. MISCELLANEOUS

10.1 Terms used in this Agreement, which are defined in Article 1 of the Conditions of the Contract shall have the meanings assigned in the Conditions of the Contract.

10.2 Neither OWNER nor CONTRACTOR shall, without the prior written consent of the other, assign or sublet in whole or in part his interest under any of the Contract Documents; and, specifically but without limitation, CONTRACTOR shall not assign any monies due or to become due without the prior written consent of OWNER. In case CONTRACTOR assigns all or any part of any monies due or to become due under this Contract, the instrument of assignment shall contain a clause substantially to the effect that it is agreed that the right of the assignee in and to any monies due or to become due to CONTRACTOR shall be subject to prior claims of all persons, firms and corporations for services rendered or materials supplied for the performance of the Work called for in this Contract.

10.3 OWNER and CONTRACTOR each binds himself, his partners, successors, assigns and legal representatives in respect to all covenants, agreements and obligations contained in the Contract Documents.

10.4 The Contract Documents constitute the entire agreement between OWNER and CONTRACTOR and may only be altered, amended or repealed by a Modification.

10.5 This agreement shall be governed by and constructed in accordance with Massachusetts' law.

10.6 If any provisions of this Agreement are determined to be invalid or unenforceable by final judgement of a court of competent jurisdiction, the remaining provisions shall continue in effect to the extent _____ permitted _____ by _____ law.

IN WITNESS WHEREOF, the parties hereto have signed this Agreement in sextuple. Four copies each have been delivered to OWNER and one copy each to CONTRACTOR and ENGINEER. All portions of the Contract Documents have been signed or identified by OWNER and CONTRACTOR or by ENGINEER on their behalf.

This Agreement shall become effective on _____, 2019

IN WITNESS WHEREOF, the parties hereto have executed this Agreement to be effective as of the date first above written.

OWNER:

CONTRACTOR:

By: Gregory T. Federspiel
Title: Town Administrator
Date: _____

By:
Title:
Date: _____

Address for giving notices:

Address for giving notices:

Town of Manchester by the Sea
10 Central Street
Manchester by the Sea, Massachusetts 01944

(CORPORATE SEAL)

AFFIDAVIT OF COMPLIANCE WITH G.L. c.44, §31C, CERTIFICATE OF
APPROPRIATION FOR THE CONTRACT

The undersigned, Town Accountant, Town of Manchester by the Sea, hereby certifies, pursuant to G.L. c.44, §31C, that an appropriation in the amount equal to the contract price for the contract entitled: Downtown Improvement Project Phase II Intersections is available for payment for services rendered under said contract and that Gregory T. Federspiel, Town Administrator of the Town of Manchester by the Sea, has been authorized to execute said contract, approve all requisitions and change orders thereto:

Article ___ ATM _____

ACCOUNT CODE _____
FY _____

Approved as to Form Only:

Town Counsel
Town of Manchester by the Sea

Town Accountant
Town of Manchester by the Sea

Note: If CONTRACTOR is a corporation, an affidavit giving the principal the right to sign the Agreement must accompany the executed Agreement.

PERFORMANCE BOND

CONTRACTOR *(name and address)*:

SURETY *(name and address of principal place of business)*:

OWNER *(name and address)*:

CONSTRUCTION CONTRACT

Effective Date of the Agreement:

Amount:

Description *(name and location)*:

BOND

Bond Number:

Date *(not earlier than the Effective Date of the Agreement of the Construction Contract)*:

Amount:

Modifications to this Bond Form: None See Paragraph 16

Surety and Contractor, intending to be legally bound hereby, subject to the terms set forth below, do each cause this Performance Bond to be duly executed by an authorized officer, agent, or representative.

CONTRACTOR AS PRINCIPAL

SURETY

(seal)
Contractor's Name and Corporate Seal

(seal)
Surety's Name and Corporate Seal

By: _____
Signature

By: _____
Signature *(attach power of attorney)*

Print Name

Print Name

Title

Title

Attest: _____
Signature

Attest: _____
Signature

Title

Title

Notes: (1) Provide supplemental execution by any additional parties, such as joint venturers. (2) Any singular reference to Contractor, Surety, Owner, or other party shall be considered plural where applicable.

1. The Contractor and Surety, jointly and severally, bind themselves, their heirs, executors, administrators, successors, and assigns to the Owner for the performance of the Construction Contract, which is incorporated herein by reference.

2. If the Contractor performs the Construction Contract, the Surety and the Contractor shall have no obligation under this Bond, except when applicable to participate in a conference as provided in Paragraph 3.

3. If there is no Owner Default under the Construction Contract, the Surety's obligation under this Bond shall arise after:

3.1 The Owner first provides notice to the Contractor and the Surety that the Owner is considering declaring a Contractor Default. Such notice shall indicate whether the Owner is requesting a conference among the Owner, Contractor, and Surety to discuss the Contractor's performance. If the Owner does not request a conference, the Surety may, within five (5) business days after receipt of the Owner's notice, request such a conference. If the Surety timely requests a conference, the Owner shall attend. Unless the Owner agrees otherwise, any conference requested under this Paragraph 3.1 shall be held within ten (10) business days of the Surety's receipt of the Owner's notice. If the Owner, the Contractor, and the Surety agree, the Contractor shall be allowed a reasonable time to perform the Construction Contract, but such an agreement shall not waive the Owner's right, if any, subsequently to declare a Contractor Default;

3.2 The Owner declares a Contractor Default, terminates the Construction Contract and notifies the Surety; and

3.3 The Owner has agreed to pay the Balance of the Contract Price in accordance with the terms of the Construction Contract to the Surety or to a contractor selected to perform the Construction Contract.

4. Failure on the part of the Owner to comply with the notice requirement in Paragraph 3.1 shall not constitute a failure to comply with a condition precedent to the Surety's obligations, or release the Surety from its obligations, except to the extent the Surety demonstrates actual prejudice.

5. When the Owner has satisfied the conditions of Paragraph 3, the Surety shall promptly and at the Surety's expense take one of the following actions:

5.1 Arrange for the Contractor, with the consent of the Owner, to perform and complete the Construction Contract;

5.2 Undertake to perform and complete the Construction Contract itself, through its agents or independent contractors;

5.3 Obtain bids or negotiated proposals from qualified contractors acceptable to the Owner for a contract for performance and completion of the Construction Contract, arrange for a contract to be prepared for execution by the Owner and a contractor selected with the Owners concurrence, to be secured with performance and payment bonds executed by a qualified surety equivalent to the bonds issued on the Construction Contract, and pay to the Owner the amount of damages as described in Paragraph 7 in excess of the Balance of the Contract Price incurred by the Owner as a result of the Contractor Default; or

5.4 Waive its right to perform and complete, arrange for completion, or obtain a new contractor, and with reasonable promptness under the circumstances:

5.4.1 After investigation, determine the amount for which it may be liable to the Owner and, as soon as practicable after the amount is determined, make payment to the Owner; or

5.4.2 Deny liability in whole or in part and notify the Owner, citing the reasons for denial.

6. If the Surety does not proceed as provided in Paragraph 5 with reasonable promptness, the Surety shall be deemed to be in default on this Bond seven days after receipt of an additional written notice from the Owner to the Surety demanding that the Surety perform its obligations under this Bond, and the Owner shall be entitled to enforce any remedy available to the Owner. If the Surety proceeds as provided in Paragraph 5.4, and the Owner refuses the payment or the Surety has denied liability, in whole or in part, without further notice the Owner shall be entitled to enforce any remedy available to the Owner.

7. If the Surety elects to act under Paragraph 5.1, 5.2, or 5.3, then the responsibilities of the Surety to the Owner shall not be greater than those of the Contractor under the Construction Contract, and the responsibilities of the Owner to the Surety shall not be greater than those of the Owner under the Construction Contract. Subject to the commitment by the Owner to pay the Balance of the Contract Price, the Surety is obligated, without duplication for:

7.1 the responsibilities of the Contractor for correction of defective work and completion of the Construction Contract;

7.2 additional legal, design professional, and delay costs resulting from the Contractor's Default, and resulting from the actions or failure to act of the Surety under Paragraph 5; and

7.3 liquidated damages, or if no liquidated damages are specified in the Construction Contract, actual damages caused by delayed performance or non-performance of the Contractor.

8. If the Surety elects to act under Paragraph 5.1, 5.3, or 5.4, the Surety's liability is limited to the amount of this Bond.

9. The Surety shall not be liable to the Owner or others for obligations of the Contractor that are unrelated to the Construction Contract, and the Balance of the Contract Price shall not be reduced or set off on account of any such unrelated obligations. No right of action shall accrue on this Bond to any person or entity other than the Owner or its heirs, executors, administrators, successors, and assigns.

10. The Surety hereby waives notice of any change, including changes of time, to the Construction Contract or to related subcontracts, purchase orders, and other obligations.

11. Any proceeding, legal or equitable, under this Bond may be instituted in any court of competent jurisdiction in the location in which the work or part of the work is located and shall be instituted within two years after a declaration of Contractor Default or within two years after the Contractor ceased working or within two years after the Surety refuses or fails to perform its obligations under this Bond, whichever occurs first. If the provisions of this paragraph are void or prohibited by law, the minimum periods of limitations

available to sureties as a defense in the jurisdiction of the suit shall be applicable.

12. Notice to the Surety, the Owner, or the Contractor shall be mailed or delivered to the address shown on the page on which their signature appears.

13. When this Bond has been furnished to comply with a statutory or other legal requirement in the location where the construction was to be performed, any provision in this Bond conflicting with said statutory or legal requirement shall be deemed deleted herefrom and provisions conforming to such statutory or other legal requirement shall be deemed incorporated herein. When so furnished, the intent is that this Bond shall be construed as a statutory bond and not as a common law bond.

14. Definitions

14.1 Balance of the Contract Price: The total amount payable by the Owner to the Contractor under the Construction Contract after all proper adjustments have been made including allowance for the Contractor for any amounts received or to be received by the Owner in settlement of insurance or other claims for damages to which the Contractor is entitled, reduced by all valid and proper payments made to or on behalf of the Contractor under the Construction Contract.

14.2 Construction Contract: The agreement between the Owner and Contractor identified on the cover page, including all

Contract Documents and changes made to the agreement and the Contract Documents.

14.3 Contractor Default: Failure of the Contractor, which has not been remedied or waived, to perform or otherwise to comply with a material term of the Construction Contract.

14.4 Owner Default: Failure of the Owner, which has not been remedied or waived, to pay the Contractor as required under the Construction Contract or to perform and complete or comply with the other material terms of the Construction Contract.

14.5 Contract Documents: All the documents that comprise the agreement between the Owner and Contractor.

15. If this Bond is issued for an agreement between a contractor and subcontractor, the term Contractor in this Bond shall be deemed to be Subcontractor and the term Owner shall be deemed to be Contractor.

16. Modifications to this Bond are as follows:

PAYMENT BOND

CONTRACTOR *(name and address)*:

SURETY *(name and address of principal place of business)*:

OWNER *(name and address)*:

CONSTRUCTION CONTRACT

Effective Date of the Agreement:

Amount:

Description *(name and location)*:

BOND

Bond Number:

Date *(not earlier than the Effective Date of the Agreement of the Construction Contract)*:

Amount:

Modifications to this Bond Form: None See Paragraph 18

Surety and Contractor, intending to be legally bound hereby, subject to the terms set forth below, do each cause this Payment Bond to be duly executed by an authorized officer, agent, or representative.

CONTRACTOR AS PRINCIPAL

SURETY

(seal)
Contractor's Name and Corporate Seal

(seal)
Surety's Name and Corporate Seal

By: _____
Signature

By: _____
Signature *(attach power of attorney)*

Print Name

Print Name

Title

Title

Attest: _____
Signature

Attest: _____
Signature

Title

Title

Notes: (1) Provide supplemental execution by any additional parties, such as joint venturers. (2) Any singular reference to Contractor, Surety, Owner, or other party shall be considered plural where applicable.

1. The Contractor and Surety, jointly and severally, bind themselves, their heirs, executors, administrators, successors, and assigns to the Owner to pay for labor, materials, and equipment furnished for use in the performance of the Construction Contract, which is incorporated herein by reference, subject to the following terms.
2. If the Contractor promptly makes payment of all sums due to Claimants, and defends, indemnifies, and holds harmless the Owner from claims, demands, liens, or suits by any person or entity seeking payment for labor, materials, or equipment furnished for use in the performance of the Construction Contract, then the Surety and the Contractor shall have no obligation under this Bond.
3. If there is no Owner Default under the Construction Contract, the Surety's obligation to the Owner under this Bond shall arise after the Owner has promptly notified the Contractor and the Surety (at the address described in Paragraph 13) of claims, demands, liens, or suits against the Owner or the Owner's property by any person or entity seeking payment for labor, materials, or equipment furnished for use in the performance of the Construction Contract, and tendered defense of such claims, demands, liens, or suits to the Contractor and the Surety.
4. When the Owner has satisfied the conditions in Paragraph 3, the Surety shall promptly and at the Surety's expense defend, indemnify, and hold harmless the Owner against a duly tendered claim, demand, lien, or suit.
5. The Surety's obligations to a Claimant under this Bond shall arise after the following:
 - 5.1 Claimants who do not have a direct contract with the Contractor,
 - 5.1.1 have furnished a written notice of non-payment to the Contractor, stating with substantial accuracy the amount claimed and the name of the party to whom the materials were, or equipment was, furnished or supplied or for whom the labor was done or performed, within ninety (90) days after having last performed labor or last furnished materials or equipment included in the Claim; and
 - 5.1.2 have sent a Claim to the Surety (at the address described in Paragraph 13).
 - 5.2 Claimants who are employed by or have a direct contract with the Contractor have sent a Claim to the Surety (at the address described in Paragraph 13).
6. If a notice of non-payment required by Paragraph 5.1.1 is given by the Owner to the Contractor, that is sufficient to satisfy a Claimant's obligation to furnish a written notice of non-payment under Paragraph 5.1.1.
7. When a Claimant has satisfied the conditions of Paragraph 5.1 or 5.2, whichever is applicable, the Surety shall promptly and at the Surety's expense take the following actions:
 - 7.1 Send an answer to the Claimant, with a copy to the Owner, within sixty (60) days after receipt of the Claim, stating the amounts that are undisputed and the basis for challenging any amounts that are disputed; and
 - 7.2 Pay or arrange for payment of any undisputed amounts.
 - 7.3 The Surety's failure to discharge its obligations under Paragraph 7.1 or 7.2 shall not be deemed to constitute a waiver of defenses the Surety or Contractor may have or acquire as to a Claim, except as to undisputed amounts for which the Surety and Claimant have reached agreement. If, however, the Surety fails to discharge its obligations under Paragraph 7.1 or 7.2, the Surety shall indemnify the Claimant for the reasonable attorney's fees the Claimant incurs thereafter to recover any sums found to be due and owing to the Claimant.
8. The Surety's total obligation shall not exceed the amount of this Bond, plus the amount of reasonable attorney's fees provided under Paragraph 7.3, and the amount of this Bond shall be credited for any payments made in good faith by the Surety.
9. Amounts owed by the Owner to the Contractor under the Construction Contract shall be used for the performance of the Construction Contract and to satisfy claims, if any, under any construction performance bond. By the Contractor furnishing and the Owner accepting this Bond, they agree that all funds earned by the Contractor in the performance of the Construction Contract are dedicated to satisfy obligations of the Contractor and Surety under this Bond, subject to the Owner's priority to use the funds for the completion of the work.
10. The Surety shall not be liable to the Owner, Claimants, or others for obligations of the Contractor that are unrelated to the Construction Contract. The Owner shall not be liable for the payment of any costs or expenses of any Claimant under this Bond, and shall have under this Bond no obligation to make payments to or give notice on behalf of Claimants, or otherwise have any obligations to Claimants under this Bond.
11. The Surety hereby waives notice of any change, including changes of time, to the Construction Contract or to related subcontracts, purchase orders, and other obligations.
12. No suit or action shall be commenced by a Claimant under this Bond other than in a court of competent jurisdiction in the state in which the project that is the subject of the Construction Contract is located or after the expiration of one year from the date (1) on which the Claimant sent a Claim to the Surety pursuant to Paragraph 5.1.2 or 5.2, or (2) on which the last labor or service was performed by

anyone or the last materials or equipment were furnished by anyone under the Construction Contract, whichever of (1) or (2) first occurs. If the provisions of this paragraph are void or prohibited by law, the minimum period of limitation available to sureties as a defense in the jurisdiction of the suit shall be applicable.

13. Notice and Claims to the Surety, the Owner, or the Contractor shall be mailed or delivered to the address shown on the page on which their signature appears. Actual receipt of notice or Claims, however accomplished, shall be sufficient compliance as of the date received.
14. When this Bond has been furnished to comply with a statutory or other legal requirement in the location where the construction was to be performed, any provision in this Bond conflicting with said statutory or legal requirement shall be deemed deleted herefrom and provisions conforming to such statutory or other legal requirement shall be deemed incorporated herein. When so furnished, the intent is that this Bond shall be construed as a statutory bond and not as a common law bond.
15. Upon requests by any person or entity appearing to be a potential beneficiary of this Bond, the Contractor and Owner shall promptly furnish a copy of this Bond or shall permit a copy to be made.

16. Definitions

16.1 **Claim:** A written statement by the Claimant including at a minimum:

1. The name of the Claimant;
2. The name of the person for whom the labor was done, or materials or equipment furnished;
3. A copy of the agreement or purchase order pursuant to which labor, materials, or equipment was furnished for use in the performance of the Construction Contract;
4. A brief description of the labor, materials, or equipment furnished;
5. The date on which the Claimant last performed labor or last furnished materials or equipment for use in the performance of the Construction Contract;
6. The total amount earned by the Claimant for labor, materials, or equipment furnished as of the date of the Claim;
7. The total amount of previous payments received by the Claimant; and
8. The total amount due and unpaid to the Claimant for labor, materials, or equipment furnished as of the date of the Claim.

16.2 **Claimant:** An individual or entity having a direct contract with the Contractor or with a subcontractor of the Contractor to furnish labor, materials, or equipment for use in the performance of the Construction Contract. The term Claimant also includes any individual or entity that has rightfully asserted a claim under an applicable mechanic's lien or similar statute against the real property upon which the Project is located. The intent of this Bond shall be to include without limitation in the terms of

"labor, materials, or equipment" that part of the water, gas, power, light, heat, oil, gasoline, telephone service, or rental equipment used in the Construction Contract, architectural and engineering services required for performance of the work of the Contractor and the Contractor's subcontractors, and all other items for which a mechanic's lien may be asserted in the jurisdiction where the labor, materials, or equipment were furnished.

16.3 **Construction Contract:** The agreement between the Owner and Contractor identified on the cover page, including all Contract Documents and all changes made to the agreement and the Contract Documents.

16.4 **Owner Default:** Failure of the Owner, which has not been remedied or waived, to pay the Contractor as required under the Construction Contract or to perform and complete or comply with the other material terms of the Construction Contract.

16.5 **Contract Documents:** All the documents that comprise the agreement between the Owner and Contractor.

17. If this Bond is issued for an agreement between a contractor and subcontractor, the term Contractor in this Bond shall be deemed to be Subcontractor and the term Owner shall be deemed to be Contractor.

18. Modifications to this Bond are as follows:

NOTICE OF AWARD

PROJECT IDENTIFICATION: **Downtown Improvement Project
Phase II Intersections
Manchester by the Sea, Massachusetts**

Dated _____, 2019

TO: _____

ADDRESS: _____

OWNER'S PROJECT NO. _____

PROJECT: _____

OWNER'S CONTRACT NO. _____

CONTRACT FOR Downtown Improvement Project Phase II Intersections

(Insert name of Contract as it appears in the Bidding Documents)

You are notified that your Bid, dated _____, 2019, for the above Contract has been considered. You are the apparent successful bidder and have been awarded a contract for

(Indicate total Work, Alternates or sections of Work awarded)

The Contract Price of your contract is _____ Dollars (\$ _____).

Three copies of each of the proposed Contract Documents accompany this Notice of Award.

You must comply with the following conditions precedent within fifteen days of the date of this Notice of Award, that is by _____, 2019.

1. You must deliver to the OWNER three fully executed counterparts of the Agreement including all the Contract Documents. This includes the triplicate sets of Drawings. Each of the Contract Documents must bear your signature.
2. You must deliver with the executed Agreement the Contract Security (Bonds) as specified in the General Conditions (paragraph 5.1).

NOTICE OF AWARD (CONTINUED)

3. (list other conditions precedent).

Failure to comply with these conditions within the time specified will entitle OWNER to consider your bid abandoned, to annul this Notice of Award and to declare your Bid Security forfeited.

Within ten days after you comply with those conditions, OWNER will return to you one fully signed counterpart of the Agreement with the Contract Documents attached.

(OWNER)

By _____
(AUTHORIZED SIGNATURE)

(TITLE)

Copy to ENGINEER
(Use Certified Mail,
Return Receipt Requested)

NOTICE TO PROCEED

PROJECT IDENTIFICATION: **Downtown Improvement Project
Phase II Intersections
Manchester by the Sea, Massachusetts**

Dated _____, 2019

TO: _____
(BIDDER)

ADDRESS: _____

PROJECT: Downtown Improvement Project Phase II Intersections

TOWN'S CONTRACT NO. n/a

CONTRACT FOR _____

(Insert Name of Contract as it appears in the Bidding Documents)

You are notified that the Contract Times under the above contract: will commence to run on _____, 2019. By that date, you are to start performing your obligations under the Contract Documents. In accordance with Article 3 of the Agreement the dates of Substantial Completion and completion and readiness for final payment are _____, 2019, and _____, 2019.

Before you may start any Work at the site Article 11 of the General Conditions provides that you and TOWN must each deliver to the other (with copies to ENGINEER and other identified additional insureds) certificates which each is required to purchase and maintain in accordance with Contract Documents.

Also before you may start any Work at the site, you must
(add other requirements)

(TOWN OF MANCHESTER BY THE SEA)

By: _____
(Authorized Signature)

(Title)

ACCEPTANCE OF THE AWARD

(CONTRACTOR)

By: _____
(Authorized Signature)

(Title)

COPY to ENGINEER
(Use Certified Mail. Return Receipt Requested)

(Date)



Vanasse Hangen Brustlin, Inc.
 Transportation * Land Development * Environmental Services
 101 Walnut Street, P.O. Box 9151
 Watertown, Massachusetts 02471-9151
 617-924-1770 FAX 617-924-2286

APPLICATION AND CERTIFICATE FOR PAYMENT

Page _____ of _____ Pages

TO (Owner): PROJECT

APPLICATION NO:

ENGINEER'S PROJECT NO:

APPLICATION DATE:

Distribution to:

PERIOD FROM:
TO:

- OWNER
- ENGINEER
- CONTRACTOR

ATTENTION:

CONTRACTOR'S APPLICATION FOR PAYMENT

The undersigned Contractor certifies that to the best of his knowledge, information and belief the Work covered by this Application for Payment has been completed in accordance with the Contract Documents, that all amounts have been paid by him for Work for which previous Certificates for Payment were issued and payments received from the Owner, and that current payment shown herein is now due:

CONTRACTOR:

By: _____ Date _____

State of: _____ County of: _____

Subscribed and sworn to before me this _____ day of _____, 20____

Notary Public: _____

My Commission expires: _____

Application is made for Payment, as shown below, in connection with the Contract Continuation Sheet is attached.

The present status of the account for this Contract is as follows:

ORIGINAL CONTRACT SUM.....	\$ _____
Net change by Change Orders and Extra Work Orders.....	\$ _____
CONTRACT SUM TO DATE.....	\$ _____
<hr/>	
TOTAL COMPLETED TO DATE.....	\$ _____
RETAINAGE _____%.....	\$ _____
TOTAL LESS RETAINAGE.....	\$ _____
LESS PREVIOUS APPLICATIONS FOR PAYMENTS	\$ _____
APPLICATION NO.....	\$ _____

ENGINEER'S CERTIFICATE FOR PAYMENT

In accordance with the Contract Documents, based on the on-site observations and the data comprising the above application, the Engineer certifies to the Owner that the Work has progressed to the point indicated: that to the best of his knowledge, information and belief, the quality of the Work is in accordance with the Contract Documents; and that the Contractor is entitled to Payment of the AMOUNT CERTIFIED.

AMOUNT CERTIFIED..... \$ _____
 (Attach explanation if amount certified differs from the amount applied for.)

ENGINEER:

By _____ Date _____

This Certificate is not negotiable. The *AMOUNT CERTIFIED* is payable only to the Contractor named herein. Issuance, payment and acceptance of payment are without prejudice to any rights of the Owner or Contractor under this Contract.

OWNER'S APPROVAL

This application for payment is hereby approved in the amount of \$ _____ Date: _____

Town of Manchester by the Sea
 10 Central Street
 Manchester by the Sea, MA 01923 By: _____

APPLICATION AND CERTIFICATE FOR PAYMENT CONT'D



Vanasse Hangen Brustlin, Inc.
 Transportation * Land Development * Environmental Services
 101 Walnut Street, P.O. Box 9151
 Watertown, Massachusetts 02471-9151
 617-924-1770 FAX 617-924-2286

Page of Pages

APPLICATION NO:
 APPLICATION DATE:
 PERIOD FROM:
 TO:
 ENGINEER'S PROJECT NO.

CONTRACT:

ITEM NO.	DESCRIPTION	ESTIMATED QUANTITY	UNIT	CONTRACT PRICE	TOTAL THIS ESTIMATE	VALUE THIS EST.	TOTAL TO DATE	VALUE TO DATE
	CARRIED FORWARD							
	SUBTOTAL:							
	EXTRA WORK ORDERS – NO.							
	CHANGE ORDERS – NO.							
	MATERIALS ON SITE							
	TOTAL:							

CHANGE ORDER

PROJECT IDENTIFICATION: **Downtown Improvement Project
Phase II Intersections
Manchester by the Sea, Massachusetts**

(Instructions on next page)

Change Order No. _____

PROJECT _____ Downtown Improvement Project Phase II Intersections _____

DATE OF ISSUANCE _____ EFFECTIVE DATE _____

TOWN _____ Town of Manchester by the Sea, Department of Public Works _____

TOWN's Contract No. _____ N/A _____

CONTRACTOR _____ ENGINEER _____ Vanasse Hangen Brustlin, Inc. _____

You are directed to make the following changes in the Contract Documents.

Description:

Reason for Change Order:

Attachments: (List documents supporting change)

CHANGE IN CONTRACT PRICE:	CHANGE IN CONTRACT TIMES:
Original Contract Price \$ _____	Original Contract Times Substantial Completion: _____ Ready for final payment: _____ days or dates
Net changes from previous Change Orders No. ___ to No. ___ \$ _____	Net change from previous Change Orders No. ___ to No. ___ _____ days
Contract Price prior to this Change Order \$ _____	Contract Times prior to this Change Order Substantial Completion: _____ Ready for payment: _____ days or dates
Net Increase (decrease) of this Change Order \$ _____	Net increase (decrease) of this Change Order _____ days
Contract Price with all approved Change Orders \$ _____	Contract Times with all approved Change Orders Substantial Completion: _____ Ready for final payment: _____ days or dates

RECOMMENDED:

By: _____
ENGINEER (Authorized Signature)

APPROVED:

By: _____
TOWN ACCOUNTANT (Authorized Signature)

APPROVED:

By: _____
TOWN COUNSEL (Authorized Signature)

ACCEPTED:

By: _____
CONTRACTOR (Authorized Signature)

CHANGE ORDER INSTRUCTIONS

A. GENERAL INFORMATION

This document was developed to provide a uniform format for handling contract changes that affect Contract Price or Contract Times. Changes that have been initiated by a Work Change Directive must be incorporated into a subsequent Change Order if they affect Contract Price or Times.

Changes that affect Contract Price or Contract Times should be promptly covered by a Change Order. The practice of accumulating change order items to reduce the administrative burden may lead to unnecessary disputes.

If Milestones have been listed, any effect of a Change Order thereon should be addressed.

For supplemental instructions and minor changes not involving a change in the Contract Price or Contract Times, a Field Order may be used.

B. COMPLETING THE CHANGE ORDER FORM

ENGINEER initiates the form, including a description of the changes involved and attachments based upon documents and proposals submitted by CONTRACTOR, or requests from TOWN, or both.

Once ENGINEER has completed and signed the form, all copies should be sent to CONTRACTOR for approval. After approval by CONTRACTOR, all copies should be sent to TOWN for approval. ENGINEER should make distribution of executed copies after approval by TOWN.

If a change only applies to Contract Price or to Contract Times, cross out the part of the tabulation that does not apply.

WORK CHANGE DIRECTIVE

PROJECT IDENTIFICATION: **Downtown Improvement Project
Phase II Intersections
Manchester by the Sea, Massachusetts**

(Instructions on next page)

Work Change Directive No. _____

PROJECT Downtown Improvement Project Phase II Intersections

DATE OF ISSUANCE _____ EFFECTIVE DATE _____

TOWN Town of Manchester by the Sea, Department of Public Works

TOWN's Contract No. N/A

CONTRACTOR _____ ENGINEER Vanasse Hangen Brustlin, Inc.

You are directed to proceed promptly with the following change(s):

Description:

Purpose of Work Change Directive:

Attachments: (List documents supporting change)

If a claim is made that the above change(s) have affected Contract Price or Contract Times any claim for a Change Order based thereon will involve one or more of the following methods of determining the effect of the change(s).

Method of determining change in Contract Price:

- Unit Prices
- Lump Sum
- Other _____

Estimated increase (decrease) in Contract Price:
\$ _____

If the change involves an increase, the estimated amount is not to be exceeded without further authorization.

Method of determining change in Contract Times:

- Contractor's records
- Engineer's records
- Other _____

Estimated increase (decrease) in Contract Times:

Substantial Completion: _____ days;
Ready for final payment: _____ days.
If the change involves an increase, the estimated times are not to be exceeded without further authorization.

RECOMMENDED:

ENGINEER

By: _____
(Authorized Signature)

AUTHORIZED:

TOWN

By: _____
(Authorized Signature)

WORK CHANGE DIRECTIVE INSTRUCTIONS

A. GENERAL INFORMATION

This document was developed for use in situations involving changes in the Work which, if not processed expeditiously, might delay the Project. These changes are often initiated in the field and may affect the Contract Price or the Contract Times. This is not a Change Order, but only a directive to proceed with Work that may be included in a subsequent Change Order.

For supplemental instructions and minor changes not involving a possible change in the Contract Price or the Contract Times a Field Order may be used.

B. COMPLETING THE WORK CHANGE DIRECTIVE FORM

ENGINEER initiates the form, including a description of the items involved and attachments.

Based in conversations between ENGINEER and CONTRACTOR, ENGINEER completes the following:

METHOD OF DETERMINING CHANGE, IF ANY, IN CONTRACT PRICE: Mark the method to be used in determining the final cost of Work involved and the estimated net effect on the Contract Price. If the change involves an increase in the Contract Price and the estimated amount is approached before the additional or changed Work is completed, another Work Change Directive must be issued to change the estimated price or Contractor may stop the changed Work when the estimated price is reached. If the Work Change Directive is not likely to change the Contract Price, the space for estimated increase (decrease) should be marked "Not Applicable".

METHOD OF DETERMINING CHANGE, IF ANY, IN CONTRACT TIMES: Mark the method to be used in determining the change in Contract Times and the estimated increase or decrease in Contract Times. If the change involves an increase in the contract Times and the estimated times are approached before the additional or changed Work is completed, another Work Change Directive must be issued to change the times or CONTRACTOR may stop the changed Work when the estimated times are reached. If the Work Change Directive is not likely to change the Contract Times, the space for estimated increase (decrease) should be marked "Not Applicable".

Once ENGINEER has completed and signed the form, all copies should be sent to the TOWN for authorization because ENGINEER alone does not have authority to authorize changes in Price or Times. Once authorized by the TOWN, a copy should be sent by ENGINEER to CONTRACTOR. Price and Times may only be changed by Change Order signed by the TOWN and CONTRACTOR with ENGINEER's recommendation.

Once the Work covered by this directive is completed or final cost and times are determined, CONTRACTOR should submit documentation for inclusion in a Change Order.

THIS IS A DIRECTIVE TO PROCEED WITH A CHANGE THAT MAY AFFECT THE CONTRACT PRICE OR THE CONTRACT TIMES. A CHANGE ORDER, IF ANY, SHOULD BE CONSIDERED PROMPTLY.

CERTIFICATE OF SUBSTANTIAL COMPLETION

PROJECT: **Downtown Improvement Project
Phase II Intersections
Manchester by the Sea, Massachusetts**

DATE OF ISSUANCE: _____

TOWN: Town of Manchester by the Sea, MA

TOWN's Contract No. N/A

CONTRACTOR: _____

ENGINEER: Vanasse Hangen Brustlin, Inc.

This Certificate of Substantial Completion applies to all Work under the Contract Documents or to the following specified parts thereof:

To: _____
TOWN (Authorized Signature)

And To: _____
CONTRACTOR (Authorized Signature)

The Work to which this Certificate applies has been inspected by authorized representatives of TOWN, CONTRACTOR and ENGINEER, and that Work is hereby declared to be substantially complete in accordance with the Contract Documents on

DATE OF SUBSTANTIAL COMPLETION

A tentative list of items to be completed or corrected is attached hereto. This list may not be all-inclusive, and the failure to include an item in it does not alter the responsibility of the CONTRACTOR to complete all the Work in accordance with the Contract Documents. The items in the tentative list shall be completed or corrected by CONTRACTOR within _____ days of the above Substantial Completion.

**GENERAL CONDITIONS
OF CONTRACT**

This document has important legal consequences; consultation with an attorney is encouraged with respect to its use or modification. This document should be adapted to the particular circumstances of the contemplated Project and the controlling Laws and Regulations.

**STANDARD GENERAL CONDITIONS
OF THE CONSTRUCTION CONTRACT**

Prepared by

ENGINEERS JOINT CONTRACT DOCUMENTS COMMITTEE

and

Issued and Published Jointly by

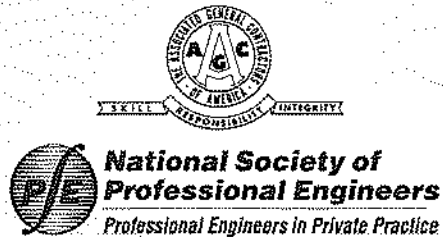
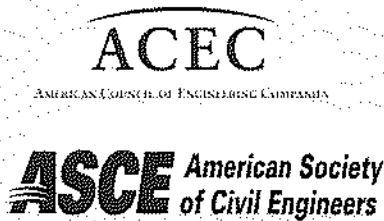

AMERICAN COUNCIL OF ENGINEERING COMPANIES

ASSOCIATED GENERAL CONTRACTORS OF AMERICA

AMERICAN SOCIETY OF CIVIL ENGINEERS

PROFESSIONAL ENGINEERS IN PRIVATE PRACTICE
A Practice Division of the
NATIONAL SOCIETY OF PROFESSIONAL ENGINEERS

Endorsed by



CONSTRUCTION SPECIFICATIONS INSTITUTE

These General Conditions have been prepared for use with the Suggested Forms of Agreement Between Owner and Contractor (EJCDC C-520 or C-525, 2007 Editions). Their provisions are interrelated and a change in one may necessitate a change in the other. Comments concerning their usage are contained in the Narrative Guide to the EJCDC Construction Documents (EJCDC C-001, 2007 Edition). For guidance in the preparation of Supplementary Conditions, see Guide to the Preparation of Supplementary Conditions (EJCDC C-800, 2007 Edition).

Copyright © 2007 National Society of Professional Engineers
1420 King Street, Alexandria, VA 22314-2794
(703) 684-2882
www.nspe.org

American Council of Engineering Companies
1015 15th Street N.W., Washington, DC 20005
(202) 347-7474
www.acec.org

American Society of Civil Engineers
1801 Alexander Bell Drive, Reston, VA 20191-4400
(800) 548-2723
www.asce.org

Associated General Contractors of America
2300 Wilson Boulevard, Suite 400, Arlington, VA 22201-3308
(703) 548-3118
www.agc.org

The copyright for this EJCDC document is owned jointly by the four
EJCDC sponsoring organizations and held in trust for their benefit by NSPE.

STANDARD GENERAL CONDITIONS OF THE
CONSTRUCTION CONTRACT

TABLE OF CONTENTS

	Page
Article 1 – Definitions and Terminology	6
1.01 Defined Terms	6
1.02 Terminology	9
Article 2 – Preliminary Matters	9
2.01 Delivery of Bonds and Evidence of Insurance	9
2.02 Copies of Documents	10
2.03 Commencement of Contract Times; Notice to Proceed	10
2.04 Starting the Work	10
2.05 Before Starting Construction	10
2.06 Preconstruction Conference; Designation of Authorized Representatives	10
2.07 Initial Acceptance of Schedules	10
Article 3 – Contract Documents: Intent, Amending, Reuse	11
3.01 Intent	11
3.02 Reference Standards	11
3.03 Reporting and Resolving Discrepancies	11
3.04 Amending and Supplementing Contract Documents	12
3.05 Reuse of Documents	12
3.06 Electronic Data	12
Article 4 – Availability of Lands; Subsurface and Physical Conditions; Hazardous Environmental Conditions; Reference Points	12
4.01 Availability of Lands	12
4.02 Subsurface and Physical Conditions	13
4.03 Differing Subsurface or Physical Conditions	13
4.04 Underground Facilities	14
4.05 Reference Points	15
4.06 Hazardous Environmental Condition at Site	15
Article 5 – Bonds and Insurance	16
5.01 Performance, Payment, and Other Bonds	16
5.02 Licensed Sureties and Insurers	17
5.03 Certificates of Insurance	17
5.04 Contractor’s Insurance	17
5.05 Owner’s Liability Insurance	18
5.06 Property Insurance	18
5.07 Waiver of Rights	19
5.08 Receipt and Application of Insurance Proceeds	20
5.09 Acceptance of Bonds and Insurance; Option to Replace	20
5.10 Partial Utilization, Acknowledgment of Property Insurer	20
Article 6 – Contractor’s Responsibilities	21
6.01 Supervision and Superintendence	21
6.02 Labor; Working Hours	21
6.03 Services, Materials, and Equipment	21
6.04 Progress Schedule	21
6.05 Substitutes and “Or-Equals”	21
6.06 Concerning Subcontractors, Suppliers, and Others	23

6.07	Patent Fees and Royalties.....	24
6.08	Permits	25
6.09	Laws and Regulations	25
6.10	Taxes.....	25
6.11	Use of Site and Other Areas.....	25
6.12	Record Documents	26
6.13	Safety and Protection.....	26
6.14	Safety Representative	27
6.15	Hazard Communication Programs	27
6.16	Emergencies.....	27
6.17	Shop Drawings and Samples.....	27
6.18	Continuing the Work.....	28
6.19	Contractor's General Warranty and Guarantee	28
6.20	Indemnification.....	29
6.21	Delegation of Professional Design Services	29
Article 7 – Other Work at the Site		30
7.01	Related Work at Site.....	30
7.02	Coordination	30
7.03	Legal Relationships	31
Article 8 – Owner's Responsibilities		31
8.01	Communications to Contractor	31
8.02	Replacement of Engineer	31
8.03	Furnish Data	31
8.04	Pay When Due.....	31
8.05	Lands and Easements; Reports and Tests	31
8.06	Insurance.....	31
8.07	Change Orders.....	31
8.08	Inspections, Tests, and Approvals.....	31
8.09	Limitations on Owner's Responsibilities	31
8.10	Undisclosed Hazardous Environmental Condition.....	31
8.11	Evidence of Financial Arrangements	31
8.12	Compliance with Safety Program	31
Article 9 – Engineer's Status During Construction		32
9.01	Owner's Representative	32
9.02	Visits to Site.....	32
9.03	Project Representative.....	32
9.04	Authorized Variations in Work.....	32
9.05	Rejecting Defective Work.....	32
9.06	Shop Drawings, Change Orders and Payments	32
9.07	Determinations for Unit Price Work	33
9.08	Decisions on Requirements of Contract Documents and Acceptability of Work	33
9.09	Limitations on Engineer's Authority and Responsibilities.....	33
9.10	Compliance with Safety Program	34
Article 10 – Changes in the Work; Claims		34
10.01	Authorized Changes in the Work.....	34
10.02	Unauthorized Changes in the Work.....	34
10.03	Execution of Change Orders	34
10.04	Notification to Surety	34
10.05	Claims	34
Article 11 – Cost of the Work; Allowances; Unit Price Work.....		35
11.01	Cost of the Work	35

11.02	Allowances	37
11.03	Unit Price Work.....	37
Article 12 – Change of Contract Price; Change of Contract Times.....		38
12.01	Change of Contract Price	38
12.02	Change of Contract Times.....	39
12.03	Delays	39
Article 13 – Tests and Inspections; Correction, Removal or Acceptance of Defective Work.....		39
13.01	Notice of Defects.....	39
13.02	Access to Work	39
13.03	Tests and Inspections.....	40
13.04	Uncovering Work.....	40
13.05	Owner May Stop the Work.....	40
13.06	Correction or Removal of Defective Work.....	41
13.07	Correction Period.....	41
13.08	Acceptance of Defective Work	41
13.09	Owner May Correct Defective Work.....	42
Article 14 – Payments to Contractor and Completion.....		42
14.01	Schedule of Values.....	42
14.02	Progress Payments.....	42
14.03	Contractor’s Warranty of Title.....	44
14.04	Substantial Completion	44
14.05	Partial Utilization.....	45
14.06	Final Inspection	45
14.07	Final Payment.....	46
14.08	Final Completion Delayed	46
14.09	Waiver of Claims.....	47
Article 15 – Suspension of Work and Termination.....		47
15.01	Owner May Suspend Work.....	47
15.02	Owner May Terminate for Cause.....	47
15.03	Owner May Terminate For Convenience	48
15.04	Contractor May Stop Work or Terminate.....	48
Article 16 – Dispute Resolution.....		48
16.01	Methods and Procedures	48
Article 17 – Miscellaneous.....		49
17.01	Giving Notice	49
17.02	Computation of Times.....	49
17.03	Cumulative Remedies.....	49
17.04	Survival of Obligations	49
17.05	Controlling Law.....	49
17.06	Headings	49

ARTICLE I -- DEFINITIONS AND TERMINOLOGY

1.01 Defined Terms

A. Wherever used in the Bidding Requirements or Contract Documents and printed with initial capital letters, the terms listed below will have the meanings indicated which are applicable to both the singular and plural thereof. In addition to terms specifically defined, terms with initial capital letters in the Contract Documents include references to identified articles and paragraphs, and the titles of other documents or forms.

1. *Addenda*—Written or graphic instruments issued prior to the opening of Bids which clarify, correct, or change the Bidding Requirements or the proposed Contract Documents.
2. *Agreement*—The written instrument which is evidence of the agreement between Owner and Contractor covering the Work.
3. *Application for Payment*—The form acceptable to Engineer which is to be used by Contractor during the course of the Work in requesting progress or final payments and which is to be accompanied by such supporting documentation as is required by the Contract Documents.
4. *Asbestos*—Any material that contains more than one percent asbestos and is friable or is releasing asbestos fibers into the air above current action levels established by the United States Occupational Safety and Health Administration.
5. *Bid*—The offer or proposal of a Bidder submitted on the prescribed form setting forth the prices for the Work to be performed.
6. *Bidder*—The individual or entity who submits a Bid directly to Owner.
7. *Bidding Documents*—The Bidding Requirements and the proposed Contract Documents (including all Addenda).
8. *Bidding Requirements*—The advertisement or invitation to bid, Instructions to Bidders, Bid security of acceptable form, if any, and the Bid Form with any supplements.
9. *Change Order*—A document recommended by Engineer which is signed by Contractor and Owner and authorizes an addition, deletion, or revision in the Work or an adjustment in the Contract Price or the Contract Times, issued on or after the Effective Date of the Agreement.
10. *Claim*—A demand or assertion by Owner or Contractor seeking an adjustment of Contract Price or Contract Times, or both, or other relief with respect to the terms of the Contract. A demand for money or services by a third party is not a Claim.
11. *Contract*—The entire and integrated written agreement between the Owner and Contractor concerning the Work. The Contract supercedes prior negotiations, representations, or agreements, whether written or oral.
12. *Contract Documents*—Those items so designated in the Agreement. Only printed or hard copies of the items listed in the Agreement are Contract Documents. Approved Shop Drawings, other Contractor submittals, and the reports and drawings of subsurface and physical conditions are not Contract Documents.
13. *Contract Price*—The moneys payable by Owner to Contractor for completion of the Work in accordance with the Contract Documents as stated in the Agreement (subject to the provisions of Paragraph 11.03 in the case of Unit Price Work).
14. *Contract Times*—The number of days or the dates stated in the Agreement to: (i) achieve Milestones, if any; (ii) achieve Substantial Completion; and (iii) complete the Work so that it is ready for final payment as evidenced by Engineer's written recommendation of final payment.
15. *Contractor*—The individual or entity with whom Owner has entered into the Agreement.
16. *Cost of the Work*—See Paragraph 11.01 for definition.
17. *Drawings*—That part of the Contract Documents prepared or approved by Engineer which graphically shows the scope, extent, and character of the Work to be

performed by Contractor. Shop Drawings and other Contractor submittals are not Drawings as so defined.

18. *Effective Date of the Agreement*—The date indicated in the Agreement on which it becomes effective, but if no such date is indicated, it means the date on which the Agreement is signed and delivered by the last of the two parties to sign and deliver.
19. *Engineer*—The individual or entity named as such in the Agreement.
20. *Field Order*—A written order issued by Engineer which requires minor changes in the Work but which does not involve a change in the Contract Price or the Contract Times.
21. *General Requirements*—Sections of Division 1 of the Specifications.
22. *Hazardous Environmental Condition*—The presence at the Site of Asbestos, PCBs, Petroleum, Hazardous Waste, or Radioactive Material in such quantities or circumstances that may present a substantial danger to persons or property exposed thereto.
23. *Hazardous Waste*—The term Hazardous Waste shall have the meaning provided in Section 1004 of the Solid Waste Disposal Act (42 USC Section 6903) as amended from time to time.
24. *Laws and Regulations; Laws or Regulations*—Any and all applicable laws, rules, regulations, ordinances, codes, and orders of any and all governmental bodies, agencies, authorities, and courts having jurisdiction.
25. *Liens*—Charges, security interests, or encumbrances upon Project funds, real property, or personal property.
26. *Milestone*—A principal event specified in the Contract Documents relating to an intermediate completion date or time prior to Substantial Completion of all the Work.
27. *Notice of Award*—The written notice by Owner to the Successful Bidder stating that upon timely compliance by the Successful Bidder with the conditions precedent listed therein, Owner will sign and deliver the Agreement.
28. *Notice to Proceed*—A written notice given by Owner to Contractor fixing the date on which the Contract Times will commence to run and on which Contractor shall start to perform the Work under the Contract Documents.
29. *Owner*—The individual or entity with whom Contractor has entered into the Agreement and for whom the Work is to be performed.
30. *PCBs*—Polychlorinated biphenyls.
31. *Petroleum*—Petroleum, including crude oil or any fraction thereof which is liquid at standard conditions of temperature and pressure (60 degrees Fahrenheit and 14.7 pounds per square inch absolute), such as oil, petroleum, fuel oil, oil sludge, oil refuse, gasoline, kerosene, and oil mixed with other non-Hazardous Waste and crude oils.
32. *Progress Schedule*—A schedule, prepared and maintained by Contractor, describing the sequence and duration of the activities comprising the Contractor's plan to accomplish the Work within the Contract Times.
33. *Project*—The total construction of which the Work to be performed under the Contract Documents may be the whole, or a part.
34. *Project Manual*—The bound documentary information prepared for bidding and constructing the Work. A listing of the contents of the Project Manual, which may be bound in one or more volumes, is contained in the table(s) of contents.
35. *Radioactive Material*—Source, special nuclear, or byproduct material as defined by the Atomic Energy Act of 1954 (42 USC Section 2011 et seq.) as amended from time to time.
36. *Resident Project Representative*—The authorized representative of Engineer who may be assigned to the Site or any part thereof.
37. *Samples*—Physical examples of materials, equipment, or workmanship that are representative of some portion of the Work

- and which establish the standards by which such portion of the Work will be judged.
38. *Schedule of Submittals*—A schedule, prepared and maintained by Contractor, of required submittals and the time requirements to support scheduled performance of related construction activities.
 39. *Schedule of Values*—A schedule, prepared and maintained by Contractor, allocating portions of the Contract Price to various portions of the Work and used as the basis for reviewing Contractor's Applications for Payment.
 40. *Shop Drawings*—All drawings, diagrams, illustrations, schedules, and other data or information which are specifically prepared or assembled by or for Contractor and submitted by Contractor to illustrate some portion of the Work.
 41. *Site*—Lands or areas indicated in the Contract Documents as being furnished by Owner upon which the Work is to be performed, including rights-of-way and easements for access thereto, and such other lands furnished by Owner which are designated for the use of Contractor.
 42. *Specifications*—That part of the Contract Documents consisting of written requirements for materials, equipment, systems, standards and workmanship as applied to the Work, and certain administrative requirements and procedural matters applicable thereto.
 43. *Subcontractor*—An individual or entity having a direct contract with Contractor or with any other Subcontractor for the performance of a part of the Work at the Site.
 44. *Substantial Completion*—The time at which the Work (or a specified part thereof) has progressed to the point where, in the opinion of Engineer, the Work (or a specified part thereof) is sufficiently complete, in accordance with the Contract Documents, so that the Work (or a specified part thereof) can be utilized for the purposes for which it is intended. The terms "substantially complete" and "substantially completed" as applied to all or part of the Work refer to Substantial Completion thereof.
 45. *Successful Bidder*—The Bidder submitting a responsive Bid to whom Owner makes an award.
 46. *Supplementary Conditions*—That part of the Contract Documents which amends or supplements these General Conditions.
 47. *Supplier*—A manufacturer, fabricator, supplier, distributor, materialman, or vendor having a direct contract with Contractor or with any Subcontractor to furnish materials or equipment to be incorporated in the Work by Contractor or Subcontractor.
 48. *Underground Facilities*—All underground pipelines, conduits, ducts, cables, wires, manholes, vaults, tanks, tunnels, or other such facilities or attachments, and any encasements containing such facilities, including those that convey electricity, gases, steam, liquid petroleum products, telephone or other communications, cable television, water, wastewater, storm water, other liquids or chemicals, or traffic or other control systems.
 49. *Unit Price Work*—Work to be paid for on the basis of unit prices.
 50. *Work*—The entire construction or the various separately identifiable parts thereof required to be provided under the Contract Documents. Work includes and is the result of performing or providing all labor, services, and documentation necessary to produce such construction, and furnishing, installing, and incorporating all materials and equipment into such construction, all as required by the Contract Documents.
 51. *Work Change Directive*—A written statement to Contractor issued on or after the Effective Date of the Agreement and signed by Owner and recommended by Engineer ordering an addition, deletion, or revision in the Work, or responding to differing or unforeseen subsurface or physical conditions under which the Work is to be performed or to emergencies. A Work Change Directive will not change the Contract Price or the Contract Times but is evidence that the parties expect that the change ordered or documented by a Work Change Directive will be incorporated in a subsequently issued Change Order following negotiations by the parties as to its

effect, if any, on the Contract Price or Contract Times.

1.02 Terminology

A. The words and terms discussed in Paragraph 1.02.B through F are not defined but, when used in the Bidding Requirements or Contract Documents, have the indicated meaning.

B. Intent of Certain Terms or Adjectives:

1. The Contract Documents include the terms "as allowed," "as approved," "as ordered," "as directed" or terms of like effect or import to authorize an exercise of professional judgment by Engineer. In addition, the adjectives "reasonable," "suitable," "acceptable," "proper," "satisfactory," or adjectives of like effect or import are used to describe an action or determination of Engineer as to the Work. It is intended that such exercise of professional judgment, action, or determination will be solely to evaluate, in general, the Work for compliance with the information in the Contract Documents and with the design concept of the Project as a functioning whole as shown or indicated in the Contract Documents (unless there is a specific statement indicating otherwise). The use of any such term or adjective is not intended to and shall not be effective to assign to Engineer any duty or authority to supervise or direct the performance of the Work, or any duty or authority to undertake responsibility contrary to the provisions of Paragraph 9.09 or any other provision of the Contract Documents.

C. Day:

1. The word "day" means a calendar day of 24 hours measured from midnight to the next midnight.

D. Defective:

1. The word "defective," when modifying the word "Work," refers to Work that is unsatisfactory, faulty, or deficient in that it:

- a. does not conform to the Contract Documents; or
- b. does not meet the requirements of any applicable inspection, reference standard,

test, or approval referred to in the Contract Documents; or

c. has been damaged prior to Engineer's recommendation of final payment (unless responsibility for the protection thereof has been assumed by Owner at Substantial Completion in accordance with Paragraph 14.04 or 14.05).

E. Furnish, Install, Perform, Provide:

1. The word "furnish," when used in connection with services, materials, or equipment, shall mean to supply and deliver said services, materials, or equipment to the Site (or some other specified location) ready for use or installation and in usable or operable condition.

2. The word "install," when used in connection with services, materials, or equipment, shall mean to put into use or place in final position said services, materials, or equipment complete and ready for intended use.

3. The words "perform" or "provide," when used in connection with services, materials, or equipment, shall mean to furnish and install said services, materials, or equipment complete and ready for intended use.

4. When "furnish," "install," "perform," or "provide" is not used in connection with services, materials, or equipment in a context clearly requiring an obligation of Contractor, "provide" is implied.

F. Unless stated otherwise in the Contract Documents, words or phrases that have a well-known technical or construction industry or trade meaning are used in the Contract Documents in accordance with such recognized meaning.

ARTICLE 2 – PRELIMINARY MATTERS

2.01 Delivery of Bonds and Evidence of Insurance

A. When Contractor delivers the executed counterparts of the Agreement to Owner, Contractor shall also deliver to Owner such bonds as Contractor may be required to furnish.

B. *Evidence of Insurance:* Before any Work at the Site is started, Contractor and Owner shall each deliver to the other, with copies to each additional

insured identified in the Supplementary Conditions, certificates of insurance (and other evidence of insurance which either of them or any additional insured may reasonably request) which Contractor and Owner respectively are required to purchase and maintain in accordance with Article 5.

2.02 Copies of Documents

- A. Owner shall furnish to Contractor up to ten printed or hard copies of the Drawings and Project Manual. Additional copies will be furnished upon request at the cost of reproduction.

2.03 Commencement of Contract Times; Notice to Proceed

- A. The Contract Times will commence to run on the thirtieth day after the Effective Date of the Agreement or, if a Notice to Proceed is given, on the day indicated in the Notice to Proceed. A Notice to Proceed may be given at any time within 30 days after the Effective Date of the Agreement. In no event will the Contract Times commence to run later than the sixtieth day after the day of Bid opening or the thirtieth day after the Effective Date of the Agreement, whichever date is earlier.

2.04 Starting the Work

- A. Contractor shall start to perform the Work on the date when the Contract Times commence to run. No Work shall be done at the Site prior to the date on which the Contract Times commence to run.

2.05 Before Starting Construction

- A. *Preliminary Schedules:* Within 10 days after the Effective Date of the Agreement (unless otherwise specified in the General Requirements), Contractor shall submit to Engineer for timely review:
 - 1. a preliminary Progress Schedule indicating the times (numbers of days or dates) for starting and completing the various stages of the Work, including any Milestones specified in the Contract Documents;
 - 2. a preliminary Schedule of Submittals; and
 - 3. a preliminary Schedule of Values for all of the Work which includes quantities and prices of items which when added together equal the Contract Price and subdivides the Work into component parts in sufficient

detail to serve as the basis for progress payments during performance of the Work. Such prices will include an appropriate amount of overhead and profit applicable to each item of Work.

2.06 Preconstruction Conference; Designation of Authorized Representatives

- A. Before any Work at the Site is started, a conference attended by Owner, Contractor, Engineer, and others as appropriate will be held to establish a working understanding among the parties as to the Work and to discuss the schedules referred to in Paragraph 2.05.A, procedures for handling Shop Drawings and other submittals, processing Applications for Payment, and maintaining required records.
- B. At this conference Owner and Contractor each shall designate, in writing, a specific individual to act as its authorized representative with respect to the services and responsibilities under the Contract. Such individuals shall have the authority to transmit instructions, receive information, render decisions relative to the Contract, and otherwise act on behalf of each respective party.

2.07 Initial Acceptance of Schedules

- A. At least 10 days before submission of the first Application for Payment a conference attended by Contractor, Engineer, and others as appropriate will be held to review for acceptability to Engineer as provided below the schedules submitted in accordance with Paragraph 2.05.A. Contractor shall have an additional 10 days to make corrections and adjustments and to complete and resubmit the schedules. No progress payment shall be made to Contractor until acceptable schedules are submitted to Engineer.
 - 1. The Progress Schedule will be acceptable to Engineer if it provides an orderly progression of the Work to completion within the Contract Times. Such acceptance will not impose on Engineer responsibility for the Progress Schedule, for sequencing, scheduling, or progress of the Work, nor interfere with or relieve Contractor from Contractor's full responsibility therefor.
 - 2. Contractor's Schedule of Submittals will be acceptable to Engineer if it provides a

workable arrangement for reviewing and processing the required submittals.

3. Contractor's Schedule of Values will be acceptable to Engineer as to form and substance if it provides a reasonable allocation of the Contract Price to component parts of the Work.

ARTICLE 3 – CONTRACT DOCUMENTS: INTENT, AMENDING, REUSE

3.01 Intent

- A. The Contract Documents are complementary; what is required by one is as binding as if required by all.
- B. It is the intent of the Contract Documents to describe a functionally complete project (or part thereof) to be constructed in accordance with the Contract Documents. Any labor, documentation, services, materials, or equipment that reasonably may be inferred from the Contract Documents or from prevailing custom or trade usage as being required to produce the indicated result will be provided whether or not specifically called for, at no additional cost to Owner.
- C. Clarifications and interpretations of the Contract Documents shall be issued by Engineer as provided in Article 9.

3.02 Reference Standards

- A. Standards, Specifications, Codes, Laws, and Regulations
 1. Reference to standards, specifications, manuals, or codes of any technical society, organization, or association, or to Laws or Regulations, whether such reference be specific or by implication, shall mean the standard, specification, manual, code, or Laws or Regulations in effect at the time of opening of Bids (or on the Effective Date of the Agreement if there were no Bids), except as may be otherwise specifically stated in the Contract Documents.
 2. No provision of any such standard, specification, manual, or code, or any instruction of a Supplier, shall be effective to change the duties or responsibilities of Owner, Contractor, or Engineer, or any of their subcontractors, consultants, agents, or

employees, from those set forth in the Contract Documents. No such provision or instruction shall be effective to assign to Owner, Engineer, or any of their officers, directors, members, partners, employees, agents, consultants, or subcontractors, any duty or authority to supervise or direct the performance of the Work or any duty or authority to undertake responsibility inconsistent with the provisions of the Contract Documents.

3.03 Reporting and Resolving Discrepancies

A. Reporting Discrepancies:

1. *Contractor's Review of Contract Documents Before Starting Work:* Before undertaking each part of the Work, Contractor shall carefully study and compare the Contract Documents and check and verify pertinent figures therein and all applicable field measurements. Contractor shall promptly report in writing to Engineer any conflict, error, ambiguity, or discrepancy which Contractor discovers, or has actual knowledge of, and shall obtain a written interpretation or clarification from Engineer before proceeding with any Work affected thereby.
2. *Contractor's Review of Contract Documents During Performance of Work:* If, during the performance of the Work, Contractor discovers any conflict, error, ambiguity, or discrepancy within the Contract Documents, or between the Contract Documents and (a) any applicable Law or Regulation, (b) any standard, specification, manual, or code, or (c) any instruction of any Supplier, then Contractor shall promptly report it to Engineer in writing. Contractor shall not proceed with the Work affected thereby (except in an emergency as required by Paragraph 6.16.A) until an amendment or supplement to the Contract Documents has been issued by one of the methods indicated in Paragraph 3.04.
3. Contractor shall not be liable to Owner or Engineer for failure to report any conflict, error, ambiguity, or discrepancy in the Contract Documents unless Contractor had actual knowledge thereof.

B. Resolving Discrepancies:

1. Except as may be otherwise specifically stated in the Contract Documents, the provisions of the Contract Documents shall take precedence in resolving any conflict, error, ambiguity, or discrepancy between the provisions of the Contract Documents and:

a. the provisions of any standard, specification, manual, or code, or the instruction of any Supplier (whether or not specifically incorporated by reference in the Contract Documents); or

b. the provisions of any Laws or Regulations applicable to the performance of the Work (unless such an interpretation of the provisions of the Contract Documents would result in violation of such Law or Regulation).

3.04 *Amending and Supplementing Contract Documents*

A. The Contract Documents may be amended to provide for additions, deletions, and revisions in the Work or to modify the terms and conditions thereof by either a Change Order or a Work Change Directive.

B. The requirements of the Contract Documents may be supplemented, and minor variations and deviations in the Work may be authorized, by one or more of the following ways:

1. A Field Order;
2. Engineer's approval of a Shop Drawing or Sample (subject to the provisions of Paragraph 6.17.D.3); or
3. Engineer's written interpretation or clarification.

3.05 *Reuse of Documents*

A. Contractor and any Subcontractor or Supplier shall not:

1. have or acquire any title to or ownership rights in any of the Drawings, Specifications, or other documents (or copies of any thereof) prepared by or bearing the seal of Engineer or its consultants, including electronic media editions; or
2. reuse any such Drawings, Specifications, other documents, or copies thereof on

extensions of the Project or any other project without written consent of Owner and Engineer and specific written verification or adaptation by Engineer.

B. The prohibitions of this Paragraph 3.05 will survive final payment, or termination of the Contract. Nothing herein shall preclude Contractor from retaining copies of the Contract Documents for record purposes.

3.06 *Electronic Data*

A. Unless otherwise stated in the Supplementary Conditions, the data furnished by Owner or Engineer to Contractor, or by Contractor to Owner or Engineer, that may be relied upon are limited to the printed copies (also known as hard copies). Files in electronic media format of text, data, graphics, or other types are furnished only for the convenience of the receiving party. Any conclusion or information obtained or derived from such electronic files will be at the user's sole risk. If there is a discrepancy between the electronic files and the hard copies, the hard copies govern.

B. Because data stored in electronic media format can deteriorate or be modified inadvertently or otherwise without authorization of the data's creator, the party receiving electronic files agrees that it will perform acceptance tests or procedures within 60 days, after which the receiving party shall be deemed to have accepted the data thus transferred. Any errors detected within the 60-day acceptance period will be corrected by the transferring party.

C. When transferring documents in electronic media format, the transferring party makes no representations as to long term compatibility, usability, or readability of documents resulting from the use of software application packages, operating systems, or computer hardware differing from those used by the data's creator.

ARTICLE 4 – AVAILABILITY OF LANDS; SUBSURFACE AND PHYSICAL CONDITIONS; HAZARDOUS ENVIRONMENTAL CONDITIONS; REFERENCE POINTS

4.01 *Availability of Lands*

A. Owner shall furnish the Site. Owner shall notify Contractor of any encumbrances or restrictions not of general application but specifically related to

use of the Site with which Contractor must comply in performing the Work. Owner will obtain in a timely manner and pay for easements for permanent structures or permanent changes in existing facilities. If Contractor and Owner are unable to agree on entitlement to or on the amount or extent, if any, of any adjustment in the Contract Price or Contract Times, or both, as a result of any delay in Owner's furnishing the Site or a part thereof, Contractor may make a Claim therefor as provided in Paragraph 10.05.

B. Upon reasonable written request, Owner shall furnish Contractor with a current statement of record legal title and legal description of the lands upon which the Work is to be performed and Owner's interest therein as necessary for giving notice of or filing a mechanic's or construction lien against such lands in accordance with applicable Laws and Regulations.

C. Contractor shall provide for all additional lands and access thereto that may be required for temporary construction facilities or storage of materials and equipment.

4.02 *Subsurface and Physical Conditions*

A. *Reports and Drawings:* The Supplementary Conditions identify:

1. those reports known to Owner of explorations and tests of subsurface conditions at or contiguous to the Site; and
2. those drawings known to Owner of physical conditions relating to existing surface or subsurface structures at the Site (except Underground Facilities).

B. *Limited Reliance by Contractor on Technical Data Authorized:* Contractor may rely upon the accuracy of the "technical data" contained in such reports and drawings, but such reports and drawings are not Contract Documents. Such "technical data" is identified in the Supplementary Conditions. Except for such reliance on such "technical data," Contractor may not rely upon or make any claim against Owner or Engineer, or any of their officers, directors, members, partners, employees, agents, consultants, or subcontractors with respect to:

1. the completeness of such reports and drawings for Contractor's purposes, including, but not limited to, any aspects of

the means, methods, techniques, sequences, and procedures of construction to be employed by Contractor, and safety precautions and programs incident thereto; or

2. other data, interpretations, opinions, and information contained in such reports or shown or indicated in such drawings; or
3. any Contractor interpretation of or conclusion drawn from any "technical data" or any such other data, interpretations, opinions, or information.

4.03 *Differing Subsurface or Physical Conditions*

A. *Notice:* If Contractor believes that any subsurface or physical condition that is uncovered or revealed either:

1. is of such a nature as to establish that any "technical data" on which Contractor is entitled to rely as provided in Paragraph 4.02 is materially inaccurate; or
2. is of such a nature as to require a change in the Contract Documents; or
3. differs materially from that shown or indicated in the Contract Documents; or
4. is of an unusual nature, and differs materially from conditions ordinarily encountered and generally recognized as inherent in work of the character provided for in the Contract Documents;

then Contractor shall, promptly after becoming aware thereof and before further disturbing the subsurface or physical conditions or performing any Work in connection therewith (except in an emergency as required by Paragraph 6.16.A), notify Owner and Engineer in writing about such condition. Contractor shall not further disturb such condition or perform any Work in connection therewith (except as aforesaid) until receipt of written order to do so.

B. *Engineer's Review:* After receipt of written notice as required by Paragraph 4.03.A, Engineer will promptly review the pertinent condition, determine the necessity of Owner's obtaining additional exploration or tests with respect thereto, and advise Owner in writing (with a copy to Contractor) of Engineer's findings and conclusions.

C. *Possible Price and Times Adjustments:*

1. The Contract Price or the Contract Times, or both, will be equitably adjusted to the extent that the existence of such differing subsurface or physical condition causes an increase or decrease in Contractor's cost of, or time required for, performance of the Work; subject, however, to the following:
 - a. such condition must meet any one or more of the categories described in Paragraph 4.03.A; and
 - b. with respect to Work that is paid for on a unit price basis, any adjustment in Contract Price will be subject to the provisions of Paragraphs 9.07 and 11.03.
2. Contractor shall not be entitled to any adjustment in the Contract Price or Contract Times if:
 - a. Contractor knew of the existence of such conditions at the time Contractor made a final commitment to Owner with respect to Contract Price and Contract Times by the submission of a Bid or becoming bound under a negotiated contract; or
 - b. the existence of such condition could reasonably have been discovered or revealed as a result of any examination, investigation, exploration, test, or study of the Site and contiguous areas required by the Bidding Requirements or Contract Documents to be conducted by or for Contractor prior to Contractor's making such final commitment; or
 - c. Contractor failed to give the written notice as required by Paragraph 4.03.A.
3. If Owner and Contractor are unable to agree on entitlement to or on the amount or extent, if any, of any adjustment in the Contract Price or Contract Times, or both, a Claim may be made therefor as provided in Paragraph 10.05. However, neither Owner or Engineer, or any of their officers, directors, members, partners, employees, agents, consultants, or subcontractors shall be liable to Contractor for any claims, costs, losses, or damages (including but not limited to all fees and charges of engineers, architects, attorneys, and other professionals and all court or

arbitration or other dispute resolution costs) sustained by Contractor on or in connection with any other project or anticipated project.

4.04 *Underground Facilities*

A. *Shown or Indicated:* The information and data shown or indicated in the Contract Documents with respect to existing Underground Facilities at or contiguous to the Site is based on information and data furnished to Owner or Engineer by the owners of such Underground Facilities, including Owner, or by others. Unless it is otherwise expressly provided in the Supplementary Conditions:

1. Owner and Engineer shall not be responsible for the accuracy or completeness of any such information or data provided by others; and
2. the cost of all of the following will be included in the Contract Price, and Contractor shall have full responsibility for:
 - a. reviewing and checking all such information and data;
 - b. locating all Underground Facilities shown or indicated in the Contract Documents;
 - c. coordination of the Work with the owners of such Underground Facilities, including Owner, during construction; and
 - d. the safety and protection of all such Underground Facilities and repairing any damage thereto resulting from the Work.

B. *Not Shown or Indicated:*

1. If an Underground Facility is uncovered or revealed at or contiguous to the Site which was not shown or indicated, or not shown or indicated with reasonable accuracy in the Contract Documents, Contractor shall, promptly after becoming aware thereof and before further disturbing conditions affected thereby or performing any Work in connection therewith (except in an emergency as required by Paragraph 6.16.A), identify the owner of such Underground Facility and give written notice to that owner and to Owner and Engineer. Engineer will promptly review the Underground Facility and determine the

extent, if any, to which a change is required in the Contract Documents to reflect and document the consequences of the existence or location of the Underground Facility. During such time, Contractor shall be responsible for the safety and protection of such Underground Facility.

2. If Engineer concludes that a change in the Contract Documents is required, a Work Change Directive or a Change Order will be issued to reflect and document such consequences. An equitable adjustment shall be made in the Contract Price or Contract Times, or both, to the extent that they are attributable to the existence or location of any Underground Facility that was not shown or indicated or not shown or indicated with reasonable accuracy in the Contract Documents and that Contractor did not know of and could not reasonably have been expected to be aware of or to have anticipated. If Owner and Contractor are unable to agree on entitlement to or on the amount or extent, if any, of any such adjustment in Contract Price or Contract Times, Owner or Contractor may make a Claim therefor as provided in Paragraph 10.05.

4.05 Reference Points

- A. Owner shall provide engineering surveys to establish reference points for construction which in Engineer's judgment are necessary to enable Contractor to proceed with the Work. Contractor shall be responsible for laying out the Work, shall protect and preserve the established reference points and property monuments, and shall make no changes or relocations without the prior written approval of Owner. Contractor shall report to Engineer whenever any reference point or property monument is lost or destroyed or requires relocation because of necessary changes in grades or locations, and shall be responsible for the accurate replacement or relocation of such reference points or property monuments by professionally qualified personnel.

4.06 Hazardous Environmental Condition at Site

- A. *Reports and Drawings:* The Supplementary Conditions identify those reports and drawings known to Owner relating to Hazardous Environmental Conditions that have been identified at the Site.

- B. *Limited Reliance by Contractor on Technical Data Authorized:* Contractor may rely upon the accuracy of the "technical data" contained in such reports and drawings, but such reports and drawings are not Contract Documents. Such "technical data" is identified in the Supplementary Conditions. Except for such reliance on such "technical data," Contractor may not rely upon or make any claim against Owner or Engineer, or any of their officers, directors, members, partners, employees, agents, consultants, or subcontractors with respect to:

1. the completeness of such reports and drawings for Contractor's purposes, including, but not limited to, any aspects of the means, methods, techniques, sequences and procedures of construction to be employed by Contractor and safety precautions and programs incident thereto; or
2. other data, interpretations, opinions and information contained in such reports or shown or indicated in such drawings; or
3. any Contractor interpretation of or conclusion drawn from any "technical data" or any such other data, interpretations, opinions or information.

- C. Contractor shall not be responsible for any Hazardous Environmental Condition uncovered or revealed at the Site which was not shown or indicated in Drawings or Specifications or identified in the Contract Documents to be within the scope of the Work. Contractor shall be responsible for a Hazardous Environmental Condition created with any materials brought to the Site by Contractor, Subcontractors, Suppliers, or anyone else for whom Contractor is responsible.

- D. If Contractor encounters a Hazardous Environmental Condition or if Contractor or anyone for whom Contractor is responsible creates a Hazardous Environmental Condition, Contractor shall immediately: (i) secure or otherwise isolate such condition; (ii) stop all Work in connection with such condition and in any area affected thereby (except in an emergency as required by Paragraph 6.16.A); and (iii) notify Owner and Engineer (and promptly thereafter confirm such notice in writing). Owner shall promptly consult with Engineer concerning the necessity for Owner to retain a qualified expert to evaluate such condition or take corrective action,

if any. Promptly after consulting with Engineer, Owner shall take such actions as are necessary to permit Owner to timely obtain required permits and provide Contractor the written notice required by Paragraph 4.06.E.

- E. Contractor shall not be required to resume Work in connection with such condition or in any affected area until after Owner has obtained any required permits related thereto and delivered written notice to Contractor: (i) specifying that such condition and any affected area is or has been rendered safe for the resumption of Work; or (ii) specifying any special conditions under which such Work may be resumed safely. If Owner and Contractor cannot agree as to entitlement to or on the amount or extent, if any, of any adjustment in Contract Price or Contract Times, or both, as a result of such Work stoppage or such special conditions under which Work is agreed to be resumed by Contractor, either party may make a Claim therefor as provided in Paragraph 10.05.
- F. If after receipt of such written notice Contractor does not agree to resume such Work based on a reasonable belief it is unsafe, or does not agree to resume such Work under such special conditions, then Owner may order the portion of the Work that is in the area affected by such condition to be deleted from the Work. If Owner and Contractor cannot agree as to entitlement to or on the amount or extent, if any, of an adjustment in Contract Price or Contract Times as a result of deleting such portion of the Work, then either party may make a Claim therefor as provided in Paragraph 10.05. Owner may have such deleted portion of the Work performed by Owner's own forces or others in accordance with Article 7.
- G. To the fullest extent permitted by Laws and Regulations, Owner shall indemnify and hold harmless Contractor, Subcontractors, and Engineer, and the officers, directors, members, partners, employees, agents, consultants, and subcontractors of each and any of them from and against all claims, costs, losses, and damages (including but not limited to all fees and charges of engineers, architects, attorneys, and other professionals and all court or arbitration or other dispute resolution costs) arising out of or relating to a Hazardous Environmental Condition, provided that such Hazardous Environmental Condition: (i) was not shown or indicated in the Drawings or Specifications or identified in the Contract Documents to be included within the scope of the Work, and (ii) was not created by

Contractor or by anyone for whom Contractor is responsible. Nothing in this Paragraph 4.06.G shall obligate Owner to indemnify any individual or entity from and against the consequences of that individual's or entity's own negligence.

- H. To the fullest extent permitted by Laws and Regulations, Contractor shall indemnify and hold harmless Owner and Engineer, and the officers, directors, members, partners, employees, agents, consultants, and subcontractors of each and any of them from and against all claims, costs, losses, and damages (including but not limited to all fees and charges of engineers, architects, attorneys, and other professionals and all court or arbitration or other dispute resolution costs) arising out of or relating to a Hazardous Environmental Condition created by Contractor or by anyone for whom Contractor is responsible. Nothing in this Paragraph 4.06.H shall obligate Contractor to indemnify any individual or entity from and against the consequences of that individual's or entity's own negligence.
- I. The provisions of Paragraphs 4.02, 4.03, and 4.04 do not apply to a Hazardous Environmental Condition uncovered or revealed at the Site.

ARTICLE 5 – BONDS AND INSURANCE

5.01 *Performance, Payment, and Other Bonds*

- A. Contractor shall furnish performance and payment bonds, each in an amount at least equal to the Contract Price as security for the faithful performance and payment of all of Contractor's obligations under the Contract Documents. These bonds shall remain in effect until one year after the date when final payment becomes due or until completion of the correction period specified in Paragraph 13.07, whichever is later, except as provided otherwise by Laws or Regulations or by the Contract Documents. Contractor shall also furnish such other bonds as are required by the Contract Documents.
- B. All bonds shall be in the form prescribed by the Contract Documents except as provided otherwise by Laws or Regulations, and shall be executed by such sureties as are named in the list of "Companies Holding Certificates of Authority as Acceptable Sureties on Federal Bonds and as Acceptable Reinsuring Companies" as published in Circular 570 (amended) by the Financial Management Service, Surety Bond Branch, U.S. Department of the Treasury. All bonds signed by

an agent or attorney-in-fact must be accompanied by a certified copy of that individual's authority to bind the surety. The evidence of authority shall show that it is effective on the date the agent or attorney-in-fact signed each bond.

- C. If the surety on any bond furnished by Contractor is declared bankrupt or becomes insolvent or its right to do business is terminated in any state where any part of the Project is located or it ceases to meet the requirements of Paragraph 5.01.B, Contractor shall promptly notify Owner and Engineer and shall, within 20 days after the event giving rise to such notification, provide another bond and surety, both of which shall comply with the requirements of Paragraphs 5.01.B and 5.02.

5.02 *Licensed Sureties and Insurers*

- A. All bonds and insurance required by the Contract Documents to be purchased and maintained by Owner or Contractor shall be obtained from surety or insurance companies that are duly licensed or authorized in the jurisdiction in which the Project is located to issue bonds or insurance policies for the limits and coverages so required. Such surety and insurance companies shall also meet such additional requirements and qualifications as may be provided in the Supplementary Conditions.

5.03 *Certificates of Insurance*

- A. Contractor shall deliver to Owner, with copies to each additional insured and loss payee identified in the Supplementary Conditions, certificates of insurance (and other evidence of insurance requested by Owner or any other additional insured) which Contractor is required to purchase and maintain.
- B. Owner shall deliver to Contractor, with copies to each additional insured and loss payee identified in the Supplementary Conditions, certificates of insurance (and other evidence of insurance requested by Contractor or any other additional insured) which Owner is required to purchase and maintain.
- C. Failure of Owner to demand such certificates or other evidence of Contractor's full compliance with these insurance requirements or failure of Owner to identify a deficiency in compliance from the evidence provided shall not be construed as a waiver of Contractor's obligation to maintain such insurance.

- D. Owner does not represent that insurance coverage and limits established in this Contract necessarily will be adequate to protect Contractor.

- E. The insurance and insurance limits required herein shall not be deemed as a limitation on Contractor's liability under the indemnities granted to Owner in the Contract Documents.

5.04 *Contractor's Insurance*

- A. Contractor shall purchase and maintain such insurance as is appropriate for the Work being performed and as will provide protection from claims set forth below which may arise out of or result from Contractor's performance of the Work and Contractor's other obligations under the Contract Documents, whether it is to be performed by Contractor, any Subcontractor or Supplier, or by anyone directly or indirectly employed by any of them to perform any of the Work, or by anyone for whose acts any of them may be liable:

1. claims under workers' compensation, disability benefits, and other similar employee benefit acts;
2. claims for damages because of bodily injury, occupational sickness or disease, or death of Contractor's employees;
3. claims for damages because of bodily injury, sickness or disease, or death of any person other than Contractor's employees;
4. claims for damages insured by reasonably available personal injury liability coverage which are sustained:
 - a. by any person as a result of an offense directly or indirectly related to the employment of such person by Contractor, or
 - b. by any other person for any other reason;
5. claims for damages, other than to the Work itself, because of injury to or destruction of tangible property wherever located, including loss of use resulting therefrom; and
6. claims for damages because of bodily injury or death of any person or property damage arising out of the ownership, maintenance or use of any motor vehicle.

B. The policies of insurance required by this Paragraph 5.04 shall:

1. with respect to insurance required by Paragraphs 5.04.A.3 through 5.04.A.6 inclusive, be written on an occurrence basis, include as additional insureds (subject to any customary exclusion regarding professional liability) Owner and Engineer, and any other individuals or entities identified in the Supplementary Conditions, all of whom shall be listed as additional insureds, and include coverage for the respective officers, directors, members, partners, employees, agents, consultants, and subcontractors of each and any of all such additional insureds, and the insurance afforded to these additional insureds shall provide primary coverage for all claims covered thereby;
2. include at least the specific coverages and be written for not less than the limits of liability provided in the Supplementary Conditions or required by Laws or Regulations, whichever is greater;
3. include contractual liability insurance covering Contractor's indemnity obligations under Paragraphs 6.11 and 6.20;
4. contain a provision or endorsement that the coverage afforded will not be canceled, materially changed or renewal refused until at least 30 days prior written notice has been given to Owner and Contractor and to each other additional insured identified in the Supplementary Conditions to whom a certificate of insurance has been issued (and the certificates of insurance furnished by the Contractor pursuant to Paragraph 5.03 will so provide);
5. remain in effect at least until final payment and at all times thereafter when Contractor may be correcting, removing, or replacing defective Work in accordance with Paragraph 13.07; and
6. include completed operations coverage:
 - a. Such insurance shall remain in effect for two years after final payment.
 - b. Contractor shall furnish Owner and each other additional insured identified in the Supplementary Conditions, to whom a

certificate of insurance has been issued, evidence satisfactory to Owner and any such additional insured of continuation of such insurance at final payment and one year thereafter.

5.05 *Owner's Liability Insurance*

- A. In addition to the insurance required to be provided by Contractor under Paragraph 5.04, Owner, at Owner's option, may purchase and maintain at Owner's expense Owner's own liability insurance as will protect Owner against claims which may arise from operations under the Contract Documents.

5.06 *Property Insurance*

- A. Unless otherwise provided in the Supplementary Conditions, Owner shall purchase and maintain property insurance upon the Work at the Site in the amount of the full replacement cost thereof (subject to such deductible amounts as may be provided in the Supplementary Conditions or required by Laws and Regulations). This insurance shall:

1. include the interests of Owner, Contractor, Subcontractors, and Engineer, and any other individuals or entities identified in the Supplementary Conditions, and the officers, directors, members, partners, employees, agents, consultants, and subcontractors of each and any of them, each of whom is deemed to have an insurable interest and shall be listed as a loss payee;
2. be written on a Builder's Risk "all-risk" policy form that shall at least include insurance for physical loss or damage to the Work, temporary buildings, falsework, and materials and equipment in transit, and shall insure against at least the following perils or causes of loss: fire, lightning, extended coverage, theft, vandalism and malicious mischief, earthquake, collapse, debris removal, demolition occasioned by enforcement of Laws and Regulations, water damage (other than that caused by flood), and such other perils or causes of loss as may be specifically required by the Supplementary Conditions.
3. include expenses incurred in the repair or replacement of any insured property

(including but not limited to fees and charges of engineers and architects);

4. cover materials and equipment stored at the Site or at another location that was agreed to in writing by Owner prior to being incorporated in the Work, provided that such materials and equipment have been included in an Application for Payment recommended by Engineer;
 5. allow for partial utilization of the Work by Owner;
 6. include testing and startup; and
 7. be maintained in effect until final payment is made unless otherwise agreed to in writing by Owner, Contractor, and Engineer with 30 days written notice to each other loss payee to whom a certificate of insurance has been issued.
- B. Owner shall purchase and maintain such equipment breakdown insurance or additional property insurance as may be required by the Supplementary Conditions or Laws and Regulations which will include the interests of Owner, Contractor, Subcontractors, and Engineer, and any other individuals or entities identified in the Supplementary Conditions, and the officers, directors, members, partners, employees, agents, consultants and subcontractors of each and any of them, each of whom is deemed to have an insurable interest and shall be listed as a loss payee.
- C. All the policies of insurance (and the certificates or other evidence thereof) required to be purchased and maintained in accordance with this Paragraph 5.06 will contain a provision or endorsement that the coverage afforded will not be canceled or materially changed or renewal refused until at least 30 days prior written notice has been given to Owner and Contractor and to each other loss payee to whom a certificate of insurance has been issued and will contain waiver provisions in accordance with Paragraph 5.07.
- D. Owner shall not be responsible for purchasing and maintaining any property insurance specified in this Paragraph 5.06 to protect the interests of Contractor, Subcontractors, or others in the Work to the extent of any deductible amounts that are identified in the Supplementary Conditions. The risk of loss within such identified deductible

amount will be borne by Contractor, Subcontractors, or others suffering any such loss, and if any of them wishes property insurance coverage within the limits of such amounts, each may purchase and maintain it at the purchaser's own expense.

- E. If Contractor requests in writing that other special insurance be included in the property insurance policies provided under this Paragraph 5.06, Owner shall, if possible, include such insurance, and the cost thereof will be charged to Contractor by appropriate Change Order. Prior to commencement of the Work at the Site, Owner shall in writing advise Contractor whether or not such other insurance has been procured by Owner.

5.07 *Waiver of Rights*

- A. Owner and Contractor intend that all policies purchased in accordance with Paragraph 5.06 will protect Owner, Contractor, Subcontractors, and Engineer, and all other individuals or entities identified in the Supplementary Conditions as loss payees (and the officers, directors, members, partners, employees, agents, consultants, and subcontractors of each and any of them) in such policies and will provide primary coverage for all losses and damages caused by the perils or causes of loss covered thereby. All such policies shall contain provisions to the effect that in the event of payment of any loss or damage the insurers will have no rights of recovery against any of the insureds or loss payees thereunder. Owner and Contractor waive all rights against each other and their respective officers, directors, members, partners, employees, agents, consultants and subcontractors of each and any of them for all losses and damages caused by, arising out of or resulting from any of the perils or causes of loss covered by such policies and any other property insurance applicable to the Work; and, in addition, waive all such rights against Subcontractors and Engineer, and all other individuals or entities identified in the Supplementary Conditions as loss payees (and the officers, directors, members, partners, employees, agents, consultants, and subcontractors of each and any of them) under such policies for losses and damages so caused. None of the above waivers shall extend to the rights that any party making such waiver may have to the proceeds of insurance held by Owner as trustee or otherwise payable under any policy so issued.

B. Owner waives all rights against Contractor, Subcontractors, and Engineer, and the officers, directors, members, partners, employees, agents, consultants and subcontractors of each and any of them for:

1. loss due to business interruption, loss of use, or other consequential loss extending beyond direct physical loss or damage to Owner's property or the Work caused by, arising out of, or resulting from fire or other perils whether or not insured by Owner; and
2. loss or damage to the completed Project or part thereof caused by, arising out of, or resulting from fire or other insured peril or cause of loss covered by any property insurance maintained on the completed Project or part thereof by Owner during partial utilization pursuant to Paragraph 14.05, after Substantial Completion pursuant to Paragraph 14.04, or after final payment pursuant to Paragraph 14.07.

C. Any insurance policy maintained by Owner covering any loss, damage or consequential loss referred to in Paragraph 5.07.B shall contain provisions to the effect that in the event of payment of any such loss, damage, or consequential loss, the insurers will have no rights of recovery against Contractor, Subcontractors, or Engineer, and the officers, directors, members, partners, employees, agents, consultants and subcontractors of each and any of them.

5.08 *Receipt and Application of Insurance Proceeds*

- A. Any insured loss under the policies of insurance required by Paragraph 5.06 will be adjusted with Owner and made payable to Owner as fiduciary for the loss payees, as their interests may appear, subject to the requirements of any applicable mortgage clause and of Paragraph 5.08.B. Owner shall deposit in a separate account any money so received and shall distribute it in accordance with such agreement as the parties in interest may reach. If no other special agreement is reached, the damaged Work shall be repaired or replaced, the moneys so received applied on account thereof, and the Work and the cost thereof covered by an appropriate Change Order.
- B. Owner as fiduciary shall have power to adjust and settle any loss with the insurers unless one of the parties in interest shall object in writing within 15 days after the occurrence of loss to Owner's

exercise of this power. If such objection be made, Owner as fiduciary shall make settlement with the insurers in accordance with such agreement as the parties in interest may reach. If no such agreement among the parties in interest is reached, Owner as fiduciary shall adjust and settle the loss with the insurers and, if required in writing by any party in interest, Owner as fiduciary shall give bond for the proper performance of such duties.

5.09 *Acceptance of Bonds and Insurance; Option to Replace*

- A. If either Owner or Contractor has any objection to the coverage afforded by or other provisions of the bonds or insurance required to be purchased and maintained by the other party in accordance with Article 5 on the basis of non-conformance with the Contract Documents, the objecting party shall so notify the other party in writing within 10 days after receipt of the certificates (or other evidence requested) required by Paragraph 2.01.B. Owner and Contractor shall each provide to the other such additional information in respect of insurance provided as the other may reasonably request. If either party does not purchase or maintain all of the bonds and insurance required of such party by the Contract Documents, such party shall notify the other party in writing of such failure to purchase prior to the start of the Work, or of such failure to maintain prior to any change in the required coverage. Without prejudice to any other right or remedy, the other party may elect to obtain equivalent bonds or insurance to protect such other party's interests at the expense of the party who was required to provide such coverage, and a Change Order shall be issued to adjust the Contract Price accordingly.

5.10 *Partial Utilization, Acknowledgment of Property Insurer*

- A. If Owner finds it necessary to occupy or use a portion or portions of the Work prior to Substantial Completion of all the Work as provided in Paragraph 14.05, no such use or occupancy shall commence before the insurers providing the property insurance pursuant to Paragraph 5.06 have acknowledged notice thereof and in writing effected any changes in coverage necessitated thereby. The insurers providing the property insurance shall consent by endorsement on the policy or policies, but the property insurance shall not be canceled or permitted to lapse on account of any such partial use or occupancy.

ARTICLE 6 -- CONTRACTOR'S RESPONSIBILITIES

6.01 *Supervision and Superintendence*

- A. Contractor shall supervise, inspect, and direct the Work competently and efficiently, devoting such attention thereto and applying such skills and expertise as may be necessary to perform the Work in accordance with the Contract Documents. Contractor shall be solely responsible for the means, methods, techniques, sequences, and procedures of construction. Contractor shall not be responsible for the negligence of Owner or Engineer in the design or specification of a specific means, method, technique, sequence, or procedure of construction which is shown or indicated in and expressly required by the Contract Documents.
- B. At all times during the progress of the Work, Contractor shall assign a competent resident superintendent who shall not be replaced without written notice to Owner and Engineer except under extraordinary circumstances.

6.02 *Labor; Working Hours*

- A. Contractor shall provide competent, suitably qualified personnel to survey and lay out the Work and perform construction as required by the Contract Documents. Contractor shall at all times maintain good discipline and order at the Site.
- B. Except as otherwise required for the safety or protection of persons or the Work or property at the Site or adjacent thereto, and except as otherwise stated in the Contract Documents, all Work at the Site shall be performed during regular working hours. Contractor will not permit the performance of Work on a Saturday, Sunday, or any legal holiday without Owner's written consent (which will not be unreasonably withheld) given after prior written notice to Engineer.

6.03 *Services, Materials, and Equipment*

- A. Unless otherwise specified in the Contract Documents, Contractor shall provide and assume full responsibility for all services, materials, equipment, labor, transportation, construction equipment and machinery, tools, appliances, fuel, power, light, heat, telephone, water, sanitary facilities, temporary facilities, and all other facilities and incidentals necessary for the performance, testing, start-up, and completion of the Work.

- B. All materials and equipment incorporated into the Work shall be as specified or, if not specified, shall be of good quality and new, except as otherwise provided in the Contract Documents. All special warranties and guarantees required by the Specifications shall expressly run to the benefit of Owner. If required by Engineer, Contractor shall furnish satisfactory evidence (including reports of required tests) as to the source, kind, and quality of materials and equipment.
- C. All materials and equipment shall be stored, applied, installed, connected, erected, protected, used, cleaned, and conditioned in accordance with instructions of the applicable Supplier, except as otherwise may be provided in the Contract Documents.

6.04 *Progress Schedule*

- A. Contractor shall adhere to the Progress Schedule established in accordance with Paragraph 2.07 as it may be adjusted from time to time as provided below.
 - 1. Contractor shall submit to Engineer for acceptance (to the extent indicated in Paragraph 2.07) proposed adjustments in the Progress Schedule that will not result in changing the Contract Times. Such adjustments will comply with any provisions of the General Requirements applicable thereto.
 - 2. Proposed adjustments in the Progress Schedule that will change the Contract Times shall be submitted in accordance with the requirements of Article 12. Adjustments in Contract Times may only be made by a Change Order.

6.05 *Substitutes and "Or-Equals"*

- A. Whenever an item of material or equipment is specified or described in the Contract Documents by using the name of a proprietary item or the name of a particular Supplier, the specification or description is intended to establish the type, function, appearance, and quality required. Unless the specification or description contains or is followed by words reading that no like, equivalent, or "or-equal" item or no substitution is permitted, other items of material or equipment or material or equipment of other Suppliers may be

submitted to Engineer for review under the circumstances described below.

1. *"Or-Equal" Items:* If in Engineer's sole discretion an item of material or equipment proposed by Contractor is functionally equal to that named and sufficiently similar so that no change in related Work will be required, it may be considered by Engineer as an "or-equal" item, in which case review and approval of the proposed item may, in Engineer's sole discretion, be accomplished without compliance with some or all of the requirements for approval of proposed substitute items. For the purposes of this Paragraph 6.05.A.1, a proposed item of material or equipment will be considered functionally equal to an item so named if:

a. in the exercise of reasonable judgment Engineer determines that:

- 1) it is at least equal in materials of construction, quality, durability, appearance, strength, and design characteristics;
- 2) it will reliably perform at least equally well the function and achieve the results imposed by the design concept of the completed Project as a functioning whole; and
- 3) it has a proven record of performance and availability of responsive service.

b. Contractor certifies that, if approved and incorporated into the Work:

- 1) there will be no increase in cost to the Owner or increase in Contract Times; and
- 2) it will conform substantially to the detailed requirements of the item named in the Contract Documents.

2. *Substitute Items:*

a. If in Engineer's sole discretion an item of material or equipment proposed by Contractor does not qualify as an "or-equal" item under Paragraph 6.05.A.1, it will be considered a proposed substitute item.

b. Contractor shall submit sufficient information as provided below to allow Engineer to determine if the item of material or equipment proposed is essentially equivalent to that named and an acceptable substitute therefor. Requests for review of proposed substitute items of material or equipment will not be accepted by Engineer from anyone other than Contractor.

c. The requirements for review by Engineer will be as set forth in Paragraph 6.05.A.2.d, as supplemented by the General Requirements, and as Engineer may decide is appropriate under the circumstances.

d. Contractor shall make written application to Engineer for review of a proposed substitute item of material or equipment that Contractor seeks to furnish or use. The application:

1) shall certify that the proposed substitute item will:

- a) perform adequately the functions and achieve the results called for by the general design,
- b) be similar in substance to that specified, and
- c) be suited to the same use as that specified;

2) will state:

- a) the extent, if any, to which the use of the proposed substitute item will prejudice Contractor's achievement of Substantial Completion on time,
- b) whether use of the proposed substitute item in the Work will require a change in any of the Contract Documents (or in the provisions of any other direct contract with Owner for other work on the Project) to adapt the design to the proposed substitute item, and

- c) whether incorporation or use of the proposed substitute item in connection with the Work is subject to payment of any license fee or royalty;

3) will identify:

- a) all variations of the proposed substitute item from that specified, and
- b) available engineering, sales, maintenance, repair, and replacement services; and

4) shall contain an itemized estimate of all costs or credits that will result directly or indirectly from use of such substitute item, including costs of redesign and claims of other contractors affected by any resulting change.

B. Substitute Construction Methods or Procedures:

If a specific means, method, technique, sequence, or procedure of construction is expressly required by the Contract Documents, Contractor may furnish or utilize a substitute means, method, technique, sequence, or procedure of construction approved by Engineer. Contractor shall submit sufficient information to allow Engineer, in Engineer's sole discretion, to determine that the substitute proposed is equivalent to that expressly called for by the Contract Documents. The requirements for review by Engineer will be similar to those provided in Paragraph 6.05.A.2.

C. Engineer's Evaluation: Engineer will be allowed a reasonable time within which to evaluate each proposal or submittal made pursuant to Paragraphs 6.05.A and 6.05.B. Engineer may require Contractor to furnish additional data about the proposed substitute item. Engineer will be the sole judge of acceptability. No "or equal" or substitute will be ordered, installed or utilized until Engineer's review is complete, which will be evidenced by a Change Order in the case of a substitute and an approved Shop Drawing for an "or equal." Engineer will advise Contractor in writing of any negative determination.

D. Special Guarantee: Owner may require Contractor to furnish at Contractor's expense a special performance guarantee or other surety with respect to any substitute.

E. Engineer's Cost Reimbursement: Engineer will record Engineer's costs in evaluating a substitute proposed or submitted by Contractor pursuant to Paragraphs 6.05.A.2 and 6.05.B. Whether or not Engineer approves a substitute so proposed or submitted by Contractor, Contractor shall reimburse Owner for the reasonable charges of Engineer for evaluating each such proposed substitute. Contractor shall also reimburse Owner for the reasonable charges of Engineer for making changes in the Contract Documents (or in the provisions of any other direct contract with Owner) resulting from the acceptance of each proposed substitute.

F. Contractor's Expense: Contractor shall provide all data in support of any proposed substitute or "or-equal" at Contractor's expense.

6.06 Concerning Subcontractors, Suppliers, and Others

A. Contractor shall not employ any Subcontractor, Supplier, or other individual or entity (including those acceptable to Owner as indicated in Paragraph 6.06.B), whether initially or as a replacement, against whom Owner may have reasonable objection. Contractor shall not be required to employ any Subcontractor, Supplier, or other individual or entity to furnish or perform any of the Work against whom Contractor has reasonable objection.

B. If the Supplementary Conditions require the identity of certain Subcontractors, Suppliers, or other individuals or entities to be submitted to Owner in advance for acceptance by Owner by a specified date prior to the Effective Date of the Agreement, and if Contractor has submitted a list thereof in accordance with the Supplementary Conditions, Owner's acceptance (either in writing or by failing to make written objection thereto by the date indicated for acceptance or objection in the Bidding Documents or the Contract Documents) of any such Subcontractor, Supplier, or other individual or entity so identified may be revoked on the basis of reasonable objection after due investigation. Contractor shall submit an acceptable replacement for the rejected Subcontractor, Supplier, or other individual or entity, and the Contract Price will be adjusted by the difference in the cost occasioned by such replacement, and an appropriate Change Order will be issued. No acceptance by Owner of any such Subcontractor, Supplier, or other individual or entity, whether initially or as a replacement,

shall constitute a waiver of any right of Owner or Engineer to reject defective Work.

C. Contractor shall be fully responsible to Owner and Engineer for all acts and omissions of the Subcontractors, Suppliers, and other individuals or entities performing or furnishing any of the Work just as Contractor is responsible for Contractor's own acts and omissions. Nothing in the Contract Documents:

1. shall create for the benefit of any such Subcontractor, Supplier, or other individual or entity any contractual relationship between Owner or Engineer and any such Subcontractor, Supplier or other individual or entity; nor
2. shall create any obligation on the part of Owner or Engineer to pay or to see to the payment of any moneys due any such Subcontractor, Supplier, or other individual or entity except as may otherwise be required by Laws and Regulations.

D. Contractor shall be solely responsible for scheduling and coordinating the Work of Subcontractors, Suppliers, and other individuals or entities performing or furnishing any of the Work under a direct or indirect contract with Contractor.

E. Contractor shall require all Subcontractors, Suppliers, and such other individuals or entities performing or furnishing any of the Work to communicate with Engineer through Contractor.

F. The divisions and sections of the Specifications and the identifications of any Drawings shall not control Contractor in dividing the Work among Subcontractors or Suppliers or delineating the Work to be performed by any specific trade.

G. All Work performed for Contractor by a Subcontractor or Supplier will be pursuant to an appropriate agreement between Contractor and the Subcontractor or Supplier which specifically binds the Subcontractor or Supplier to the applicable terms and conditions of the Contract Documents for the benefit of Owner and Engineer. Whenever any such agreement is with a Subcontractor or Supplier who is listed as a loss payee on the property insurance provided in Paragraph 5.06, the agreement between the Contractor and the Subcontractor or Supplier will contain provisions whereby the Subcontractor or Supplier waives all rights against Owner, Contractor, Engineer, and

all other individuals or entities identified in the Supplementary Conditions to be listed as insureds or loss payees (and the officers, directors, members, partners, employees, agents, consultants, and subcontractors of each and any of them) for all losses and damages caused by, arising out of, relating to, or resulting from any of the perils or causes of loss covered by such policies and any other property insurance applicable to the Work. If the insurers on any such policies require separate waiver forms to be signed by any Subcontractor or Supplier, Contractor will obtain the same.

6.07 *Patent Fees and Royalties*

A. Contractor shall pay all license fees and royalties and assume all costs incident to the use in the performance of the Work or the incorporation in the Work of any invention, design, process, product, or device which is the subject of patent rights or copyrights held by others. If a particular invention, design, process, product, or device is specified in the Contract Documents for use in the performance of the Work and if, to the actual knowledge of Owner or Engineer, its use is subject to patent rights or copyrights calling for the payment of any license fee or royalty to others, the existence of such rights shall be disclosed by Owner in the Contract Documents.

B. To the fullest extent permitted by Laws and Regulations, Owner shall indemnify and hold harmless Contractor, and its officers, directors, members, partners, employees, agents, consultants, and subcontractors from and against all claims, costs, losses, and damages (including but not limited to all fees and charges of engineers, architects, attorneys, and other professionals, and all court or arbitration or other dispute resolution costs) arising out of or relating to any infringement of patent rights or copyrights incident to the use in the performance of the Work or resulting from the incorporation in the Work of any invention, design, process, product, or device specified in the Contract Documents, but not identified as being subject to payment of any license fee or royalty to others required by patent rights or copyrights.

C. To the fullest extent permitted by Laws and Regulations, Contractor shall indemnify and hold harmless Owner and Engineer, and the officers, directors, members, partners, employees, agents, consultants and subcontractors of each and any of them from and against all claims, costs, losses,

and damages (including but not limited to all fees and charges of engineers, architects, attorneys, and other professionals and all court or arbitration or other dispute resolution costs) arising out of or relating to any infringement of patent rights or copyrights incident to the use in the performance of the Work or resulting from the incorporation in the Work of any invention, design, process, product, or device not specified in the Contract Documents.

6.08 *Permits*

- A. Unless otherwise provided in the Supplementary Conditions, Contractor shall obtain and pay for all construction permits and licenses. Owner shall assist Contractor, when necessary, in obtaining such permits and licenses. Contractor shall pay all governmental charges and inspection fees necessary for the prosecution of the Work which are applicable at the time of opening of Bids, or, if there are no Bids, on the Effective Date of the Agreement. Owner shall pay all charges of utility owners for connections for providing permanent service to the Work.

6.09 *Laws and Regulations*

- A. Contractor shall give all notices required by and shall comply with all Laws and Regulations applicable to the performance of the Work. Except where otherwise expressly required by applicable Laws and Regulations, neither Owner nor Engineer shall be responsible for monitoring Contractor's compliance with any Laws or Regulations.
- B. If Contractor performs any Work knowing or having reason to know that it is contrary to Laws or Regulations, Contractor shall bear all claims, costs, losses, and damages (including but not limited to all fees and charges of engineers, architects, attorneys, and other professionals and all court or arbitration or other dispute resolution costs) arising out of or relating to such Work. However, it shall not be Contractor's responsibility to make certain that the Specifications and Drawings are in accordance with Laws and Regulations, but this shall not relieve Contractor of Contractor's obligations under Paragraph 3.03.
- C. Changes in Laws or Regulations not known at the time of opening of Bids (or, on the Effective Date of the Agreement if there were no Bids) having an effect on the cost or time of performance of the

Work shall be the subject of an adjustment in Contract Price or Contract Times. If Owner and Contractor are unable to agree on entitlement to or on the amount or extent, if any, of any such adjustment, a Claim may be made therefor as provided in Paragraph 10.05.

6.10 *Taxes*

- A. Contractor shall pay all sales, consumer, use, and other similar taxes required to be paid by Contractor in accordance with the Laws and Regulations of the place of the Project which are applicable during the performance of the Work.

6.11 *Use of Site and Other Areas*

A. *Limitation on Use of Site and Other Areas:*

1. Contractor shall confine construction equipment, the storage of materials and equipment, and the operations of workers to the Site and other areas permitted by Laws and Regulations, and shall not unreasonably encumber the Site and other areas with construction equipment or other materials or equipment. Contractor shall assume full responsibility for any damage to any such land or area, or to the owner or occupant thereof, or of any adjacent land or areas resulting from the performance of the Work.
2. Should any claim be made by any such owner or occupant because of the performance of the Work, Contractor shall promptly settle with such other party by negotiation or otherwise resolve the claim by arbitration or other dispute resolution proceeding or at law.
3. To the fullest extent permitted by Laws and Regulations, Contractor shall indemnify and hold harmless Owner and Engineer, and the officers, directors, members, partners, employees, agents, consultants and subcontractors of each and any of them from and against all claims, costs, losses, and damages (including but not limited to all fees and charges of engineers, architects, attorneys, and other professionals and all court or arbitration or other dispute resolution costs) arising out of or relating to any claim or action, legal or equitable, brought by any such owner or occupant against Owner, Engineer, or any other party indemnified hereunder to the extent caused by or based upon Contractor's performance of the Work.

B. *Removal of Debris During Performance of the Work:* During the progress of the Work Contractor shall keep the Site and other areas free from accumulations of waste materials, rubbish, and other debris. Removal and disposal of such waste materials, rubbish, and other debris shall conform to applicable Laws and Regulations.

C. *Cleaning:* Prior to Substantial Completion of the Work Contractor shall clean the Site and the Work and make it ready for utilization by Owner. At the completion of the Work Contractor shall remove from the Site all tools, appliances, construction equipment and machinery, and surplus materials and shall restore to original condition all property not designated for alteration by the Contract Documents.

D. *Loading Structures:* Contractor shall not load nor permit any part of any structure to be loaded in any manner that will endanger the structure, nor shall Contractor subject any part of the Work or adjacent property to stresses or pressures that will endanger it.

6.12 *Record Documents*

A. Contractor shall maintain in a safe place at the Site one record copy of all Drawings, Specifications, Addenda, Change Orders, Work Change Directives, Field Orders, and written interpretations and clarifications in good order and annotated to show changes made during construction. These record documents together with all approved Samples and a counterpart of all approved Shop Drawings will be available to Engineer for reference. Upon completion of the Work, these record documents, Samples, and Shop Drawings will be delivered to Engineer for Owner.

6.13 *Safety and Protection*

A. Contractor shall be solely responsible for initiating, maintaining and supervising all safety precautions and programs in connection with the Work. Such responsibility does not relieve Subcontractors of their responsibility for the safety of persons or property in the performance of their work, nor for compliance with applicable safety Laws and Regulations. Contractor shall take all necessary precautions for the safety of, and shall provide the necessary protection to prevent damage, injury or loss to:

1. all persons on the Site or who may be affected by the Work;
2. all the Work and materials and equipment to be incorporated therein, whether in storage on or off the Site; and
3. other property at the Site or adjacent thereto, including trees, shrubs, lawns, walks, pavements, roadways, structures, utilities, and Underground Facilities not designated for removal, relocation, or replacement in the course of construction.

B. Contractor shall comply with all applicable Laws and Regulations relating to the safety of persons or property, or to the protection of persons or property from damage, injury, or loss; and shall erect and maintain all necessary safeguards for such safety and protection. Contractor shall notify owners of adjacent property and of Underground Facilities and other utility owners when prosecution of the Work may affect them, and shall cooperate with them in the protection, removal, relocation, and replacement of their property.

C. Contractor shall comply with the applicable requirements of Owner's safety programs, if any. The Supplementary Conditions identify any Owner's safety programs that are applicable to the Work.

D. Contractor shall inform Owner and Engineer of the specific requirements of Contractor's safety program with which Owner's and Engineer's employees and representatives must comply while at the Site.

E. All damage, injury, or loss to any property referred to in Paragraph 6.13.A.2 or 6.13.A.3 caused, directly or indirectly, in whole or in part, by Contractor, any Subcontractor, Supplier, or any other individual or entity directly or indirectly employed by any of them to perform any of the Work, or anyone for whose acts any of them may be liable, shall be remedied by Contractor (except damage or loss attributable to the fault of Drawings or Specifications or to the acts or omissions of Owner or Engineer or anyone employed by any of them, or anyone for whose acts any of them may be liable, and not attributable, directly or indirectly, in whole or in part, to the fault or negligence of Contractor or any Subcontractor, Supplier, or other individual or

entity directly or indirectly employed by any of them).

- F. Contractor's duties and responsibilities for safety and for protection of the Work shall continue until such time as all the Work is completed and Engineer has issued a notice to Owner and Contractor in accordance with Paragraph 14.07.B that the Work is acceptable (except as otherwise expressly provided in connection with Substantial Completion).

6.14 *Safety Representative*

- A. Contractor shall designate a qualified and experienced safety representative at the Site whose duties and responsibilities shall be the prevention of accidents and the maintaining and supervising of safety precautions and programs.

6.15 *Hazard Communication Programs*

- A. Contractor shall be responsible for coordinating any exchange of material safety data sheets or other hazard communication information required to be made available to or exchanged between or among employers at the Site in accordance with Laws or Regulations.

6.16 *Emergencies*

- A. In emergencies affecting the safety or protection of persons or the Work or property at the Site or adjacent thereto, Contractor is obligated to act to prevent threatened damage, injury, or loss. Contractor shall give Engineer prompt written notice if Contractor believes that any significant changes in the Work or variations from the Contract Documents have been caused thereby or are required as a result thereof. If Engineer determines that a change in the Contract Documents is required because of the action taken by Contractor in response to such an emergency, a Work Change Directive or Change Order will be issued.

6.17 *Shop Drawings and Samples*

- A. Contractor shall submit Shop Drawings and Samples to Engineer for review and approval in accordance with the accepted Schedule of Submittals (as required by Paragraph 2.07). Each submittal will be identified as Engineer may require.

1. *Shop Drawings:*

- a. Submit number of copies specified in the General Requirements.
- b. Data shown on the Shop Drawings will be complete with respect to quantities, dimensions, specified performance and design criteria, materials, and similar data to show Engineer the services, materials, and equipment Contractor proposes to provide and to enable Engineer to review the information for the limited purposes required by Paragraph 6.17.D.

2. *Samples:*

- a. Submit number of Samples specified in the Specifications.
- b. Clearly identify each Sample as to material, Supplier, pertinent data such as catalog numbers, the use for which intended and other data as Engineer may require to enable Engineer to review the submittal for the limited purposes required by Paragraph 6.17.D.

- B. Where a Shop Drawing or Sample is required by the Contract Documents or the Schedule of Submittals, any related Work performed prior to Engineer's review and approval of the pertinent submittal will be at the sole expense and responsibility of Contractor.

C. *Submittal Procedures:*

- 1. Before submitting each Shop Drawing or Sample, Contractor shall have:
 - a. reviewed and coordinated each Shop Drawing or Sample with other Shop Drawings and Samples and with the requirements of the Work and the Contract Documents;
 - b. determined and verified all field measurements, quantities, dimensions, specified performance and design criteria, installation requirements, materials, catalog numbers, and similar information with respect thereto;
 - c. determined and verified the suitability of all materials offered with respect to the

indicated application, fabrication, shipping, handling, storage, assembly, and installation pertaining to the performance of the Work; and

d. determined and verified all information relative to Contractor's responsibilities for means, methods, techniques, sequences, and procedures of construction, and safety precautions and programs incident thereto.

2. Each submittal shall bear a stamp or specific written certification that Contractor has satisfied Contractor's obligations under the Contract Documents with respect to Contractor's review and approval of that submittal.

3. With each submittal, Contractor shall give Engineer specific written notice of any variations that the Shop Drawing or Sample may have from the requirements of the Contract Documents. This notice shall be both a written communication separate from the Shop Drawings or Sample submittal; and, in addition, by a specific notation made on each Shop Drawing or Sample submitted to Engineer for review and approval of each such variation.

D. Engineer's Review:

1. Engineer will provide timely review of Shop Drawings and Samples in accordance with the Schedule of Submittals acceptable to Engineer. Engineer's review and approval will be only to determine if the items covered by the submittals will, after installation or incorporation in the Work, conform to the information given in the Contract Documents and be compatible with the design concept of the completed Project as a functioning whole as indicated by the Contract Documents.

2. Engineer's review and approval will not extend to means, methods, techniques, sequences, or procedures of construction (except where a particular means, method, technique, sequence, or procedure of construction is specifically and expressly called for by the Contract Documents) or to safety precautions or programs incident thereto. The review and approval of a separate item as such will not indicate

approval of the assembly in which the item functions.

3. Engineer's review and approval shall not relieve Contractor from responsibility for any variation from the requirements of the Contract Documents unless Contractor has complied with the requirements of Paragraph 6.17.C.3 and Engineer has given written approval of each such variation by specific written notation thereof incorporated in or accompanying the Shop Drawing or Sample. Engineer's review and approval shall not relieve Contractor from responsibility for complying with the requirements of Paragraph 6.17.C.1.

E. Resubmittal Procedures:

1. Contractor shall make corrections required by Engineer and shall return the required number of corrected copies of Shop Drawings and submit, as required, new Samples for review and approval. Contractor shall direct specific attention in writing to revisions other than the corrections called for by Engineer on previous submittals.

6.18 *Continuing the Work*

A. Contractor shall carry on the Work and adhere to the Progress Schedule during all disputes or disagreements with Owner. No Work shall be delayed or postponed pending resolution of any disputes or disagreements, except as permitted by Paragraph 15.04 or as Owner and Contractor may otherwise agree in writing.

6.19 *Contractor's General Warranty and Guarantee*

A. Contractor warrants and guarantees to Owner that all Work will be in accordance with the Contract Documents and will not be defective. Engineer and its officers, directors, members, partners, employees, agents, consultants, and subcontractors shall be entitled to rely on representation of Contractor's warranty and guarantee.

B. Contractor's warranty and guarantee hereunder excludes defects or damage caused by:

1. abuse, modification, or improper maintenance or operation by persons other than Contractor, Subcontractors, Suppliers, or any other

individual or entity for whom Contractor is responsible; or

2. normal wear and tear under normal usage.

C. Contractor's obligation to perform and complete the Work in accordance with the Contract Documents shall be absolute. None of the following will constitute an acceptance of Work that is not in accordance with the Contract Documents or a release of Contractor's obligation to perform the Work in accordance with the Contract Documents:

1. observations by Engineer;
2. recommendation by Engineer or payment by Owner of any progress or final payment;
3. the issuance of a certificate of Substantial Completion by Engineer or any payment related thereto by Owner;
4. use or occupancy of the Work or any part thereof by Owner;
5. any review and approval of a Shop Drawing or Sample submittal or the issuance of a notice of acceptability by Engineer;
6. any inspection, test, or approval by others; or
7. any correction of defective Work by Owner.

6.20 Indemnification

A. To the fullest extent permitted by Laws and Regulations, Contractor shall indemnify and hold harmless Owner and Engineer, and the officers, directors, members, partners, employees, agents, consultants and subcontractors of each and any of them from and against all claims, costs, losses, and damages (including but not limited to all fees and charges of engineers, architects, attorneys, and other professionals and all court or arbitration or other dispute resolution costs) arising out of or relating to the performance of the Work, provided that any such claim, cost, loss, or damage is attributable to bodily injury, sickness, disease, or death, or to injury to or destruction of tangible property (other than the Work itself), including the loss of use resulting therefrom but only to the extent caused by any negligent act or omission of Contractor, any Subcontractor, any Supplier, or any individual or entity directly or indirectly employed by any of them to perform any of the

Work or anyone for whose acts any of them may be liable.

B. In any and all claims against Owner or Engineer or any of their officers, directors, members, partners, employees, agents, consultants, or subcontractors by any employee (or the survivor or personal representative of such employee) of Contractor, any Subcontractor, any Supplier, or any individual or entity directly or indirectly employed by any of them to perform any of the Work, or anyone for whose acts any of them may be liable, the indemnification obligation under Paragraph 6.20.A shall not be limited in any way by any limitation on the amount or type of damages, compensation, or benefits payable by or for Contractor or any such Subcontractor, Supplier, or other individual or entity under workers' compensation acts, disability benefit acts, or other employee benefit acts.

C. The indemnification obligations of Contractor under Paragraph 6.20.A shall not extend to the liability of Engineer and Engineer's officers, directors, members, partners, employees, agents, consultants and subcontractors arising out of:

1. the preparation or approval of, or the failure to prepare or approve maps, Drawings, opinions, reports, surveys, Change Orders, designs, or Specifications; or
2. giving directions or instructions, or failing to give them, if that is the primary cause of the injury or damage.

6.21 Delegation of Professional Design Services

A. Contractor will not be required to provide professional design services unless such services are specifically required by the Contract Documents for a portion of the Work or unless such services are required to carry out Contractor's responsibilities for construction means, methods, techniques, sequences and procedures. Contractor shall not be required to provide professional services in violation of applicable law.

B. If professional design services or certifications by a design professional related to systems, materials or equipment are specifically required of Contractor by the Contract Documents, Owner and Engineer will specify all performance and design criteria that such services must satisfy. Contractor shall cause such services or

certifications to be provided by a properly licensed professional, whose signature and seal shall appear on all drawings, calculations, specifications, certifications, Shop Drawings and other submittals prepared by such professional. Shop Drawings and other submittals related to the Work designed or certified by such professional, if prepared by others, shall bear such professional's written approval when submitted to Engineer.

- C. Owner and Engineer shall be entitled to rely upon the adequacy, accuracy and completeness of the services, certifications or approvals performed by such design professionals, provided Owner and Engineer have specified to Contractor all performance and design criteria that such services must satisfy.
- D. Pursuant to this Paragraph 6.21, Engineer's review and approval of design calculations and design drawings will be only for the limited purpose of checking for conformance with performance and design criteria given and the design concept expressed in the Contract Documents. Engineer's review and approval of Shop Drawings and other submittals (except design calculations and design drawings) will be only for the purpose stated in Paragraph 6.17.D.1.
- E. Contractor shall not be responsible for the adequacy of the performance or design criteria required by the Contract Documents.

ARTICLE 7 – OTHER WORK AT THE SITE

7.01 *Related Work at Site*

- A. Owner may perform other work related to the Project at the Site with Owner's employees, or through other direct contracts therefor, or have other work performed by utility owners. If such other work is not noted in the Contract Documents, then:
 - 1. written notice thereof will be given to Contractor prior to starting any such other work; and
 - 2. if Owner and Contractor are unable to agree on entitlement to or on the amount or extent, if any, of any adjustment in the Contract Price or Contract Times that should be allowed as a result of such other work, a Claim may be made therefor as provided in Paragraph 10.05.

B. Contractor shall afford each other contractor who is a party to such a direct contract, each utility owner, and Owner, if Owner is performing other work with Owner's employees, proper and safe access to the Site, provide a reasonable opportunity for the introduction and storage of materials and equipment and the execution of such other work, and properly coordinate the Work with theirs. Contractor shall do all cutting, fitting, and patching of the Work that may be required to properly connect or otherwise make its several parts come together and properly integrate with such other work. Contractor shall not endanger any work of others by cutting, excavating, or otherwise altering such work; provided, however, that Contractor may cut or alter others' work with the written consent of Engineer and the others whose work will be affected. The duties and responsibilities of Contractor under this Paragraph are for the benefit of such utility owners and other contractors to the extent that there are comparable provisions for the benefit of Contractor in said direct contracts between Owner and such utility owners and other contractors.

C. If the proper execution or results of any part of Contractor's Work depends upon work performed by others under this Article 7, Contractor shall inspect such other work and promptly report to Engineer in writing any delays, defects, or deficiencies in such other work that render it unavailable or unsuitable for the proper execution and results of Contractor's Work. Contractor's failure to so report will constitute an acceptance of such other work as fit and proper for integration with Contractor's Work except for latent defects and deficiencies in such other work.

7.02 *Coordination*

- A. If Owner intends to contract with others for the performance of other work on the Project at the Site, the following will be set forth in Supplementary Conditions:
 - 1. the individual or entity who will have authority and responsibility for coordination of the activities among the various contractors will be identified;
 - 2. the specific matters to be covered by such authority and responsibility will be itemized; and
 - 3. the extent of such authority and responsibilities will be provided.

- B. Unless otherwise provided in the Supplementary Conditions, Owner shall have sole authority and responsibility for such coordination.

Contractor copies of reports of explorations and tests of subsurface conditions and drawings of physical conditions relating to existing surface or subsurface structures at the Site.

7.03 *Legal Relationships*

- A. Paragraphs 7.01.A and 7.02 are not applicable for utilities not under the control of Owner.
- B. Each other direct contract of Owner under Paragraph 7.01.A shall provide that the other contractor is liable to Owner and Contractor for the reasonable direct delay and disruption costs incurred by Contractor as a result of the other contractor's wrongful actions or inactions.
- C. Contractor shall be liable to Owner and any other contractor under direct contract to Owner for the reasonable direct delay and disruption costs incurred by such other contractor as a result of Contractor's wrongful action or inactions.

8.06 *Insurance*

- A. Owner's responsibilities, if any, with respect to purchasing and maintaining liability and property insurance are set forth in Article 5.

8.07 *Change Orders*

- A. Owner is obligated to execute Change Orders as indicated in Paragraph 10.03.

8.08 *Inspections, Tests, and Approvals*

- A. Owner's responsibility with respect to certain inspections, tests, and approvals is set forth in Paragraph 13.03.B.

ARTICLE 8 – OWNER'S RESPONSIBILITIES

8.09 *Limitations on Owner's Responsibilities*

8.01 *Communications to Contractor*

- A. Except as otherwise provided in these General Conditions, Owner shall issue all communications to Contractor through Engineer.

- A. The Owner shall not supervise, direct, or have control or authority over, nor be responsible for, Contractor's means, methods, techniques, sequences, or procedures of construction, or the safety precautions and programs incident thereto, or for any failure of Contractor to comply with Laws and Regulations applicable to the performance of the Work. Owner will not be responsible for Contractor's failure to perform the Work in accordance with the Contract Documents.

8.02 *Replacement of Engineer*

- A. In case of termination of the employment of Engineer, Owner shall appoint an engineer to whom Contractor makes no reasonable objection, whose status under the Contract Documents shall be that of the former Engineer.

8.10 *Undisclosed Hazardous Environmental Condition*

- A. Owner's responsibility in respect to an undisclosed Hazardous Environmental Condition is set forth in Paragraph 4.06.

8.03 *Furnish Data*

- A. Owner shall promptly furnish the data required of Owner under the Contract Documents.

8.11 *Evidence of Financial Arrangements*

- A. Upon request of Contractor, Owner shall furnish Contractor reasonable evidence that financial arrangements have been made to satisfy Owner's obligations under the Contract Documents.

8.04 *Pay When Due*

- A. Owner shall make payments to Contractor when they are due as provided in Paragraphs 14.02.C and 14.07.C.

8.05 *Lands and Easements; Reports and Tests*

- A. Owner's duties with respect to providing lands and easements and providing engineering surveys to establish reference points are set forth in Paragraphs 4.01 and 4.05. Paragraph 4.02 refers to Owner's identifying and making available to

8.12 *Compliance with Safety Program*

- A. While at the Site, Owner's employees and representatives shall comply with the specific applicable requirements of Contractor's safety programs of which Owner has been informed pursuant to Paragraph 6.13.D.

ARTICLE 9 – ENGINEER’S STATUS DURING CONSTRUCTION

9.01 *Owner’s Representative*

- A. Engineer will be Owner’s representative during the construction period. The duties and responsibilities and the limitations of authority of Engineer as Owner’s representative during construction are set forth in the Contract Documents.

9.02 *Visits to Site*

- A. Engineer will make visits to the Site at intervals appropriate to the various stages of construction as Engineer deems necessary in order to observe as an experienced and qualified design professional the progress that has been made and the quality of the various aspects of Contractor’s executed Work. Based on information obtained during such visits and observations, Engineer, for the benefit of Owner, will determine, in general, if the Work is proceeding in accordance with the Contract Documents. Engineer will not be required to make exhaustive or continuous inspections on the Site to check the quality or quantity of the Work. Engineer’s efforts will be directed toward providing for Owner a greater degree of confidence that the completed Work will conform generally to the Contract Documents. On the basis of such visits and observations, Engineer will keep Owner informed of the progress of the Work and will endeavor to guard Owner against defective Work.
- B. Engineer’s visits and observations are subject to all the limitations on Engineer’s authority and responsibility set forth in Paragraph 9.09. Particularly, but without limitation, during or as a result of Engineer’s visits or observations of Contractor’s Work, Engineer will not supervise, direct, control, or have authority over or be responsible for Contractor’s means, methods, techniques, sequences, or procedures of construction, or the safety precautions and programs incident thereto, or for any failure of Contractor to comply with Laws and Regulations applicable to the performance of the Work.

9.03 *Project Representative*

- A. If Owner and Engineer agree, Engineer will furnish a Resident Project Representative to assist Engineer in providing more extensive observation of the Work. The authority and responsibilities of

any such Resident Project Representative and assistants will be as provided in the Supplementary Conditions, and limitations on the responsibilities thereof will be as provided in Paragraph 9.09. If Owner designates another representative or agent to represent Owner at the Site who is not Engineer’s consultant, agent or employee, the responsibilities and authority and limitations thereon of such other individual or entity will be as provided in the Supplementary Conditions.

9.04 *Authorized Variations in Work*

- A. Engineer may authorize minor variations in the Work from the requirements of the Contract Documents which do not involve an adjustment in the Contract Price or the Contract Times and are compatible with the design concept of the completed Project as a functioning whole as indicated by the Contract Documents. These may be accomplished by a Field Order and will be binding on Owner and also on Contractor, who shall perform the Work involved promptly. If Owner or Contractor believes that a Field Order justifies an adjustment in the Contract Price or Contract Times, or both, and the parties are unable to agree on entitlement to or on the amount or extent, if any, of any such adjustment, a Claim may be made therefor as provided in Paragraph 10.05.

9.05 *Rejecting Defective Work*

- A. Engineer will have authority to reject Work which Engineer believes to be defective, or that Engineer believes will not produce a completed Project that conforms to the Contract Documents or that will prejudice the integrity of the design concept of the completed Project as a functioning whole as indicated by the Contract Documents. Engineer will also have authority to require special inspection or testing of the Work as provided in Paragraph 13.04, whether or not the Work is fabricated, installed, or completed.

9.06 *Shop Drawings, Change Orders and Payments*

- A. In connection with Engineer’s authority, and limitations thereof, as to Shop Drawings and Samples, see Paragraph 6.17.
- B. In connection with Engineer’s authority, and limitations thereof, as to design calculations and design drawings submitted in response to a

delegation of professional design services, if any, see Paragraph 6.21.

- C. In connection with Engineer's authority as to Change Orders, see Articles 10, 11, and 12.
- D. In connection with Engineer's authority as to Applications for Payment, see Article 14.

9.07 *Determinations for Unit Price Work*

- A. Engineer will determine the actual quantities and classifications of Unit Price Work performed by Contractor. Engineer will review with Contractor the Engineer's preliminary determinations on such matters before rendering a written decision thereon (by recommendation of an Application for Payment or otherwise). Engineer's written decision thereon will be final and binding (except as modified by Engineer to reflect changed factual conditions or more accurate data) upon Owner and Contractor, subject to the provisions of Paragraph 10.05.

9.08 *Decisions on Requirements of Contract Documents and Acceptability of Work*

- A. Engineer will be the initial interpreter of the requirements of the Contract Documents and judge of the acceptability of the Work thereunder. All matters in question and other matters between Owner and Contractor arising prior to the date final payment is due relating to the acceptability of the Work, and the interpretation of the requirements of the Contract Documents pertaining to the performance of the Work, will be referred initially to Engineer in writing within 30 days of the event giving rise to the question.
- B. Engineer will, with reasonable promptness, render a written decision on the issue referred. If Owner or Contractor believes that any such decision entitles them to an adjustment in the Contract Price or Contract Times or both, a Claim may be made under Paragraph 10.05. The date of Engineer's decision shall be the date of the event giving rise to the issues referenced for the purposes of Paragraph 10.05.B.
- C. Engineer's written decision on the issue referred will be final and binding on Owner and Contractor, subject to the provisions of Paragraph 10.05.
- D. When functioning as interpreter and judge under this Paragraph 9.08, Engineer will not show

partiality to Owner or Contractor and will not be liable in connection with any interpretation or decision rendered in good faith in such capacity.

9.09 *Limitations on Engineer's Authority and Responsibilities*

- A. Neither Engineer's authority or responsibility under this Article 9 or under any other provision of the Contract Documents nor any decision made by Engineer in good faith either to exercise or not exercise such authority or responsibility or the undertaking, exercise, or performance of any authority or responsibility by Engineer shall create, impose, or give rise to any duty in contract, tort, or otherwise owed by Engineer to Contractor, any Subcontractor, any Supplier, any other individual or entity, or to any surety for or employee or agent of any of them.
- B. Engineer will not supervise, direct, control, or have authority over or be responsible for Contractor's means, methods, techniques, sequences, or procedures of construction, or the safety precautions and programs incident thereto, or for any failure of Contractor to comply with Laws and Regulations applicable to the performance of the Work. Engineer will not be responsible for Contractor's failure to perform the Work in accordance with the Contract Documents.
- C. Engineer will not be responsible for the acts or omissions of Contractor or of any Subcontractor, any Supplier, or of any other individual or entity performing any of the Work.
- D. Engineer's review of the final Application for Payment and accompanying documentation and all maintenance and operating instructions, schedules, guarantees, bonds, certificates of inspection, tests and approvals, and other documentation required to be delivered by Paragraph 14.07.A will only be to determine generally that their content complies with the requirements of, and in the case of certificates of inspections, tests, and approvals that the results certified indicate compliance with, the Contract Documents.
- E. The limitations upon authority and responsibility set forth in this Paragraph 9.09 shall also apply to the Resident Project Representative, if any, and assistants, if any.

9.10 *Compliance with Safety Program*

- A. While at the Site, Engineer's employees and representatives shall comply with the specific applicable requirements of Contractor's safety programs of which Engineer has been informed pursuant to Paragraph 6.13.D.

ARTICLE 10 – CHANGES IN THE WORK; CLAIMS

10.01 *Authorized Changes in the Work*

- A. Without invalidating the Contract and without notice to any surety, Owner may, at any time or from time to time, order additions, deletions, or revisions in the Work by a Change Order, or a Work Change Directive. Upon receipt of any such document, Contractor shall promptly proceed with the Work involved which will be performed under the applicable conditions of the Contract Documents (except as otherwise specifically provided).
- B. If Owner and Contractor are unable to agree on entitlement to, or on the amount or extent, if any, of an adjustment in the Contract Price or Contract Times, or both, that should be allowed as a result of a Work Change Directive, a Claim may be made therefor as provided in Paragraph 10.05.

10.02 *Unauthorized Changes in the Work*

- A. Contractor shall not be entitled to an increase in the Contract Price or an extension of the Contract Times with respect to any work performed that is not required by the Contract Documents as amended, modified, or supplemented as provided in Paragraph 3.04, except in the case of an emergency as provided in Paragraph 6.16 or in the case of uncovering Work as provided in Paragraph 13.04.D.

10.03 *Execution of Change Orders*

- A. Owner and Contractor shall execute appropriate Change Orders recommended by Engineer covering:
 - 1. changes in the Work which are: (i) ordered by Owner pursuant to Paragraph 10.01.A, (ii) required because of acceptance of defective Work under Paragraph 13.08.A or Owner's correction of defective Work under Paragraph 13.09, or (iii) agreed to by the parties;

- 2. changes in the Contract Price or Contract Times which are agreed to by the parties, including any undisputed sum or amount of time for Work actually performed in accordance with a Work Change Directive; and

- 3. changes in the Contract Price or Contract Times which embody the substance of any written decision rendered by Engineer pursuant to Paragraph 10.05; provided that, in lieu of executing any such Change Order, an appeal may be taken from any such decision in accordance with the provisions of the Contract Documents and applicable Laws and Regulations, but during any such appeal, Contractor shall carry on the Work and adhere to the Progress Schedule as provided in Paragraph 6.18.A.

10.04 *Notification to Surety*

- A. If the provisions of any bond require notice to be given to a surety of any change affecting the general scope of the Work or the provisions of the Contract Documents (including, but not limited to, Contract Price or Contract Times), the giving of any such notice will be Contractor's responsibility. The amount of each applicable bond will be adjusted to reflect the effect of any such change.

10.05 *Claims*

- A. *Engineer's Decision Required:* All Claims, except those waived pursuant to Paragraph 14.09, shall be referred to the Engineer for decision. A decision by Engineer shall be required as a condition precedent to any exercise by Owner or Contractor of any rights or remedies either may otherwise have under the Contract Documents or by Laws and Regulations in respect of such Claims.

- B. *Notice:* Written notice stating the general nature of each Claim shall be delivered by the claimant to Engineer and the other party to the Contract promptly (but in no event later than 30 days) after the start of the event giving rise thereto. The responsibility to substantiate a Claim shall rest with the party making the Claim. Notice of the amount or extent of the Claim, with supporting data shall be delivered to the Engineer and the other party to the Contract within 60 days after the start of such event (unless Engineer allows additional time for claimant to submit additional

or more accurate data in support of such Claim). A Claim for an adjustment in Contract Price shall be prepared in accordance with the provisions of Paragraph 12.01.B. A Claim for an adjustment in Contract Times shall be prepared in accordance with the provisions of Paragraph 12.02.B. Each Claim shall be accompanied by claimant's written statement that the adjustment claimed is the entire adjustment to which the claimant believes it is entitled as a result of said event. The opposing party shall submit any response to Engineer and the claimant within 30 days after receipt of the claimant's last submittal (unless Engineer allows additional time).

C. *Engineer's Action:* Engineer will review each Claim and, within 30 days after receipt of the last submittal of the claimant or the last submittal of the opposing party, if any, take one of the following actions in writing:

1. deny the Claim in whole or in part;
2. approve the Claim; or
3. notify the parties that the Engineer is unable to resolve the Claim if, in the Engineer's sole discretion, it would be inappropriate for the Engineer to do so. For purposes of further resolution of the Claim, such notice shall be deemed a denial.

D. In the event that Engineer does not take action on a Claim within said 30 days, the Claim shall be deemed denied.

E. Engineer's written action under Paragraph 10.05.C or denial pursuant to Paragraphs 10.05.C.3 or 10.05.D will be final and binding upon Owner and Contractor, unless Owner or Contractor invoke the dispute resolution procedure set forth in Article 16 within 30 days of such action or denial.

F. No Claim for an adjustment in Contract Price or Contract Times will be valid if not submitted in accordance with this Paragraph 10.05.

ARTICLE 11 – COST OF THE WORK; ALLOWANCES; UNIT PRICE WORK

11.01 *Cost of the Work*

A. *Costs Included:* The term Cost of the Work means the sum of all costs, except those excluded in Paragraph 11.01.B, necessarily incurred and

paid by Contractor in the proper performance of the Work. When the value of any Work covered by a Change Order or when a Claim for an adjustment in Contract Price is determined on the basis of Cost of the Work, the costs to be reimbursed to Contractor will be only those additional or incremental costs required because of the change in the Work or because of the event giving rise to the Claim. Except as otherwise may be agreed to in writing by Owner, such costs shall be in amounts no higher than those prevailing in the locality of the Project, shall not include any of the costs itemized in Paragraph 11.01.B, and shall include only the following items:

1. Payroll costs for employees in the direct employ of Contractor in the performance of the Work under schedules of job classifications agreed upon by Owner and Contractor. Such employees shall include, without limitation, superintendents, foremen, and other personnel employed full time on the Work. Payroll costs for employees not employed full time on the Work shall be apportioned on the basis of their time spent on the Work. Payroll costs shall include, but not be limited to, salaries and wages plus the cost of fringe benefits, which shall include social security contributions, unemployment, excise, and payroll taxes, workers' compensation, health and retirement benefits, bonuses, sick leave, vacation and holiday pay applicable thereto. The expenses of performing Work outside of regular working hours, on Saturday, Sunday, or legal holidays, shall be included in the above to the extent authorized by Owner.

2. Cost of all materials and equipment furnished and incorporated in the Work, including costs of transportation and storage thereof, and Suppliers' field services required in connection therewith. All cash discounts shall accrue to Contractor unless Owner deposits funds with Contractor with which to make payments, in which case the cash discounts shall accrue to Owner. All trade discounts, rebates and refunds and returns from sale of surplus materials and equipment shall accrue to Owner, and Contractor shall make provisions so that they may be obtained.

3. Payments made by Contractor to Subcontractors for Work performed by Subcontractors. If required by Owner, Contractor shall obtain competitive bids from

subcontractors acceptable to Owner and Contractor and shall deliver such bids to Owner, who will then determine, with the advice of Engineer, which bids, if any, will be acceptable. If any subcontract provides that the Subcontractor is to be paid on the basis of Cost of the Work plus a fee, the Subcontractor's Cost of the Work and fee shall be determined in the same manner as Contractor's Cost of the Work and fee as provided in this Paragraph 11.01.

4. Costs of special consultants (including but not limited to engineers, architects, testing laboratories, surveyors, attorneys, and accountants) employed for services specifically related to the Work.

5. Supplemental costs including the following:

a. The proportion of necessary transportation, travel, and subsistence expenses of Contractor's employees incurred in discharge of duties connected with the Work.

b. Cost, including transportation and maintenance, of all materials, supplies, equipment, machinery, appliances, office, and temporary facilities at the Site, and hand tools not owned by the workers, which are consumed in the performance of the Work, and cost, less market value, of such items used but not consumed which remain the property of Contractor.

c. Rentals of all construction equipment and machinery, and the parts thereof whether rented from Contractor or others in accordance with rental agreements approved by Owner with the advice of Engineer, and the costs of transportation, loading, unloading, assembly, dismantling, and removal thereof. All such costs shall be in accordance with the terms of said rental agreements. The rental of any such equipment, machinery, or parts shall cease when the use thereof is no longer necessary for the Work.

d. Sales, consumer, use, and other similar taxes related to the Work, and for which Contractor is liable, as imposed by Laws and Regulations.

e. Deposits lost for causes other than negligence of Contractor, any Subcontractor, or anyone directly or indirectly employed by any of them or for whose acts any of them may be liable, and royalty payments and fees for permits and licenses.

f. Losses and damages (and related expenses) caused by damage to the Work, not compensated by insurance or otherwise, sustained by Contractor in connection with the performance of the Work (except losses and damages within the deductible amounts of property insurance established in accordance with Paragraph 5.06.D), provided such losses and damages have resulted from causes other than the negligence of Contractor, any Subcontractor, or anyone directly or indirectly employed by any of them or for whose acts any of them may be liable. Such losses shall include settlements made with the written consent and approval of Owner. No such losses, damages, and expenses shall be included in the Cost of the Work for the purpose of determining Contractor's fee.

g. The cost of utilities, fuel, and sanitary facilities at the Site.

h. Minor expenses such as telegrams, long distance telephone calls, telephone service at the Site, express and courier services, and similar petty cash items in connection with the Work.

i. The costs of premiums for all bonds and insurance Contractor is required by the Contract Documents to purchase and maintain.

B. *Costs Excluded:* The term Cost of the Work shall not include any of the following items:

1. Payroll costs and other compensation of Contractor's officers, executives, principals (of partnerships and sole proprietorships), general managers, safety managers, engineers, architects, estimators, attorneys, auditors, accountants, purchasing and contracting agents, expeditors, timekeepers, clerks, and other personnel employed by Contractor, whether at the Site or in Contractor's principal or branch office for

general administration of the Work and not specifically included in the agreed upon schedule of job classifications referred to in Paragraph 11.01.A.1 or specifically covered by Paragraph 11.01.A.4, all of which are to be considered administrative costs covered by the Contractor's fee.

2. Expenses of Contractor's principal and branch offices other than Contractor's office at the Site.
3. Any part of Contractor's capital expenses, including interest on Contractor's capital employed for the Work and charges against Contractor for delinquent payments.
4. Costs due to the negligence of Contractor, any Subcontractor, or anyone directly or indirectly employed by any of them or for whose acts any of them may be liable, including but not limited to, the correction of defective Work, disposal of materials or equipment wrongly supplied, and making good any damage to property.
5. Other overhead or general expense costs of any kind and the costs of any item not specifically and expressly included in Paragraphs 11.01.A.

C. *Contractor's Fee:* When all the Work is performed on the basis of cost-plus, Contractor's fee shall be determined as set forth in the Agreement. When the value of any Work covered by a Change Order or when a Claim for an adjustment in Contract Price is determined on the basis of Cost of the Work, Contractor's fee shall be determined as set forth in Paragraph 12.01.C.

D. *Documentation:* Whenever the Cost of the Work for any purpose is to be determined pursuant to Paragraphs 11.01.A and 11.01.B, Contractor will establish and maintain records thereof in accordance with generally accepted accounting practices and submit in a form acceptable to Engineer an itemized cost breakdown together with supporting data.

11.02 Allowances

A. It is understood that Contractor has included in the Contract Price all allowances so named in the Contract Documents and shall cause the Work so covered to be performed for such sums and by

such persons or entities as may be acceptable to Owner and Engineer.

B. *Cash Allowances:*

1. Contractor agrees that:

- a. the cash allowances include the cost to Contractor (less any applicable trade discounts) of materials and equipment required by the allowances to be delivered at the Site, and all applicable taxes; and
- b. Contractor's costs for unloading and handling on the Site, labor, installation, overhead, profit, and other expenses contemplated for the cash allowances have been included in the Contract Price and not in the allowances, and no demand for additional payment on account of any of the foregoing will be valid.

C. *Contingency Allowance:*

1. Contractor agrees that a contingency allowance, if any, is for the sole use of Owner to cover unanticipated costs.

D. Prior to final payment, an appropriate Change Order will be issued as recommended by Engineer to reflect actual amounts due Contractor on account of Work covered by allowances, and the Contract Price shall be correspondingly adjusted.

11.03 Unit Price Work

A. Where the Contract Documents provide that all or part of the Work is to be Unit Price Work, initially the Contract Price will be deemed to include for all Unit Price Work an amount equal to the sum of the unit price for each separately identified item of Unit Price Work times the estimated quantity of each item as indicated in the Agreement.

B. The estimated quantities of items of Unit Price Work are not guaranteed and are solely for the purpose of comparison of Bids and determining an initial Contract Price. Determinations of the actual quantities and classifications of Unit Price Work performed by Contractor will be made by Engineer subject to the provisions of Paragraph 9.07.

- C. Each unit price will be deemed to include an amount considered by Contractor to be adequate to cover Contractor's overhead and profit for each separately identified item.
- D. Owner or Contractor may make a Claim for an adjustment in the Contract Price in accordance with Paragraph 10.05 if:
 - 1. the quantity of any item of Unit Price Work performed by Contractor differs materially and significantly from the estimated quantity of such item indicated in the Agreement; and
 - 2. there is no corresponding adjustment with respect to any other item of Work; and
 - 3. Contractor believes that Contractor is entitled to an increase in Contract Price as a result of having incurred additional expense or Owner believes that Owner is entitled to a decrease in Contract Price and the parties are unable to agree as to the amount of any such increase or decrease.

- 3. where the Work involved is not covered by unit prices contained in the Contract Documents and agreement to a lump sum is not reached under Paragraph 12.01.B.2, on the basis of the Cost of the Work (determined as provided in Paragraph 11.01) plus a Contractor's fee for overhead and profit (determined as provided in Paragraph 12.01.C).

C. *Contractor's Fee:* The Contractor's fee for overhead and profit shall be determined as follows:

- 1. a mutually acceptable fixed fee; or
- 2. if a fixed fee is not agreed upon, then a fee based on the following percentages of the various portions of the Cost of the Work:
 - a. for costs incurred under Paragraphs 11.01.A.1 and 11.01.A.2, the Contractor's fee shall be 15 percent;
 - b. for costs incurred under Paragraph 11.01.A.3, the Contractor's fee shall be five percent;
 - c. where one or more tiers of subcontracts are on the basis of Cost of the Work plus a fee and no fixed fee is agreed upon, the intent of Paragraphs 12.01.C.2.a and 12.01.C.2.b is that the Subcontractor who actually performs the Work, at whatever tier, will be paid a fee of 15 percent of the costs incurred by such Subcontractor under Paragraphs 11.01.A.1 and 11.01.A.2 and that any higher tier Subcontractor and Contractor will each be paid a fee of five percent of the amount paid to the next lower tier Subcontractor;
 - d. no fee shall be payable on the basis of costs itemized under Paragraphs 11.01.A.4, 11.01.A.5, and 11.01.B;
 - e. the amount of credit to be allowed by Contractor to Owner for any change which results in a net decrease in cost will be the amount of the actual net decrease in cost plus a deduction in Contractor's fee by an amount equal to five percent of such net decrease; and

**ARTICLE 12 – CHANGE OF CONTRACT PRICE;
CHANGE OF CONTRACT TIMES**

12.01 *Change of Contract Price*

- A. The Contract Price may only be changed by a Change Order. Any Claim for an adjustment in the Contract Price shall be based on written notice submitted by the party making the Claim to the Engineer and the other party to the Contract in accordance with the provisions of Paragraph 10.05.
- B. The value of any Work covered by a Change Order or of any Claim for an adjustment in the Contract Price will be determined as follows:
 - 1. where the Work involved is covered by unit prices contained in the Contract Documents, by application of such unit prices to the quantities of the items involved (subject to the provisions of Paragraph 11.03); or
 - 2. where the Work involved is not covered by unit prices contained in the Contract Documents, by a mutually agreed lump sum (which may include an allowance for overhead and profit not necessarily in accordance with Paragraph 12.01.C.2); or

- f. when both additions and credits are involved in any one change, the adjustment in Contractor's fee shall be computed on the basis of the net change in accordance with Paragraphs 12.01.C.2.a through 12.01.C.2.e, inclusive.

12.02 *Change of Contract Times*

- A. The Contract Times may only be changed by a Change Order. Any Claim for an adjustment in the Contract Times shall be based on written notice submitted by the party making the Claim to the Engineer and the other party to the Contract in accordance with the provisions of Paragraph 10.05.
- B. Any adjustment of the Contract Times covered by a Change Order or any Claim for an adjustment in the Contract Times will be determined in accordance with the provisions of this Article 12.

12.03 *Delays*

- A. Where Contractor is prevented from completing any part of the Work within the Contract Times due to delay beyond the control of Contractor, the Contract Times will be extended in an amount equal to the time lost due to such delay if a Claim is made therefor as provided in Paragraph 12.02.A. Delays beyond the control of Contractor shall include, but not be limited to, acts or neglect by Owner, acts or neglect of utility owners or other contractors performing other work as contemplated by Article 7, fires, floods, epidemics, abnormal weather conditions, or acts of God.
- B. If Owner, Engineer, or other contractors or utility owners performing other work for Owner as contemplated by Article 7, or anyone for whom Owner is responsible, delays, disrupts, or interferes with the performance or progress of the Work, then Contractor shall be entitled to an equitable adjustment in the Contract Price or the Contract Times, or both. Contractor's entitlement to an adjustment of the Contract Times is conditioned on such adjustment being essential to Contractor's ability to complete the Work within the Contract Times.
- C. If Contractor is delayed in the performance or progress of the Work by fire, flood, epidemic, abnormal weather conditions, acts of God, acts or failures to act of utility owners not under the

control of Owner, or other causes not the fault of and beyond control of Owner and Contractor, then Contractor shall be entitled to an equitable adjustment in Contract Times, if such adjustment is essential to Contractor's ability to complete the Work within the Contract Times. Such an adjustment shall be Contractor's sole and exclusive remedy for the delays described in this Paragraph 12.03.C.

- D. Owner, Engineer, and their officers, directors, members, partners, employees, agents, consultants, or subcontractors shall not be liable to Contractor for any claims, costs, losses, or damages (including but not limited to all fees and charges of engineers, architects, attorneys, and other professionals and all court or arbitration or other dispute resolution costs) sustained by Contractor on or in connection with any other project or anticipated project.
- E. Contractor shall not be entitled to an adjustment in Contract Price or Contract Times for delays within the control of Contractor. Delays attributable to and within the control of a Subcontractor or Supplier shall be deemed to be delays within the control of Contractor.

ARTICLE 13 – TESTS AND INSPECTIONS; CORRECTION, REMOVAL OR ACCEPTANCE OF DEFECTIVE WORK

13.01 *Notice of Defects*

- A. Prompt notice of all defective Work of which Owner or Engineer has actual knowledge will be given to Contractor. Defective Work may be rejected, corrected, or accepted as provided in this Article 13.

13.02 *Access to Work*

- A. Owner, Engineer, their consultants and other representatives and personnel of Owner, independent testing laboratories, and governmental agencies with jurisdictional interests will have access to the Site and the Work at reasonable times for their observation, inspection, and testing. Contractor shall provide them proper and safe conditions for such access and advise them of Contractor's safety procedures and programs so that they may comply therewith as applicable.

13.03 *Tests and Inspections*

- A. Contractor shall give Engineer timely notice of readiness of the Work for all required inspections, tests, or approvals and shall cooperate with inspection and testing personnel to facilitate required inspections or tests.
- B. Owner shall employ and pay for the services of an independent testing laboratory to perform all inspections, tests, or approvals required by the Contract Documents except:
 - 1. for inspections, tests, or approvals covered by Paragraphs 13.03.C and 13.03.D below;
 - 2. that costs incurred in connection with tests or inspections conducted pursuant to Paragraph 13.04.B shall be paid as provided in Paragraph 13.04.C; and
 - 3. as otherwise specifically provided in the Contract Documents.
- C. If Laws or Regulations of any public body having jurisdiction require any Work (or part thereof) specifically to be inspected, tested, or approved by an employee or other representative of such public body, Contractor shall assume full responsibility for arranging and obtaining such inspections, tests, or approvals, pay all costs in connection therewith, and furnish Engineer the required certificates of inspection or approval.
- D. Contractor shall be responsible for arranging and obtaining and shall pay all costs in connection with any inspections, tests, or approvals required for Owner's and Engineer's acceptance of materials or equipment to be incorporated in the Work; or acceptance of materials, mix designs, or equipment submitted for approval prior to Contractor's purchase thereof for incorporation in the Work. Such inspections, tests, or approvals shall be performed by organizations acceptable to Owner and Engineer.
- E. If any Work (or the work of others) that is to be inspected, tested, or approved is covered by Contractor without written concurrence of Engineer, Contractor shall, if requested by Engineer, uncover such Work for observation.
- F. Uncovering Work as provided in Paragraph 13.03.E shall be at Contractor's expense unless Contractor has given Engineer timely notice of Contractor's intention to cover the same and

Engineer has not acted with reasonable promptness in response to such notice.

13.04 *Uncovering Work*

- A. If any Work is covered contrary to the written request of Engineer, it must, if requested by Engineer, be uncovered for Engineer's observation and replaced at Contractor's expense.
- B. If Engineer considers it necessary or advisable that covered Work be observed by Engineer or inspected or tested by others, Contractor, at Engineer's request, shall uncover, expose, or otherwise make available for observation, inspection, or testing as Engineer may require, that portion of the Work in question, furnishing all necessary labor, material, and equipment.
- C. If it is found that the uncovered Work is defective, Contractor shall pay all claims, costs, losses, and damages (including but not limited to all fees and charges of engineers, architects, attorneys, and other professionals and all court or arbitration or other dispute resolution costs) arising out of or relating to such uncovering, exposure, observation, inspection, and testing, and of satisfactory replacement or reconstruction (including but not limited to all costs of repair or replacement of work of others); and Owner shall be entitled to an appropriate decrease in the Contract Price. If the parties are unable to agree as to the amount thereof, Owner may make a Claim therefor as provided in Paragraph 10.05.
- D. If the uncovered Work is not found to be defective, Contractor shall be allowed an increase in the Contract Price or an extension of the Contract Times, or both, directly attributable to such uncovering, exposure, observation, inspection, testing, replacement, and reconstruction. If the parties are unable to agree as to the amount or extent thereof, Contractor may make a Claim therefor as provided in Paragraph 10.05.

13.05 *Owner May Stop the Work*

- A. If the Work is defective, or Contractor fails to supply sufficient skilled workers or suitable materials or equipment, or fails to perform the Work in such a way that the completed Work will conform to the Contract Documents, Owner may order Contractor to stop the Work, or any portion thereof, until the cause for such order has been eliminated; however, this right of Owner to stop

the Work shall not give rise to any duty on the part of Owner to exercise this right for the benefit of Contractor, any Subcontractor, any Supplier, any other individual or entity, or any surety for, or employee or agent of any of them.

13.06 *Correction or Removal of Defective Work*

- A. Promptly after receipt of written notice, Contractor shall correct all defective Work, whether or not fabricated, installed, or completed, or, if the Work has been rejected by Engineer, remove it from the Project and replace it with Work that is not defective. Contractor shall pay all claims, costs, losses, and damages (including but not limited to all fees and charges of engineers, architects, attorneys, and other professionals and all court or arbitration or other dispute resolution costs) arising out of or relating to such correction or removal (including but not limited to all costs of repair or replacement of work of others).
- B. When correcting defective Work under the terms of this Paragraph 13.06 or Paragraph 13.07, Contractor shall take no action that would void or otherwise impair Owner's special warranty and guarantee, if any, on said Work.

13.07 *Correction Period*

- A. If within one year after the date of Substantial Completion (or such longer period of time as may be prescribed by the terms of any applicable special guarantee required by the Contract Documents) or by any specific provision of the Contract Documents, any Work is found to be defective, or if the repair of any damages to the land or areas made available for Contractor's use by Owner or permitted by Laws and Regulations as contemplated in Paragraph 6.11.A is found to be defective, Contractor shall promptly, without cost to Owner and in accordance with Owner's written instructions:
 - 1. repair such defective land or areas; or
 - 2. correct such defective Work; or
 - 3. if the defective Work has been rejected by Owner, remove it from the Project and replace it with Work that is not defective, and
 - 4. satisfactorily correct or repair or remove and replace any damage to other Work, to the work of others or other land or areas resulting therefrom.

B. If Contractor does not promptly comply with the terms of Owner's written instructions, or in an emergency where delay would cause serious risk of loss or damage, Owner may have the defective Work corrected or repaired or may have the rejected Work removed and replaced. All claims, costs, losses, and damages (including but not limited to all fees and charges of engineers, architects, attorneys, and other professionals and all court or arbitration or other dispute resolution costs) arising out of or relating to such correction or repair or such removal and replacement (including but not limited to all costs of repair or replacement of work of others) will be paid by Contractor.

C. In special circumstances where a particular item of equipment is placed in continuous service before Substantial Completion of all the Work, the correction period for that item may start to run from an earlier date if so provided in the Specifications.

D. Where defective Work (and damage to other Work resulting therefrom) has been corrected or removed and replaced under this Paragraph 13.07, the correction period hereunder with respect to such Work will be extended for an additional period of one year after such correction or removal and replacement has been satisfactorily completed.

E. Contractor's obligations under this Paragraph 13.07 are in addition to any other obligation or warranty. The provisions of this Paragraph 13.07 shall not be construed as a substitute for, or a waiver of, the provisions of any applicable statute of limitation or repose.

13.08 *Acceptance of Defective Work*

- A. If, instead of requiring correction or removal and replacement of defective Work, Owner (and, prior to Engineer's recommendation of final payment, Engineer) prefers to accept it, Owner may do so. Contractor shall pay all claims, costs, losses, and damages (including but not limited to all fees and charges of engineers, architects, attorneys, and other professionals and all court or arbitration or other dispute resolution costs) attributable to Owner's evaluation of and determination to accept such defective Work (such costs to be approved by Engineer as to reasonableness) and for the diminished value of the Work to the extent not otherwise paid by Contractor pursuant to this sentence. If any such acceptance occurs prior to

Engineer's recommendation of final payment, a Change Order will be issued incorporating the necessary revisions in the Contract Documents with respect to the Work, and Owner shall be entitled to an appropriate decrease in the Contract Price, reflecting the diminished value of Work so accepted. If the parties are unable to agree as to the amount thereof, Owner may make a Claim therefor as provided in Paragraph 10.05. If the acceptance occurs after such recommendation, an appropriate amount will be paid by Contractor to Owner.

13.09 *Owner May Correct Defective Work*

- A. If Contractor fails within a reasonable time after written notice from Engineer to correct defective Work, or to remove and replace rejected Work as required by Engineer in accordance with Paragraph 13.06.A, or if Contractor fails to perform the Work in accordance with the Contract Documents, or if Contractor fails to comply with any other provision of the Contract Documents, Owner may, after seven days written notice to Contractor, correct, or remedy any such deficiency.
- B. In exercising the rights and remedies under this Paragraph 13.09, Owner shall proceed expeditiously. In connection with such corrective or remedial action, Owner may exclude Contractor from all or part of the Site, take possession of all or part of the Work and suspend Contractor's services related thereto, take possession of Contractor's tools, appliances, construction equipment and machinery at the Site, and incorporate in the Work all materials and equipment stored at the Site or for which Owner has paid Contractor but which are stored elsewhere. Contractor shall allow Owner, Owner's representatives, agents and employees, Owner's other contractors, and Engineer and Engineer's consultants access to the Site to enable Owner to exercise the rights and remedies under this Paragraph.
- C. All claims, costs, losses, and damages (including but not limited to all fees and charges of engineers, architects, attorneys, and other professionals and all court or arbitration or other dispute resolution costs) incurred or sustained by Owner in exercising the rights and remedies under this Paragraph 13.09 will be charged against Contractor, and a Change Order will be issued incorporating the necessary revisions in the Contract Documents with respect to the Work;

and Owner shall be entitled to an appropriate decrease in the Contract Price. If the parties are unable to agree as to the amount of the adjustment, Owner may make a Claim therefor as provided in Paragraph 10.05. Such claims, costs, losses and damages will include but not be limited to all costs of repair, or replacement of work of others destroyed or damaged by correction, removal, or replacement of Contractor's defective Work.

- D. Contractor shall not be allowed an extension of the Contract Times because of any delay in the performance of the Work attributable to the exercise by Owner of Owner's rights and remedies under this Paragraph 13.09.

ARTICLE 14 – PAYMENTS TO CONTRACTOR AND COMPLETION

14.01 *Schedule of Values*

- A. The Schedule of Values established as provided in Paragraph 2.07.A will serve as the basis for progress payments and will be incorporated into a form of Application for Payment acceptable to Engineer. Progress payments on account of Unit Price Work will be based on the number of units completed.

14.02 *Progress Payments*

A. *Applications for Payments:*

- 1. At least 20 days before the date established in the Agreement for each progress payment (but not more often than once a month), Contractor shall submit to Engineer for review an Application for Payment filled out and signed by Contractor covering the Work completed as of the date of the Application and accompanied by such supporting documentation as is required by the Contract Documents. If payment is requested on the basis of materials and equipment not incorporated in the Work but delivered and suitably stored at the Site or at another location agreed to in writing, the Application for Payment shall also be accompanied by a bill of sale, invoice, or other documentation warranting that Owner has received the materials and equipment free and clear of all Liens and evidence that the materials and equipment are covered by appropriate property insurance or other arrangements to

protect Owner's interest therein, all of which must be satisfactory to Owner.

2. Beginning with the second Application for Payment, each Application shall include an affidavit of Contractor stating that all previous progress payments received on account of the Work have been applied on account to discharge Contractor's legitimate obligations associated with prior Applications for Payment.
3. The amount of retainage with respect to progress payments will be as stipulated in the Agreement.

B. Review of Applications:

1. Engineer will, within 10 days after receipt of each Application for Payment, either indicate in writing a recommendation of payment and present the Application to Owner or return the Application to Contractor indicating in writing Engineer's reasons for refusing to recommend payment. In the latter case, Contractor may make the necessary corrections and resubmit the Application.
2. Engineer's recommendation of any payment requested in an Application for Payment will constitute a representation by Engineer to Owner, based on Engineer's observations of the executed Work as an experienced and qualified design professional, and on Engineer's review of the Application for Payment and the accompanying data and schedules, that to the best of Engineer's knowledge, information and belief:
 - a. the Work has progressed to the point indicated;
 - b. the quality of the Work is generally in accordance with the Contract Documents (subject to an evaluation of the Work as a functioning whole prior to or upon Substantial Completion, the results of any subsequent tests called for in the Contract Documents, a final determination of quantities and classifications for Unit Price Work under Paragraph 9.07, and any other qualifications stated in the recommendation); and

- c. the conditions precedent to Contractor's being entitled to such payment appear to have been fulfilled in so far as it is Engineer's responsibility to observe the Work.

3. By recommending any such payment Engineer will not thereby be deemed to have represented that:

- a. inspections made to check the quality or the quantity of the Work as it has been performed have been exhaustive, extended to every aspect of the Work in progress, or involved detailed inspections of the Work beyond the responsibilities specifically assigned to Engineer in the Contract Documents; or
- b. there may not be other matters or issues between the parties that might entitle Contractor to be paid additionally by Owner or entitle Owner to withhold payment to Contractor.

4. Neither Engineer's review of Contractor's Work for the purposes of recommending payments nor Engineer's recommendation of any payment, including final payment, will impose responsibility on Engineer:

- a. to supervise, direct, or control the Work, or
- b. for the means, methods, techniques, sequences, or procedures of construction, or the safety precautions and programs incident thereto, or
- c. for Contractor's failure to comply with Laws and Regulations applicable to Contractor's performance of the Work, or
- d. to make any examination to ascertain how or for what purposes Contractor has used the moneys paid on account of the Contract Price, or
- e. to determine that title to any of the Work, materials, or equipment has passed to Owner free and clear of any Liens.

5. Engineer may refuse to recommend the whole or any part of any payment if, in Engineer's opinion, it would be incorrect to make the

representations to Owner stated in Paragraph 14.02.B.2. Engineer may also refuse to recommend any such payment or, because of subsequently discovered evidence or the results of subsequent inspections or tests, revise or revoke any such payment recommendation previously made, to such extent as may be necessary in Engineer's opinion to protect Owner from loss because:

- a. the Work is defective, or completed Work has been damaged, requiring correction or replacement;
- b. the Contract Price has been reduced by Change Orders;
- c. Owner has been required to correct defective Work or complete Work in accordance with Paragraph 13.09; or
- d. Engineer has actual knowledge of the occurrence of any of the events enumerated in Paragraph 15.02.A.

C. *Payment Becomes Due:*

1. Ten days after presentation of the Application for Payment to Owner with Engineer's recommendation, the amount recommended will (subject to the provisions of Paragraph 14.02.D) become due, and when due will be paid by Owner to Contractor.

D. *Reduction in Payment:*

1. Owner may refuse to make payment of the full amount recommended by Engineer because:
 - a. claims have been made against Owner on account of Contractor's performance or furnishing of the Work;
 - b. Liens have been filed in connection with the Work, except where Contractor has delivered a specific bond satisfactory to Owner to secure the satisfaction and discharge of such Liens;
 - c. there are other items entitling Owner to a set-off against the amount recommended; or
 - d. Owner has actual knowledge of the occurrence of any of the events

enumerated in Paragraphs 14.02.B.5.a through 14.02.B.5.c or Paragraph 15.02.A.

2. If Owner refuses to make payment of the full amount recommended by Engineer, Owner will give Contractor immediate written notice (with a copy to Engineer) stating the reasons for such action and promptly pay Contractor any amount remaining after deduction of the amount so withheld. Owner shall promptly pay Contractor the amount so withheld, or any adjustment thereto agreed to by Owner and Contractor, when Contractor remedies the reasons for such action.
3. Upon a subsequent determination that Owner's refusal of payment was not justified, the amount wrongfully withheld shall be treated as an amount due as determined by Paragraph 14.02.C.1 and subject to interest as provided in the Agreement.

14.03 *Contractor's Warranty of Title*

- A. Contractor warrants and guarantees that title to all Work, materials, and equipment covered by any Application for Payment, whether incorporated in the Project or not, will pass to Owner no later than the time of payment free and clear of all Liens.

14.04 *Substantial Completion*

- A. When Contractor considers the entire Work ready for its intended use Contractor shall notify Owner and Engineer in writing that the entire Work is substantially complete (except for items specifically listed by Contractor as incomplete) and request that Engineer issue a certificate of Substantial Completion.
- B. Promptly after Contractor's notification, Owner, Contractor, and Engineer shall make an inspection of the Work to determine the status of completion. If Engineer does not consider the Work substantially complete, Engineer will notify Contractor in writing giving the reasons therefor.
- C. If Engineer considers the Work substantially complete, Engineer will deliver to Owner a tentative certificate of Substantial Completion which shall fix the date of Substantial Completion. There shall be attached to the certificate a tentative list of items to be completed or corrected before final payment. Owner shall have seven days after receipt of the tentative certificate during which to

make written objection to Engineer as to any provisions of the certificate or attached list. If, after considering such objections, Engineer concludes that the Work is not substantially complete, Engineer will, within 14 days after submission of the tentative certificate to Owner, notify Contractor in writing, stating the reasons therefor. If, after consideration of Owner's objections, Engineer considers the Work substantially complete, Engineer will, within said 14 days, execute and deliver to Owner and Contractor a definitive certificate of Substantial Completion (with a revised tentative list of items to be completed or corrected) reflecting such changes from the tentative certificate as Engineer believes justified after consideration of any objections from Owner.

D. At the time of delivery of the tentative certificate of Substantial Completion, Engineer will deliver to Owner and Contractor a written recommendation as to division of responsibilities pending final payment between Owner and Contractor with respect to security, operation, safety, and protection of the Work, maintenance, heat, utilities, insurance, and warranties and guarantees. Unless Owner and Contractor agree otherwise in writing and so inform Engineer in writing prior to Engineer's issuing the definitive certificate of Substantial Completion, Engineer's aforesaid recommendation will be binding on Owner and Contractor until final payment.

E. Owner shall have the right to exclude Contractor from the Site after the date of Substantial Completion subject to allowing Contractor reasonable access to remove its property and complete or correct items on the tentative list.

14.05 *Partial Utilization*

A. Prior to Substantial Completion of all the Work, Owner may use or occupy any substantially completed part of the Work which has specifically been identified in the Contract Documents, or which Owner, Engineer, and Contractor agree constitutes a separately functioning and usable part of the Work that can be used by Owner for its intended purpose without significant interference with Contractor's performance of the remainder of the Work, subject to the following conditions:

1. Owner at any time may request Contractor in writing to permit Owner to use or occupy any such part of the Work which Owner believes to be ready for its intended use and

substantially complete. If and when Contractor agrees that such part of the Work is substantially complete, Contractor, Owner, and Engineer will follow the procedures of Paragraph 14.04.A through D for that part of the Work.

2. Contractor at any time may notify Owner and Engineer in writing that Contractor considers any such part of the Work ready for its intended use and substantially complete and request Engineer to issue a certificate of Substantial Completion for that part of the Work.

3. Within a reasonable time after either such request, Owner, Contractor, and Engineer shall make an inspection of that part of the Work to determine its status of completion. If Engineer does not consider that part of the Work to be substantially complete, Engineer will notify Owner and Contractor in writing giving the reasons therefor. If Engineer considers that part of the Work to be substantially complete, the provisions of Paragraph 14.04 will apply with respect to certification of Substantial Completion of that part of the Work and the division of responsibility in respect thereof and access thereto.

4. No use or occupancy or separate operation of part of the Work may occur prior to compliance with the requirements of Paragraph 5.10 regarding property insurance.

14.06 *Final Inspection*

A. Upon written notice from Contractor that the entire Work or an agreed portion thereof is complete, Engineer will promptly make a final inspection with Owner and Contractor and will notify Contractor in writing of all particulars in which this inspection reveals that the Work is incomplete or defective. Contractor shall immediately take such measures as are necessary to complete such Work or remedy such deficiencies.

14.07 *Final Payment*

A. *Application for Payment:*

1. After Contractor has, in the opinion of Engineer, satisfactorily completed all corrections identified during the final inspection and has delivered, in accordance with the Contract Documents, all maintenance and operating instructions, schedules, guarantees, bonds, certificates or other evidence of insurance, certificates of inspection, marked-up record documents (as provided in Paragraph 6.12), and other documents, Contractor may make application for final payment following the procedure for progress payments.
2. The final Application for Payment shall be accompanied (except as previously delivered) by:
 - a. all documentation called for in the Contract Documents, including but not limited to the evidence of insurance required by Paragraph 5.04.B.6;
 - b. consent of the surety, if any, to final payment;
 - c. a list of all Claims against Owner that Contractor believes are unsettled; and
 - d. complete and legally effective releases or waivers (satisfactory to Owner) of all Lien rights arising out of or Liens filed in connection with the Work.
3. In lieu of the releases or waivers of Liens specified in Paragraph 14.07.A.2 and as approved by Owner, Contractor may furnish receipts or releases in full and an affidavit of Contractor that: (i) the releases and receipts include all labor, services, material, and equipment for which a Lien could be filed; and (ii) all payrolls, material and equipment bills, and other indebtedness connected with the Work for which Owner might in any way be responsible, or which might in any way result in liens or other burdens on Owner's property, have been paid or otherwise satisfied. If any Subcontractor or Supplier fails to furnish such a release or receipt in full, Contractor may furnish a bond or other collateral satisfactory to Owner to indemnify Owner against any Lien.

B. *Engineer's Review of Application and Acceptance:*

1. If, on the basis of Engineer's observation of the Work during construction and final inspection, and Engineer's review of the final Application for Payment and accompanying documentation as required by the Contract Documents, Engineer is satisfied that the Work has been completed and Contractor's other obligations under the Contract Documents have been fulfilled, Engineer will, within ten days after receipt of the final Application for Payment, indicate in writing Engineer's recommendation of payment and present the Application for Payment to Owner for payment. At the same time Engineer will also give written notice to Owner and Contractor that the Work is acceptable subject to the provisions of Paragraph 14.09. Otherwise, Engineer will return the Application for Payment to Contractor, indicating in writing the reasons for refusing to recommend final payment, in which case Contractor shall make the necessary corrections and resubmit the Application for Payment.

C. *Payment Becomes Due:*

1. Thirty days after the presentation to Owner of the Application for Payment and accompanying documentation, the amount recommended by Engineer, less any sum Owner is entitled to set off against Engineer's recommendation, including but not limited to liquidated damages, will become due and will be paid by Owner to Contractor.

14.08 *Final Completion Delayed*

- A. If, through no fault of Contractor, final completion of the Work is significantly delayed, and if Engineer so confirms, Owner shall, upon receipt of Contractor's final Application for Payment (for Work fully completed and accepted) and recommendation of Engineer, and without terminating the Contract, make payment of the balance due for that portion of the Work fully completed and accepted. If the remaining balance to be held by Owner for Work not fully completed or corrected is less than the retainage stipulated in the Agreement, and if bonds have been furnished as required in Paragraph 5.01, the written consent of the surety to the payment of the balance due for that portion of the Work fully completed and

accepted shall be submitted by Contractor to Engineer with the Application for such payment. Such payment shall be made under the terms and conditions governing final payment, except that it shall not constitute a waiver of Claims.

14.09 *Waiver of Claims*

A. The making and acceptance of final payment will constitute:

1. a waiver of all Claims by Owner against Contractor, except Claims arising from unsettled Liens, from defective Work appearing after final inspection pursuant to Paragraph 14.06, from failure to comply with the Contract Documents or the terms of any special guarantees specified therein, or from Contractor's continuing obligations under the Contract Documents; and
2. a waiver of all Claims by Contractor against Owner other than those previously made in accordance with the requirements herein and expressly acknowledged by Owner in writing as still unsettled.

ARTICLE 15 – SUSPENSION OF WORK AND TERMINATION

15.01 *Owner May Suspend Work*

A. At any time and without cause, Owner may suspend the Work or any portion thereof for a period of not more than 90 consecutive days by notice in writing to Contractor and Engineer which will fix the date on which Work will be resumed. Contractor shall resume the Work on the date so fixed. Contractor shall be granted an adjustment in the Contract Price or an extension of the Contract Times, or both, directly attributable to any such suspension if Contractor makes a Claim therefor as provided in Paragraph 10.05.

15.02 *Owner May Terminate for Cause*

A. The occurrence of any one or more of the following events will justify termination for cause:

1. Contractor's persistent failure to perform the Work in accordance with the Contract Documents (including, but not limited to, failure to supply sufficient skilled workers or suitable materials or equipment or failure to adhere to the Progress Schedule established

under Paragraph 2.07 as adjusted from time to time pursuant to Paragraph 6.04);

2. Contractor's disregard of Laws or Regulations of any public body having jurisdiction;
3. Contractor's repeated disregard of the authority of Engineer; or
4. Contractor's violation in any substantial way of any provisions of the Contract Documents.

B. If one or more of the events identified in Paragraph 15.02.A occur, Owner may, after giving Contractor (and surety) seven days written notice of its intent to terminate the services of Contractor:

1. exclude Contractor from the Site, and take possession of the Work and of all Contractor's tools, appliances, construction equipment, and machinery at the Site, and use the same to the full extent they could be used by Contractor (without liability to Contractor for trespass or conversion);
2. incorporate in the Work all materials and equipment stored at the Site or for which Owner has paid Contractor but which are stored elsewhere; and
3. complete the Work as Owner may deem expedient.

C. If Owner proceeds as provided in Paragraph 15.02.B, Contractor shall not be entitled to receive any further payment until the Work is completed. If the unpaid balance of the Contract Price exceeds all claims, costs, losses, and damages (including but not limited to all fees and charges of engineers, architects, attorneys, and other professionals and all court or arbitration or other dispute resolution costs) sustained by Owner arising out of or relating to completing the Work, such excess will be paid to Contractor. If such claims, costs, losses, and damages exceed such unpaid balance, Contractor shall pay the difference to Owner. Such claims, costs, losses, and damages incurred by Owner will be reviewed by Engineer as to their reasonableness and, when so approved by Engineer, incorporated in a Change Order. When exercising any rights or remedies under this Paragraph, Owner shall not be required to obtain the lowest price for the Work performed.

D. Notwithstanding Paragraphs 15.02.B and 15.02.C, Contractor's services will not be terminated if Contractor begins within seven days of receipt of notice of intent to terminate to correct its failure to perform and proceeds diligently to cure such failure within no more than 30 days of receipt of said notice.

E. Where Contractor's services have been so terminated by Owner, the termination will not affect any rights or remedies of Owner against Contractor then existing or which may thereafter accrue. Any retention or payment of moneys due Contractor by Owner will not release Contractor from liability.

F. If and to the extent that Contractor has provided a performance bond under the provisions of Paragraph 5.01.A, the termination procedures of that bond shall supersede the provisions of Paragraphs 15.02.B and 15.02.C.

15.03 *Owner May Terminate For Convenience*

A. Upon seven days written notice to Contractor and Engineer, Owner may, without cause and without prejudice to any other right or remedy of Owner, terminate the Contract. In such case, Contractor shall be paid for (without duplication of any items):

1. completed and acceptable Work executed in accordance with the Contract Documents prior to the effective date of termination, including fair and reasonable sums for overhead and profit on such Work;
2. expenses sustained prior to the effective date of termination in performing services and furnishing labor, materials, or equipment as required by the Contract Documents in connection with uncompleted Work, plus fair and reasonable sums for overhead and profit on such expenses;
3. all claims, costs, losses, and damages (including but not limited to all fees and charges of engineers, architects, attorneys, and other professionals and all court or arbitration or other dispute resolution costs) incurred in settlement of terminated contracts with Subcontractors, Suppliers, and others; and
4. reasonable expenses directly attributable to termination.

B. Contractor shall not be paid on account of loss of anticipated profits or revenue or other economic loss arising out of or resulting from such termination.

15.04 *Contractor May Stop Work or Terminate*

A. If, through no act or fault of Contractor, (i) the Work is suspended for more than 90 consecutive days by Owner or under an order of court or other public authority, or (ii) Engineer fails to act on any Application for Payment within 30 days after it is submitted, or (iii) Owner fails for 30 days to pay Contractor any sum finally determined to be due, then Contractor may, upon seven days written notice to Owner and Engineer, and provided Owner or Engineer do not remedy such suspension or failure within that time, terminate the Contract and recover from Owner payment on the same terms as provided in Paragraph 15.03.

B. In lieu of terminating the Contract and without prejudice to any other right or remedy, if Engineer has failed to act on an Application for Payment within 30 days after it is submitted, or Owner has failed for 30 days to pay Contractor any sum finally determined to be due, Contractor may, seven days after written notice to Owner and Engineer, stop the Work until payment is made of all such amounts due Contractor, including interest thereon. The provisions of this Paragraph 15.04 are not intended to preclude Contractor from making a Claim under Paragraph 10.05 for an adjustment in Contract Price or Contract Times or otherwise for expenses or damage directly attributable to Contractor's stopping the Work as permitted by this Paragraph.

ARTICLE 16 – DISPUTE RESOLUTION

16.01 *Methods and Procedures*

A. Either Owner or Contractor may request mediation of any Claim submitted to Engineer for a decision under Paragraph 10.05 before such decision becomes final and binding. The mediation will be governed by the Construction Industry Mediation Rules of the American Arbitration Association in effect as of the Effective Date of the Agreement. The request for mediation shall be submitted in writing to the American Arbitration Association and the other party to the Contract. Timely submission of the request shall stay the effect of Paragraph 10.05.E.

B. Owner and Contractor shall participate in the mediation process in good faith. The process shall be concluded within 60 days of filing of the request. The date of termination of the mediation shall be determined by application of the mediation rules referenced above.

C. If the Claim is not resolved by mediation, Engineer's action under Paragraph 10.05.C or a denial pursuant to Paragraphs 10.05.C.3 or 10.05.D shall become final and binding 30 days after termination of the mediation unless, within that time period, Owner or Contractor:

1. elects in writing to invoke any dispute resolution process provided for in the Supplementary Conditions; or
2. agrees with the other party to submit the Claim to another dispute resolution process; or
3. gives written notice to the other party of the intent to submit the Claim to a court of competent jurisdiction.

ARTICLE 17 – MISCELLANEOUS

17.01 *Giving Notice*

- A. Whenever any provision of the Contract Documents requires the giving of written notice, it will be deemed to have been validly given if:
1. delivered in person to the individual or to a member of the firm or to an officer of the corporation for whom it is intended; or
 2. delivered at or sent by registered or certified mail, postage prepaid, to the last business address known to the giver of the notice.

17.02 *Computation of Times*

- A. When any period of time is referred to in the Contract Documents by days, it will be computed to exclude the first and include the last day of such period. If the last day of any such period falls on a Saturday or Sunday or on a day made a legal holiday by the law of the applicable jurisdiction, such day will be omitted from the computation.

17.03 *Cumulative Remedies*

- A. The duties and obligations imposed by these General Conditions and the rights and remedies

available hereunder to the parties hereto are in addition to, and are not to be construed in any way as a limitation of, any rights and remedies available to any or all of them which are otherwise imposed or available by Laws or Regulations, by special warranty or guarantee, or by other provisions of the Contract Documents. The provisions of this Paragraph will be as effective as if repeated specifically in the Contract Documents in connection with each particular duty, obligation, right, and remedy to which they apply.

17.04 *Survival of Obligations*

- A. All representations, indemnifications, warranties, and guarantees made in, required by, or given in accordance with the Contract Documents, as well as all continuing obligations indicated in the Contract Documents, will survive final payment, completion, and acceptance of the Work or termination or completion of the Contract or termination of the services of Contractor.

17.05 *Controlling Law*

- A. This Contract is to be governed by the law of the state in which the Project is located.

17.06 *Headings*

- A. Article and paragraph headings are inserted for convenience only and do not constitute parts of these General Conditions.

SUPPLEMENTARY CONDITIONS

SUPPLEMENTARY CONDITIONS

TABLE OF CONTENTS

PART I – AMENDMENTS TO GENERAL CONDITIONS

<u>Article Number</u>	<u>Title</u>
1	DEFINITIONS AND TERMINOLOGY
2	PRELIMINARY MATTERS
3	CONTRACT DOCUMENTS; INTENT, AMENDING, REUSE
4	AVAILABILITY OF LANDS; SUBSURFACE AND PHYSICAL CONDITIONS; HAZARDOUS ENVIRONMENTAL CONDITIONS; REFERENCE POINTS
5	BONDS AND INSURANCE
6	CONTRACTOR'S RESPONSIBILITIES
7	OTHER WORK AT THE SITE
8	OWNER'S RESPONSIBILITIES
9	ENGINEER'S STATUS DURING CONSTRUCTION
11	COST OF THE WORK; ALLOWANCES; UNIT PRICE WORK
12	CHANGE OF CONTRACT PRICE; CHANGE OF CONTRACT TIMES
13	TESTS AND INSPECTIONS; CORRECTION, REMOVAL OR ACCEPTANCE OF DEFECTIVE WORK
14	PAYMENTS TO CONTRACTOR AND COMPLETION
15	SUSPENSION OF WORK AND TERMINATION
16	DISPUTE RESOLUTION
17	MISCELLANEOUS

PART II – FEDERAL, STATE AND LOCAL GOVERNMENT PROVISIONS

1.0	FEDERAL GOVERNMENT PROVISIONS
2.0.	COMMONWEALTH OF MASSACHUSETTS PROVISIONS

SUPPLEMENTARY CONDITIONS

PART I - AMENDMENTS TO GENERAL CONDITIONS

These Supplementary Conditions amend or supplement the Standard General Conditions of the Construction Contract (EJCDC Document No. C-700, 2007 edition) and other provisions of the Contract Documents as indicated below. All provisions which are not so amended or supplemented remain in full force and effect.

ARTICLE 1 - DEFINITIONS AND TERMINOLOGY

SC-1.01A.42.

Delete paragraph 1.01A.42. of the General Conditions in its entirety and replace with the following:

42. Specifications - Sections included under Divisions 1 through 15 of the Project Manual.

SC-1.01A.45.

Insert the following at the beginning of the definition before the words "The time at....."

The Work required by the Contract has been completed except for work having a Contract Price of less than one per cent of the then adjusted total contract price, or

ARTICLE 2 - PRELIMINARY MATTERS

SC-2.01B.

Delete paragraph 2.01B. of the General Conditions in its entirety and replace with the following:

B. Before any Work at the site is started, Contractor shall deliver to Owner, with copies to Engineer and each additional insured identified in Article 5 of the Supplementary Conditions, certificates of insurance (and other evidence requested by Owner) which Contractor is required to purchase and maintain in accordance with the requirements of Article 5.

SC-2.03A.

Delete paragraph 2.03A of the General Conditions in its entirety and replace with the following:

A. The Contract Time will commence to run on the twentieth day following the Effective Date of the Agreement.

ARTICLE 3 - CONTRACT DOCUMENTS: INTENT, AMENDING, REUSE

SC-3.01C.

Add the following new paragraph immediately after Paragraph 3.01C. of the General Conditions which is to read as follows:

D. Each and every provision of law and clause required by law to be inserted in these Contract Documents shall be deemed to be inserted herein, and they shall be read and enforced as though it were included herein, and if through mistake or otherwise, any such provision is not inserted, or if not correctly inserted, then upon the application of either party, the Contract Documents shall forthwith be physically amended to make such insertion.

ARTICLE 4 - AVAILABILITY OF LANDS; SUBSURFACE AND PHYSICAL CONDITIONS;
HAZARDOUS ENVIRONMENTAL CONDITIONS; REFERENCE POINTS

SC-4.01A.

Add the following new paragraph immediately after paragraph 4.01A. of the General Conditions which is to read as follows:

1. If all lands and rights-of-way are not obtained as herein contemplated before construction begins, Contractor shall begin the Work upon such land and rights-of-way as Owner has previously acquired.

SC-4.02A.2.

Add the following new paragraph immediately after paragraph 4.02A.2 of the General Conditions which is to read as follows:

a. In the preparation of Drawings and Specifications, the Engineer has relied upon internal television inspection logs and videos of the existing sewer system at the site. These videos may be examined by appointment at the Engineer's office during regular business hours.

SC-4.03C.3.

Add the following new paragraph immediately after paragraph 4.03C.3. of the General Conditions which is to read as follows:

D. Adjustments resulting from subsurface or latent physical conditions will be in accordance with Massachusetts General Law Chapter 30, Section 39N included in PART II of the Supplementary Conditions.

SC-4.05A.

Add the following new paragraph immediately after paragraph 4.05A of the General Conditions which is to read as follows:

B. Engineer may check the lines, elevations, reference marks, batter boards, etc., set by Contractor, and Contractor shall correct any errors disclosed by such check. Such a check shall not be considered as approval of Contractor's work and shall not relieve Contractor of the responsibility for accurate construction of the entire Work. Contractor shall furnish personnel to assist Engineer in checking lines and grades.

ARTICLE 5 - BONDS AND INSURANCE

SC-5.01A.

Delete the third sentence in paragraph 5.01A of the General Conditions and replace with the following. Contractor shall also furnish Efficiency Guarantee Bonds in accordance with Article entitled MANUFACTURER'S EXPERIENCE in the Instructions to Bidders and executed on forms approved by the Owner.

SC-5.03B

Add 2 new paragraphs immediately after paragraph 5.03E of the General Conditions which are to read as follows:

F. Contractor shall provide evidence of its insurance coverage on the ACORD certificate of insurance form and shall include the following statement in its entirety in the section of the form entitled "Description of Operations/Locations/Vehicles/Special Items".

The Town of Manchester by the Sea and VHB Inc., and their officers, directors, partners, employees and other consultants and subcontractors are named as additional insureds with respect to the insured's Commercial General Liability and Automobile Liability Insurance Policies. All insurers waive all rights of subrogation against the Town of Manchester by the Sea and VHB Inc., their officers, directors, partners, employees and other consultants and subcontractors. All insurance is primary for all claims covered thereby. Commercial General Liability Insurance includes contractual liability coverage.

SC-5.04A.

The limits of liability for the insurance required by paragraph 5.04A. of the General Conditions shall provide coverage for not less than the following amounts or greater where required by law:

5.04.A.1 and 5.04.A.2 Workers' Compensation and Employer's Liability Insurance

- | | | |
|---------------------------|-----------|---|
| (1) Worker's Compensation | | in accordance with M.G.L. c.149, Sect. 34A. |
| (2) Employer's Liability | \$500,000 | Each Occurrence |
| | \$500,000 | Disease per employee |

5.04A.3., 5.04A.4., and 5.04A.5. Commercial General Liability including Premise/Operations; Explosion, Collapse and Underground Property Damage; Products/Completed Operations, Broad Form Contractual, Independent Contractors; Broad Form Property Damage; and Personal Injury liabilities:

- | | | |
|----------------------|-------------|------------------|
| (1) Bodily Injury: | \$1,000,000 | Each Occurrence |
| | \$1,000,000 | Annual Aggregate |
| (2) Property Damage: | \$1,000,000 | Each Occurrence |
| | \$1,000,000 | Annual Aggregate |
| (3) Personal Injury: | \$1,000,000 | Annual Aggregate |

5.04A.6. Comprehensive Automobile Liability including all owned (private and others), hired and non-owned vehicles:

(1) Bodily Injury	\$1,000,000	Each Person
	\$1,000,000	Each Accident
(2) Property Damage	\$1,000,000	Each Occurrence

SC 5.04B.1.

Delete paragraph 5.04B.1. of the General Conditions in its entirety and replace with the following:

1. The insurance required by paragraph 5.04A.3 through 5.04A.6 inclusive will provide primary coverage for all claims covered thereby. With respect to insurance required by Paragraph 5.04.A.6 include as additional insured Owner and Engineer, and any other individuals or entities identified in the Supplementary Conditions, all of whom shall be listed as additional insureds and include coverage for the respective officers, directors, partners, employees, agents, consultants and subcontractors of each and any of all such additional insureds

SC-5.04B.6.

Add two new paragraphs immediately after paragraph 5.04.B.6.b. of the General Conditions which is to read as follows:

7. Contractor may purchase and maintain excess liability insurance in the umbrella form in order to satisfy the minimum amounts required for the insurance to be purchased and maintained in accordance with paragraph 5.04. Evidence of such excess liability insurance shall be delivered to Owner in accordance with paragraph 2.01B. in the form of a certificate indicating the policy numbers and minimum coverage amounts of all underlying insurance. The umbrella liability insurance shall have a combined single limit of not less than \$5,000,000.

8. All policies required by this paragraph 5.04 shall contain provisions to the effect that the insurer(s) waive all right of subrogation against the Owner, Engineer and their officers, directors, partners, employees and other consultants and subcontractors of each and any of them.

SC-5.05A.

Delete paragraph 5.05A. of the General Conditions in its entirety and replace with the following:

A. Contractor shall purchase and maintain a separate Owner's Protective Liability policy, issued to Owner at the expense of Contractor, including Owner and Engineer as named insured. This insurance shall provide coverage for not less than the following amounts:

5.05A.1. Bodily Injury	\$1,000,000	Each Occurrence
5.05A.2. Property Damage	\$1,000,000	Each Occurrence
	\$1,000,000	Annual Aggregate

SC-5.05A

Add the following new paragraph immediately after paragraph 5.05.A.2 of the General Conditions which is to read as follows:

B. All policies required by this paragraph 5.05 shall contain provisions to the effect that the insurer(s) waive all rights of subrogation against the Owner, Engineer and their officers, directors, partners, employees and other consultants and subcontractors of each and any of them.

SC-5.06A.

Delete paragraphs 5.06A. and A1 thru A7 of the General Conditions in their entirety.

SC-5.06B.

Delete paragraph 5.06B. of the General Conditions in its entirety.

SC-5.06C.

Delete Paragraph 5.06C. of the General Conditions in its entirety.

SC-5.06D.

Delete paragraph 5.06D. of the General Conditions in its entirety.

SC-5.06E.

Delete paragraph 5.06E. of the General Conditions in its entirety.

SC-5.07A.

Delete paragraph 5.07A. of the General Conditions in its entirety and replace with the following.

A. All insurance policies provided by the Contractor shall contain provisions to the effect that the insurer waives all rights of subrogation against any of the insured, loss payee, (and the officers, directors, members, partners, employees, agents, consultants and subcontractors of each and any of them) Owner and the Engineer.

SC-5.08A.

Delete paragraph 5.08A. of the General Conditions in its entirety.

SC-5.08B.

Delete paragraph 5.08B. of the General Conditions in its entirety.

SC-5.09A.

Delete paragraph 5.09A. of the General Conditions in its entirety and replace with the following:

A. If Owner has any objection to the coverage afforded by or other provisions of the insurance required to be purchased and maintained by Contractor in accordance with this Article 5 on the basis of its not complying with the Contract Documents, Owner will notify Contractor in writing thereof within ten days of the date of delivery of such certificates to Owner in accordance with paragraph 2.01. Contractor will

provide such additional information in respect of insurance provided by Contractor as Owner may reasonably request.

ARTICLE 6 - CONTRACTOR'S RESPONSIBILITIES

SC-6.02

Add the following 2 new paragraphs immediately after paragraph 6.02B. of the General Conditions which are to read as follows:

C. Regular working hours are defined as 8 hours per day, Monday through Friday, excluding holidays, between the hours of 7:00 AM and 7:00 PM. Requests to work other than regular working hours shall be submitted to Engineer not less than 48 hours prior to any proposed weekend work or scheduled extended work weeks. Occasional unscheduled overtime on weekdays may be permitted provided two hours notice is given to Engineer.

D. Contractor shall reimburse the Owner for additional engineering and/or inspection costs incurred as a result of overtime work in excess of the regular working hours stipulated in Article SC-6.02C. At Owner's option, overtime costs may either be deducted from the Contractor's monthly payment request or deducted from the Contractor's retention prior to release of final payment. Overtime costs for the Owner's personnel shall be based on the individual's current overtime wage rate. Overtime costs for personnel employed by the Engineer or Owner's independent testing laboratory shall be calculated in accordance with the terms of their respective contracts with the Owner.

SC-6.02B.

Add the following new paragraphs immediately after paragraph 6.02B. of the General Conditions which are to read as follows:

C. This Agreement is subject to the applicable provisions of the Contract Work Hours and Safety Standards Act, Public Law 87-581, 87th Congress. No Contractor or Subcontractor contracting for any part of the Work shall require or permit any laborer or mechanic to be employed on the Work in excess of forty hours in any work week unless such laborer or mechanic receives compensation at a rate not less than one and one-half times that person's basic rate of pay for all hours worked in excess of forty hours in such work week.

D. Contractor shall employ only competent persons to do the work and whenever Owner shall notify Contractor, in writing, that any person on the Work appears to be incompetent, disorderly, or otherwise unsatisfactory, such person shall be removed from the Project and shall not again be employed on it except with the consent of Owner.

E. Contractor and Subcontractors shall, insofar as practicable, give preference in the hiring of workers for the Project to qualified local residents with first preference being given to citizens of the United States who have served in the armed forces of the United States and have been honorably discharged therefrom or released from active duty therein.

F. Contractor and all Subcontractors shall pay to all laborers and mechanics employed for the construction covered by this Contract the minimum rates of pay as determined by the Secretary of Labor in accordance with the Act of March 3, 1931, as amended, known as the Davis Bacon Act (40 U.S.C. 276a through 276a 7). Furthermore, Contractor and Subcontractors shall adhere to the stipulations and

provisions published by the Secretary of Health, Education, and Welfare in "Labor Standards (Federal Water Pollution Control Act)." The Wage Rate Schedule as prepared by the Secretary of Labor and the "Labor Standards" are part of this Contract and are included in PART II of these Supplementary Conditions.

G. Except as may be otherwise required by law, all claims and disputes pertaining to the classification of labor employed on the project under this Contract shall be decided by the governing body having jurisdiction.

H. Contractor and all Subcontractors shall comply with the Regulations of the Secretary of Labor made pursuant to the Anti-Kickback Act of June 30, 1940 (40 U.S.C. 276c) and all amendments or modifications thereto. Contractor and all Subcontractors shall furnish Owner with weekly Statements of Compliance. In case of Subcontracts, Contractor shall cause appropriate provision to be inserted in all subcontracts for the Work which Contractor may let to ensure compliance with said Anti-Kickback Act by all Subcontractors subject thereto, and Contractor shall be responsible for the submission of all Statements of Compliance required of Subcontractors by said Anti-Kickback Act except as the Secretary of Labor may specifically provide for reasonable limitations, variations, and exemptions from the requirements thereof. These Regulations are part of this Contract and are included in PART II of these Supplementary Conditions.

I. Contractor and all subcontractors shall comply with the Massachusetts Prevailing Wage law as contained in M.G.L. chapter 149 sections 26-27 which are included in Part II of these Supplementary Conditions.

SC-6.06A.

Delete Paragraphs 6.06A. and 6.06B. of the General Conditions in their entirety and replace with the following:

A. Contractor shall not employ any Subcontractor, Supplier or other person or organization, (including those who are to furnish the principal items of materials or equipment), whether initially or as a substitute, against whom Owner may have reasonable objection. Acceptance of any Subcontractor, other person or organization by Owner shall not constitute a waiver of any right of Owner to reject defective Work. Contractor shall not be required to employ any Subcontractor, other person or organization against whom Contractor has reasonable objection.

B. Not Used.

SC-6.06C.

Add the following new sentence at the end of paragraph 6.06C. of the General Conditions to read as follows:

Contractor shall make payments to Subcontractors in accordance with Massachusetts General Law Chapter 30, Section 39F which is included in PART II of these Supplementary Conditions.

SC-6.06E.

Add the following new sentence at the end of paragraph 6.06E of the General Conditions to read as follows:

Owner or Engineer may furnish to any such Subcontractor, Supplier or other person or organization, to the extent practicable, information about amounts paid on their behalf to Contractor in accordance with Contractor's Applications for Payment.

SC-6.07B

Delete paragraph 6.07B of the General Conditions in its entirety.

SC-6.08A

Delete the first and second sentences of Paragraph 6.08A of the General Conditions in their entirety and replace with the following:

Contractor shall comply with the guidelines established in the Division of Municipal Services (DMS) Construction Grants Policy Memorandum No. CG-2 (Permits) included in Part II of the Supplementary Conditions.

SC-6.10A

Add the following new sentences at the end of paragraph 6.10A of the General Conditions to read as follows:

The materials and supplies to be used in the Work of this Contract are exempt from the Sales and Use Tax of the Commonwealth of Massachusetts. Contractor shall obtain the proper certificates, maintain the necessary records and otherwise comply with the requirements of Chapter 14 of the Acts of 1966 and any amendments thereto.

SC-6.16A.

Delete the last sentence in paragraph 6.16A. of the General Conditions in its entirety and replace with the following:

If Engineer determines that the incident giving rise to the emergency action was not the responsibility of the Contractor and that a change in the Contract Document is required because of the action taken by the Contractor in response to such an emergency, a Work Change Directive or Change Order will be issued.

SC-6.17D.1.

Add the following new sentence at the end of paragraph 6.17.D.1 of the General Conditions to read as follows:

Approval of Shop Drawings for equipment requiring Efficiency Guarantee Bonds will be withheld until the receipt of such Bonds.

SC-6.19A.

Add the following new paragraph immediately after paragraph 6.19A. of the General Conditions which is to read as follow:

B. The Contractor guarantees that the Work and Services to be performed under the Contract, and all workmanship, materials and equipment performed, furnished, used or installed in the construction of the same shall be free from defects and flaws, and shall be performed and furnished in strict accordance with the Drawings, Specifications, and other Contract Documents, that the strength of all parts of all manufactured equipment shall be adequate and as specified and that the performance test requirements of the Contract shall be fulfilled. This guarantee shall be for a period of one year from and after the date of completion and acceptance of the Work as stated in the final estimate. If part of the Work is accepted in accordance with that subsection of this AGREEMENT titled "Partial Acceptance," the guarantee for that part of the Work shall be for a period of one year from the date fixed for such acceptance.

1. If at any time within the said period of guarantee any part of the Work requires repairing, correction or replacement, the Owner may notify the Contractor in writing to make the required repairs, correction or replacements. If the Contractor neglects to commence making such repairs, corrections or replacements to the satisfaction of the Owner within seven (7) days from the date of receipt of such notice, or having commenced fails to prosecute such Work with diligence, the Owner may employ other persons to make said repairs, correction or replacements, and charge the costs, including compensation for additional professional services, to the Contractor.

2. The Contractor's guarantee under this clause, 6.19B, is in addition to the Contractor's express or implied warranties under this Agreement and State law and in no way diminish any other rights that the Owner may have against the Contractor.

SC-16.19C. and D.

Renumber 6.19B. and 6.19C. of the General Conditions to read 6.19C. and 6.19D.

SC-6.19D.

Add the following new paragraph immediately after paragraph 6.19D. of the General Conditions which is to read as follows:

E. Manufacturer's Guaranty/Warranty

1. The Contractor shall obtain the following guaranty/warranty from the manufacturer of all major pieces of equipment furnished and installed on this Project. Such guaranty/warranty shall be for the benefit of Owner and be furnished in writing by the manufacturer. The Contractor's and manufacturer's obligations under this provision are in addition to other express or implied warranties under the Contract Documents and under the law and in no way diminish any other right that the Owner may have against the Contractor or manufacturer for faulty material, equipment or work. The warranty period shall not be interpreted as a limitation on the time in which the Owner can enforce such other duties, obligations, rights, or remedies.

2. The manufacturer warrants and guarantees for a period of one year from the date of Substantial Completion, or such longer period that may be specified in the Contract Documents, that all materials and equipment furnished and installed shall be free from flaws, defects in material and workmanship and shall be in conformance with the Contract Documents.

SC-6.20A.

Delete paragraph 6.20A of the General Conditions in its entirety and replace with the following:

A. To the fullest extent permitted by Laws and Regulations, Contractor shall defend, indemnify and hold harmless Owner, Engineer and the officers, directors, members, partners, employees, agents, consultants and subcontractors of each and any of them from and against all claims, costs, losses and damages (including but not limited to all fees and charges of engineers, architects, attorneys and other professionals and all court or arbitration or other dispute resolution costs) arising out of or relating to the performance of the Work, provided that any such claim, cost or loss or damage:

1. is attributable to bodily injury, sickness, disease or death or to injury to or destruction of tangible property (other than the Work itself), including the loss of use resulting therefrom; and

2. is caused in whole or in part by any negligent act or omission of Contractor, any Subcontractor, any Supplier, or any individual or entity directly or indirectly employed by any of them to perform any of the Work or anyone for whose acts any of them may be liable, regardless of whether or not caused in part by any negligence or omission of an individual or entity indemnified hereunder or whether liability is imposed upon such indemnified party by Laws and Regulations regardless of the negligence of any such indemnified party unless caused by the sole negligence of a party indemnified hereunder. If through the acts of neglect on the part of Contractor, any other contractor or any Subcontractor shall suffer loss or damage on the Work, Contractor shall settle with such other contractor or Subcontractor by agreement or arbitration if such other contractor or Subcontractor will so settle. If such other contractor or Subcontractor shall assert any claim against Owner and/or Engineer, or the officers, directors, members, partners, employees, agents, consultants and subcontractors of each on account of any damage alleged to have been sustained, Owner shall notify Contractor, who shall defend, indemnify and save harmless Owner, Engineer, and the officers, directors, members, partners, employees, agents, consultants and subcontractors of each against any such claims.

SC-6.20C.

Delete paragraphs 6.20C, C.1 and C.2 of the General Conditions in their entirety.

SC-6.21E

Delete paragraph 6.21E of the General Conditions in its entirety and replace with the following:

E. Contractor shall not be responsible for the adequacy of the performance criteria or design criteria contained in the Contract Documents.

SC-6.21E.

Add the following new paragraph immediately after paragraph 6.21E. of the General Conditions which is to read as follows:

SC-6.22 Definitions; Contract Provisions; Management and Financial Statements; Enforcement

A. Contractor shall comply with all applicable provisions of Chapter 30, Section 39R of the Massachusetts General Laws regarding Contractor's records which is included in Part II of the Supplementary Conditions.

ARTICLE 7. OTHER WORK

SC-7.03C.

Add the following new paragraph immediately after paragraph 7.03C. of the General Conditions which is to read as follows:

7.04 Damage to Other Contractor's Property

A. Should Contractor cause damage to the work or property of any separate contractor at the site, or should any claim arising out of Contractor's performance of the Work at the site be made by any separate contractor against Contractor, Owner, Engineer, Engineer's Consultants, the Construction Coordinator or any other person, Contractor shall promptly attempt to settle with such other contractor by agreement, or to otherwise resolve the dispute by arbitration or at law. Contractor shall, to the fullest extent permitted by Laws and Regulations, defend, indemnify and hold Owner, Engineer, Engineer's Consultants and the Construction Coordinator harmless from and against all claims, damages, losses and expenses (including, but not limited to, fees of engineers, architects, attorneys and other professionals, and court and arbitration or mediation costs) arising directly, indirectly or consequentially out of any action, legal or equitable, brought by any separate contractor against Owner, Engineer, Engineer's Consultants or the Construction Coordinator to the extent based on a claim arising out of Contractor's performance of the Work. Should a separate contractor cause damage to the Work or property of Contractor or should the performance of work by any separate contractor at the site give rise to any other claim, Contractor shall not institute any action, legal or equitable, against Owner, Engineer, Engineer's Consultants or the Construction Coordinator or permit any action against any of them to be maintained and continued in its name or for its benefit in any court or before any arbiter which seeks to impose liability on or to recover damages from Owner, Engineer, Engineer's Consultants or the Construction Coordinator on account of any such damage or claim. If Contractor is delayed at any time in performing or furnishing Work by any act or neglect of a separate contractor and Owner and Contractor are unable to agree as to the extent of any adjustment in Contract Times attributable thereto, Contractor may make a claim for an extension of times in accordance with Article 12. An extension of the Contract Times shall be Contractor's exclusive remedy with respect to Owner, Engineer, Engineer's Consultants and Construction Coordinator for any delay, disruption, interference or hindrance caused by any separate contractor. This paragraph does not prevent recovery from Owner, Engineer, Engineer's Consultant or Construction Coordinator for activities that are their respective responsibilities.

ARTICLE 8. OWNER'S RESPONSIBILITIES

SC-8.06

Delete paragraph 8.06 of the General Conditions in its entirety.

ARTICLE 9 - ENGINEER'S STATUS DURING CONSTRUCTION

SC-9.03A.

Add the following new paragraph immediately after paragraph 9.03A of the General Conditions which is to read as follows:

B. Engineer will furnish a Resident Project Representative and assistants to assist Engineer in observing the performance of the Work. The duties and responsibilities of the Resident Project Representative will

be as enumerated in a document entitled "Duties, Responsibilities and Limitations of the Authority of Resident Project Representative" and will be made available to Contractor at the start of the Work.

ARTICLE 11 - COST OF THE WORK; ALLOWANCES; UNIT PRICE WORK

SC-11.01A.1.

Delete the second sentence in paragraph 11.01A.1. of the General Conditions in its entirety and replace with the following:

Such employees shall include foremen at the site.

SC-11.01A.1.

Add the following new paragraph immediately after paragraph 11.01A.1. of the General Conditions which is to read as follows:

a. Contractor shall establish, in the Agreement, the Direct Labor Cost percentage. This percentage, where approved by Owner, will be used in the determination of the Direct Labor Cost listed in the Change Order Form included in Part II of the Supplementary Conditions. The Direct Labor Costs are defined to include social security contributions, unemployment, excise and payroll taxes, workers' and workmen's compensation, health and retirement benefits, sick leave, vacation and holiday pay, and cost of premiums for all additional insurance required because of changes in the Work.

SC-11.02A.

Delete paragraphs 11.02A. thru D. of the General Conditions in their entirety.

SC-11.03D.

Delete paragraph 11.03D. of the General Conditions in its entirety and replace with the following:

D. The unit price of an item of Unit Price Work shall be subject to re-evaluation and adjustment under the following conditions:

1. if the total cost of a particular item of Unit Price Work amounts to 5 percent or more of the Contract Price and the variation in the quantity of that particular item of Unit Price Work performed by Contractor differs by more than 15 percent from the estimated quantity of such item indicated in the Agreement; and
2. if there is no corresponding adjustment with respect to any other item of Work; and
3. if Contractor believes that Contractor has incurred additional expense as a result thereof; or if Owner believes that the quantity variation entitles Owner to an adjustment in the unit price, either Owner or Contractor may make a claim for an adjustment in the Unit Price for that quantity by which the actual quantity exceeds 115% of the estimated quantity in accordance with Article 10.05 if the parties are unable to agree as to the effect of any such variations in the quantity of Unit Price Work performed.

ARTICLE 12 - CHANGE OF CONTRACT PRICE; CHANGE OF CONTRACT TIME

SC-12.01C.2.b.

In the second line of paragraph 12.01C.2.b, before the semicolon add the following words "based on subcontractor's Cost of the Work";

Delete "five percent" in paragraph 12.01C.2.b of the General Conditions and replace with "seven and one-half percent."

Delete "15 percent" in the seventh line of paragraph 12.01C.2.c, of the General Conditions and replace with "twenty percent" and delete "five percent" in the tenth line and replace with "seven and one-half percent."

ARTICLE 13 - TESTS AND INSPECTIONS; CORRECTION, REMOVAL OR ACCEPTANCE OF DEFECTIVE WORK

SC-13.05A.

Add the following new paragraph immediately after paragraph 13.05A. of the General Conditions to read as follows:

B. If Owner stops Work under Paragraph 13.05A. Contractor shall not be entitled to any extension of Contract Time or increase in Contract Price.

ARTICLE 14 - PAYMENTS TO CONTRACTOR AND COMPLETION

SC-14.02A.3.

Add the following new paragraph immediately after paragraph 14.02A.3 of the General Conditions which is to read as follows:

4. Contractor shall furnish evidence that payment received on the basis of materials and equipment not incorporated and suitably stored, has in fact been paid to the respective supplier(s) within sixty days of payment by Owner. Failure to provide such evidence of payment may result in the withdrawal of previous approval(s) and removal of the cost of related materials and equipment from the next submitted Application for Payment.

SC-14.02B.1

Delete paragraph 14.02B.1. of the General Condition in its entirety and replace with the following:

1. Progress Payments will be made in accordance with Massachusetts General Law Chapter 30, Section 39G, which is included in PART II of these Supplementary Conditions.

SC-14.03A.

Add the following new paragraphs immediately after paragraph 14.03A of the General Conditions which are to read as follows:

B. No materials or supplies for the Work shall be purchased by Contractor or Subcontractor subject to any chattel mortgage or under a conditional sale contract or other agreement by which an interest is retained by the seller. Contractor warrants that Contractor has good title to all materials and supplies used by Contractor in the Work, free from all liens, claims or encumbrances.

C. Contractor shall defend, indemnify and save Owner and Engineer harmless from all claims growing out of the lawful demands of Subcontractors, laborers, workmen, mechanics, materialmen, and furnishers of machinery and parts thereof, equipment, power tools, and all supplies, including commissary, incurred in the furtherance of the performance of this Contract. Contractor shall at Owner's request, furnish satisfactory evidence that all obligations of the nature hereinabove designated have been paid, discharged, or waived. If Contractor fails to do so, then Owner may, after having served written notice on the said Contractor either pay unpaid bills, of which Owner has written notice, direct, or withhold from the Contractor's unpaid compensation a sum of money deemed reasonably sufficient to pay any and all such lawful claims until satisfactory evidence is furnished that all liabilities have been fully discharged whereupon payment to Contractor shall be resumed, in accordance with the terms of this Contract, but in no event shall the provisions of this sentence be construed to impose any obligations upon Owner to either Contractor or Contractor's Surety. In paying any unpaid bills of the Contractor, Owner shall be deemed the agent of Contractor and any payment so made by Owner shall be considered as payment made under the Contract by Owner to Contractor and Owner shall not be liable to Contractor for any such payment made in good faith.

SC-14.07B.1.

Delete paragraph 14.07B.1. of the General Conditions in its entirety and replace with the following:

1. If, on the basis of Engineer's observation of the Work during construction and final inspection, and Engineer's review of the final Application for Payment and accompanying documentation - all as required by the Contract Documents, Engineer is satisfied that the Work has been completed and Contractor's other obligations under the Contract Documents have been fulfilled, Engineer will indicate in writing Engineer's recommendation of payment and present the Application to Owner for payment. Thereupon Engineer will give written notice to Owner and Contractor that the Work is acceptable subject to the provisions of paragraph 14.09. Otherwise, Engineer will return the Application to Contractor, indicating in writing the reasons for refusing to recommend final payment, in which case Contractor shall make the necessary corrections and resubmit the Application. If the Application and accompanying documentation are appropriate as to form and substance, Owner shall in accordance with the applicable Massachusetts General Law, pay Contractor the amount recommended by Engineer.

ARTICLE 15 - SUSPENSION OF WORK AND TERMINATION

SC-15.01A.

Delete paragraph 15.01A. of the General Conditions in its entirety and replace with the following:

A. Owner may order, at any time and without cause, suspension of the Work in accordance with Massachusetts General Law Chapter 30, Section 39O, which is included in Part II of the Supplementary Conditions.

SC-15.02A.4.

Add the following new paragraph immediately after paragraph 15.02.A.4 of the General Conditions which is to read as follows:

5. If Contractor abandons the Work, or sublets this Contract or any part thereof, without the previous written consent of Owner, or if the Contract or any claim thereunder shall be assigned by Contractor otherwise than as herein specified;

ARTICLE 16 - DISPUTE RESOLUTION

SC-16.01A

Delete the paragraph 16.01A of the General Conditions in its entirety and replace with the following:

Either Owner or Contractor may request mediation of any Claim submitted to Engineer for a decision under Paragraph 10.05 when such decision becomes final and binding. The mediation will be governed by the Construction Industry Mediation Rules of the American Arbitration Association in effect as of the Effective Date of this Agreement. The request for mediation shall be submitted in writing to the American Arbitration Association and the other party to the Contract.

SC-16.01C.3.

Add a new paragraph immediately after paragraph 16.01C.3. of the General Conditions which is to read as follows:

D. Contractor shall carry on the Work and maintain the progress schedule during the dispute resolution proceedings, unless otherwise agreed by Contractor and Owner in writing.

ARTICLE 17 - MISCELLANEOUS

SC-17.06

Add the following new paragraphs immediately after paragraph 17.06 of the General Conditions which are to read as follows:

17.07 Addresses

A. Both the address given in the Bid Form upon which this Agreement is founded, and Contractor's office at or near the site of the Work are hereby designated as places to either of which notices, letters, and other communications to Contractor shall be certified, mailed, or delivered. The delivering at the above named place, or depositing in a postpaid wrapper directed to the first-named place, in any post office box regularly maintained by the post office department, of any notice, letter or other communication to Contractor shall be deemed sufficient service thereof upon Contractor; and the date of said service shall be the date of such delivery or mailing. The first-named address may be changed at any time by an instrument in writing, executed and acknowledged by Contractor, and delivered to Owner and Engineer. Nothing herein contained shall be deemed to preclude or render inoperative the service of any notice, letter, or other communication upon Contractor personally.

17.08 Wage Rates

A. The requirements and provisions of all applicable laws and any amendments thereof or additions thereto as to the employment of labor, and to the schedule of minimum wage rates established in compliance with laws shall be a part of these Contract Documents. Copies of the wage schedules are included in PART II of these Supplementary Conditions. If, after the Notice of Award, it becomes necessary to employ any person in a trade or occupation not classified in the wage determinations, such person shall be paid at not less than such rates as shall be determined by the officials administering the laws mentioned above. Such approved minimum rate shall be retroactive to the time of the initial employment of such person in such trade or occupation. Contractor shall notify Owner of Contractor's intention to employ persons in trades or occupations not classified in sufficient time for Owner to obtain approved rates for such trades or occupations.

B. The schedules of wages referred to above are minimum rates only, and Owner will not consider any claims for additional compensation made by Contractor because of payment by Contractor of any wage rate in excess of the applicable rate contained in these Contract Documents. All disputes between Contractor and employees of Contractor in regard to the payment of wages in excess of these specified in the schedules shall be resolved by Contractor.

C. The said schedules of wages shall continue to be the minimum rates to be paid during the life of this Agreement and a legible copy of said schedules shall be kept posted in a conspicuous place at the site of the work.

D. Both Federal and State schedules of minimum wage rates are included in PART II of these Supplementary Conditions. Where rates differ, the higher rates shall apply as a minimum for that trade.

PART II FEDERAL, STATE AND LOCAL GOVERNMENT PROVISIONS

Federal, State and Local Government Provisions included herein, have been selected from those to which specific references have been made elsewhere in the Contract Documents. Each and every other provision of law or clause required by law to be inserted in this Contract shall be deemed to be also inserted herein in accordance with paragraph 3.01D of the Supplementary Conditions.

1.0. FEDERAL GOVERNMENT PROVISIONS

1.1. Federal Wage Rates

1.2. Disadvantaged Business Enterprise Program – DBE Subcontractor Participation Form (1 Page)

2.0. COMMONWEALTH OF MASSACHUSETTS PROVISIONS

2.1. Owner and Contractor agree that the following Commonwealth of Massachusetts Provisions apply to the work to be performed under this Contract and that these provisions supersede any conflicting provisions of this Contract.

2.2. Applicable provisions of Massachusetts General Laws and Regulations and/or the United States Code and Code of Federal Regulations govern this Contract and any provision in violation of the foregoing shall be deemed null, void and of no effect. Where conflict between Code of Federal Regulations and State Laws and Regulations exist, the more stringent requirement shall apply.

- 2.3. Special Provisions for Disadvantaged Business Enterprises - Massachusetts Department of Environmental Protection, Division of Municipal Services.
- 2.4. Massachusetts General Laws
 - 2.4.1. Chapter 30, Section 39F (5 Pages)
 - 2.4.2. Chapter 30, Section 39G (3 Pages)
 - 2.4.3. Chapter 30, Section 39I (1 Page)
 - 2.4.4. Chapter 30, Section 39J (1 Page)
 - 2.4.5. Chapter 30, Section 39L (1 Page)
 - 2.4.6. Chapter 30, Section 39M (3 Pages)
 - 2.4.7. Chapter 30, Section 39N (1 Page)
 - 2.4.8. Chapter 30, Section 39O (2 Pages)
 - 2.4.9. Chapter 30, Section 39P (1 Page)
 - 2.4.10. Chapter 30, Section 39Q (2 Pages)
 - 2.4.11. Chapter 30, Section 39R (4 Pages)
 - 2.4.12. Chapter 30, Section 39S (2 Pages)
 - 2.4.13. Chapter 82, Sections 40 and 40A through 40E (7 Pages)
 - 2.4.14. Chapter 82A, Section 1 (2 Pages)
 - 2.4.15. Chapter 149, Sections 26 and 27A through 27H (17 Pages)
 - 2.4.16. Chapter 149, Section 34 (2 Pages)
 - 2.4.17. Chapter 149, Section 44J (2 Pages)
- 2.5. State Wage Rates
- 2.6. Diesel Retrofit Requirements
- 2.7. Massachusetts Construction Grants Policy Memoranda (Currently 16 Memoranda).
- 2.8. Department of Environmental Protection Policy for Review of Sewer Line/Water Supply Protection.

SPECIAL PROVISIONS

**SPECIAL PROVISIONS
DOWNTOWN IMPROVEMENT PROJECT
PHASE II INTERSECTIONS
MANCHESTER BY THE SEA, MA**

SCOPE OF WORK

The work under this Contract consists of Complete Streets intersection improvements - such as curb extensions and sidewalk bump outs, relocated crosswalks, and reallocation of on-street parking - at three separate intersections in Manchester-by-the-Sea, MA.

Project Location #1 is the intersection of Central Street, Union Street, School Street, and Church Street. Project Location #2 is the intersection of Beach Street and Union Street. Project Location #3 is the intersections of Summer Street, Sea Street, and Washington Street. The work includes sidewalks, wheelchair ramps, driveways, pavement micromilling and overlay, unclassified excavation, drainage, granite curb, pavement markings, signs, landscaping and other incidental work.

The location and character of the work are shown on the Contract Drawings.

The work is to be constructed in accordance with said plans as such further working detailed plans and/or sketches as may be furnished from time to time by the Engineer and Designer. Details shown on said plans are indicative of the types of structures required and are subject to revision, alteration, modification, and variation. Such revisions, alterations, modifications, and variations in said plans as desirable in the opinion of the Engineer and Designer, on account of conditions encountered or for other reasons, shall not be considered a variation of term of this contract, and the assent of the surety on the bond accompanying this contract to such revisions, alterations, modifications, or variations shall not be required.

All said plans, general and detail, and the specifications are to be considered together so that any work shown on the plans, though not mentioned in the specifications, and any work mentioned in the specifications, though not shown on the plans, is to be executed by the Contractor as part of the performance of this contract. Figured dimensions are to prevail over scale.

STANDARD SPECIFICATIONS

All work under this contract shall be done in conformance with the Standard Specifications for Highways and Bridges dated 1988, the Supplemental Specifications dated March 1, 2019, and the Interim Supplemental Specifications dated September 30, 2018 ; the 2017 Construction Standard Details, the 1990 Standard Drawings for Signs and Supports; the 2009 Manual on Uniform Traffic Control Devices (MUTCD) with Massachusetts Amendments; the Plans and these Special Provisions.

The General Conditions, Supplementary Conditions and Special Provisions shall take precedence over the General Requirements of Division I of the Standard Specifications.

The words “Standard Specifications” as used in these Specifications refer to the “Massachusetts Department of Public Works, Standard Specifications for Highways and Bridges, 1988 Edition,” including all supplemental specifications and addenda thereto. (The Massachusetts Department of Public Works is that state agency also formerly known as the Massachusetts Highway Department, MassHighway, or MHD, and is now known as the Massachusetts Department of Transportation, or MassDOT). These Standard Specifications are herein incorporated by reference for materials and/or procedures, unless superseded, altered, or amended by these Specifications. Also incorporated by reference herein are the “Construction and Traffic Standard Details” of the same state agency.

The Standard Specifications, and/or other referenced standards, are referenced for materials, testing, and/or procedures only. Payments will be as specified under “Basis of Payment” as determined under “Method of Measurement” of the appropriate items included in these Specifications.

All said Plans, general and detail, and the Specifications shall be considered together so that any work shown on the Plans, though not mentioned in the Specifications, and any work mentioned in the Specifications, though not shown on the Plans, is to be executed by the Contractor as part of the performance of this Contract. Figured dimensions shall prevail over scale. All things, which in the opinion of the Engineer and Designer inferred from the Plans, shall be executed by the Contractor as part of the Contract, and the Engineer and Designer shall be the sole judge as to whether the detail plans conform to the general plans.

MASSHIGHWAY TO MASSDOT NAME CHANGE

The following definitions in Section 100 of the Standard Specifications for Highways and Bridges are revised as follows:

(Amend definition of Department)

1.17 –DepartmentEffective November 1, 2009, St. 2009, c. 25 abolishes the Massachusetts Department of Highways and all assets, liabilities, and obligations become those of the Massachusetts Department of Transportation (“MassDOT”). Anywhere in this contract the terms Commission, Commonwealth, Department of Public Works, Department, Massachusetts Highway Department, MassHighway, Party of the First Part, or any other term intending to mean the former Massachusetts Department of Highways is used, it shall be interpreted to mean MassDOT or applicable employee of MassDOT unless the context clearly requires otherwise. Furthermore, MassDOT by operation of law inherited all rights and obligations pursuant to any contract, and therefore parties to this contract hereby acknowledge and agree that its terms shall be liberally construed and interpreted to maintain the rights and obligations of MassDOT. Furthermore, the parties hereby acknowledge and agree that the transfer of all rights and obligations from the Massachusetts Department of Highways to MassDOT shall not have the effect of altering or eliminating any provision of this contract in a manner that inures to the detriment of MassDOT.

(Add a definition for MassDOT)

1.46 – MassDOT.....The Massachusetts Department of Transportation, a body politic and corporate, under St. 2009, c. 25 “An Act Modernizing the Transportation Systems of the Commonwealth”, as amended.

ACCESS MASSDOT HIGHWAY INFORMATION ON WEBSITE

Access MassDOT Highway Information related to Construction, Design/Engineering, Contractor/Vendor Information, Approved Materials and Fabricators, Manuals, Publications and Forms at:

<http://www.mass.gov/massdot/highway>

Select Doing business with us

PERSONAL PROTECTIVE SAFETY EQUIPMENT FOR CONTRACTOR PERSONNEL

The Contractor is responsible to ensure that all personnel, including all subcontractors, working on the project are issued and are wearing all necessary personal protective safety equipment while working within the project limits. This equipment shall include, as a minimum, a hardhat and a safety vest, regardless of the type of work being performed. Other safety equipment shall be added as required to perform the work in which they are engaged and in accordance with all local, state and federal requirements in effect. Safety equipment shall be provided at no additional cost to the Department.

PROTECTION OF UNDERGROUND FACILITIES

The Contractor's attention is directed to the necessity of making his/her own investigation in order to assure that no damage to existing structures, drainage lines, traffic signal conduits, etcetera, will occur.

The Contractor shall notify Massachusetts DIG SAFE and procure a Dig Safe Number for each location prior to disturbing existing ground in any way. The telephone number of the Dig Safe Call Center is 1-888-344-7233.

WORK SCHEDULE

The Contractor is to prosecute construction during Daytime hours as defined below. Daytime refers to the period from 8:00 a.m. to 4:00 p.m. local time daily, except Sundays and legal holidays. No work outside the above listed hours will be permitted except upon express written permission by the Engineer. No work that will disrupt travel on the existing roadways (lane closures, lane shifts, trenching, etc.) shall be done from 6:00AM to 9:00AM and from 3:00PM to 6:00PM. All work shall be coordinated with other Town projects, and/or other projects, in the vicinity.

The Contractor shall be required to submit to the Engineer, for approval, a schedule of operations by means of the Critical Path Method, or other approved method, of the proposed construction schedule within ten calendar days after Notice-to-Proceed. Approval of the Contractor's schedule of operations by the Engineer does not relieve the Contractor from the responsibility of completing the work within the time specified. It is assumed that the Contractor has the required means to perform the specified work within the specified time frame.

No work shall be allowed on holidays or on dates of special events, including, but not limited to, the following:

- Memorial Day
- 4 July, Independence Day
- Labor Day
- Day before Thanksgiving Day
- Thanksgiving Day
- Day before Christmas Day
- Christmas Day
- Day before New Year's Day
- New Year's Day

Written requests to work on any State Holiday shall be submitted fifteen days in advance to the Engineer for approval.

PLANS

(Supplementing Subsection 5.02)

The Contractor shall furnish Mylar "AS BUILT" plans of the completed project to the Engineer. These "AS BUILT" plans shall be furnished prior to the date of final acceptance. Full compensation for these plans shall be included in the prices bid for the various Contract items of work and no additional compensation will be allowed therefore.

The Engineer will make the original drawings available to the Contractor for use in preparing the as-built drawings. However, the Contractor may request a CADD version of the contract drawings as an alternative method for preparing the "AS BUILT" plans. In either case, final "AS BUILT" plans shall contain all information shown on the contract drawings and shall clearly indicate areas where changes were made during construction.

The “AS BUILT” plans shall be titled “AS BUILT” and stamped and dated by a Professional Engineer registered in the Commonwealth of Massachusetts. The Professional Engineer’s stamp is required to certify any changes made to the contract drawings and shall not dictate responsibility for the original design drawings.

The “AS BUILT” plans will provide a record of constructed improvements for future reference, therefore partial plan sets will not be accepted. The Contractor may elect to use a combination of reproducible duplicates of the design drawings and revised CAD drawings to provide a complete set of “AS BUILT” plans.

COOPERATION OF THE CONTRACTOR
(Supplementing Subsections 5.05 and 5.06)

Agents of various public service agencies, municipal and State Departments, and private site contractors may be entering on the work site to remove existing utilities, to construct or place new facilities or to make alterations to existing facilities.

The Contractor shall perform the work in cooperation with the various agencies in a manner which causes the least interference with the operations of the aforementioned agencies and shall have no claim for delay which may be due, or result, from said work of these agents.

CONSTRUCTION STAKING
(Supplementing Subsection 5.07)

The Contractor will be furnished information and ties for the survey baseline and benchmarks. The Contractor shall perform all survey required for the work.

PUBLIC SAFETY AND CONVENIENCE
(Supplementing Subsection 7.09)

The Contractor shall provide necessary access for fire apparatus and other emergency vehicles through the work zones to abutting properties at all times.

Sweeping and cleaning of surfaces beyond the limits of the project required to clean up material caused by spillage or vehicular tracking during the various phases of the work shall be considered as incidental to the work being performed under the Contract and there will be no additional compensation.

NOTICE TO OWNERS OF UTILITIES
(Supplementing Subsection 7.13)

Written notice shall be given by the Contractor to all public service corporations or municipal and State officials owning or having charge of publicly or privately owned utilities at least one week in advance of the commencement of operations that will affect the utilities. The Contractor shall, at the same time, file a copy of such notice with the Engineer.

Before commencing work on service connections, the Contractor shall be responsible for contacting the Electric Company servicing the area to obtain construction requirements, standards, and to give adequate notice of commencement of work. The Contractor's attention is further directed to the requirements of Work in the Immediate Vicinity of Certain Underground Structures and Poles herein included in these Special Provisions.

The following are the names of owners and representatives of the principal utilities affected, but completeness of this list is not guaranteed by the Department:

TOWN OF MANCHESTER-BY-THE-SEA

Public Works
10 Central Street
Manchester-by-the-Sea, MA 01944

Chuck Dam
Public Works Director
Phone:(978) 526-1242

Fire Department
12 School Street
Manchester-by-the-Sea, MA 01944

Int. Chief Albert Beardsley
Phone:(978) 526-4040

Police Department
10 Central Street
Manchester-by-the-Sea, MA 01944

Chief Edward G. Conley
Phone:(978) 526-1212

ELECTRIC

National Grid
548 Haydenville Road
Leeds, MA 01053

Sandra Annis
Phone:(413) 582-7424

TELEPHONE

Verizon
385 Myles Standish Blvd.
Taunton, MA 02780

Karen Mealey
Phone: (774) 409-3160

GAS

National Grid
40 Sylvan Road-3rd Floor
Waltham, MA 02451

Melissa Owens
Phone: (781) 907-2845

CABLE

Comcast Cable Corporation
PO Box 6505, 5 Omni Way
Chelmsford, MA 01824

Wendy Brown
Phone: (978) 848-5163

OTHER AFFECTED PARTIES ARE:

Vanasse Hangen Brustlin, Inc.
101 Walnut Street
Watertown, MA 02471-9151

Patricia G. Domigan
Project Manager
617) 924-1770

The Contractor shall make his/her own investigation to assure that no damage to existing structures, drainage lines, traffic signal conduits, and other utilities will occur as a result of construction operations.

The Contractor shall notify "Mass. DIG SAFE" and procure a DIG SAFE number of each location prior to disturbing ground in any way.

"DIG-SAFE" Call Center: Telephone 1-888-344-7233

PROTECTION OF UTILITIES AND PROPERTY
(Supplementing Subsection 7.13)

The Contractor, in constructing or installing facilities alongside or near sewers, drains, water or gas pipes, electric or telephone conduits, poles, sidewalks, walls, vaults or other structures shall sustain them securely in place. The Contractor shall coordinate with the officers and agents of the various utility companies and municipal departments to assure that the services of these structures are maintained. The Contractor shall also be responsible for the repair or replacement, at no additional cost to the Owner (Department), of any damage to such structures caused by construction operations. The Contractor is responsible to leave them in the same condition as they existed prior to commencement of the work. In case of damage to utilities, the Contractor shall promptly notify the utility owner and shall, if requested by the Engineer, furnish labor and equipment to work temporarily under the utility owner's direction. Pipes or other structures damaged by the operation of the Contractor may be repaired by the Department or by the utility owner which suffers the loss. The cost of such repairs shall be borne by the Contractor, without compensation therefor.

If during construction there is an existing utility and/ or structure found to be in conflict with the proposed work under this Contract, the Contractor shall protect and maintain the services to the utilities and structures. The Engineer will, as soon as possible identify the utilities to be relocated or other such activities deemed suitable for resolution.

If live service connections are to be interrupted by excavations of any kind, the Contractor shall not break the service until new services are provided. Abandoned services shall be plugged off or otherwise made secure.

Full compensation for furnishing all labor, materials, tools, equipment and incidentals for doing all the work involved in protecting or repairing property as specified in this Section, shall be considered included in the prices paid for the various Contract items of work and no additional compensation will be allowed therefor.

WORK IN THE IMMEDIATE VICINITY OF CERTAIN UNDERGROUND STRUCTURES AND UTILITY POLES

For overhead connections, the Electric Company servicing the area will make the connection from the top of the riser on the utility pole to the power source. The Contractor shall supply all labor, materials and equipment to install the service connection, complete in place and in accordance with the Electric Company procedures, from the controller to and including the riser with enough wire coiled above the riser to permit the Electric Company servicing the area to make the final connection.

For underground connections, the Electric Company servicing the area will perform the actual wiring of the service connections from its power source to the sweep at the local controllers, but all steel sweeps, ducts, entrance holes into manholes, patching and all other necessary labor, materials and equipment required to install the electric service, complete in place, shall be furnished by the Contractor.

The Contractor shall pay the Electric Company servicing the area for their services rendered for the connection of overhead and underground service connections.

Before starting work at existing manholes, the Contractor shall test for gas and blow out the manholes.

TEMPORARY ACCESS TO AREA MERCHANTS AND BUSINESSES **(Supplementing Subsections 8.02 and 8.06)**

The work is in a predominantly residential, retail and commercial business section of the Town and access to all properties must be maintained at all times.

The Contractor shall provide safe and ready means of ingress and egress to all stores and shops, public and private and professional offices and any other businesses or residences in the project area, both day and night, for the duration of the project.

SAFETY CONTROLS FOR CONSTRUCTION OPERATIONS
(Supplementing Subsection 850.21 AND 850.61)

Safety controls for construction operations shall be done in accordance with the relevant provisions of Section 850 of the Standard Specifications, the Manual on Uniform Traffic Control Devices, the Traffic Management Plan and the following:

The providing of safety controls for construction operations shall be considered incidental to this contract and the costs for safety controls shall be included in the unit bid price for those contract items requiring such controls.

Positioning, adjusting and re-positioning of all devices such as traffic cones, high level warning devices, etc., not otherwise classified and paid for under other items in this contract, is considered incidental and no separate payment will be made.

WORK DONE BY OTHERS

Relocation and/or resetting to new grades of all private utilities, including utility poles, made necessary by the construction of this project, will be accomplished by the respective utility companies.

MATERIAL REMOVED AND STACKED

The Contractor shall carefully remove, transport and stack all material that, in the opinion of the Engineer, is salvageable. The material shall be stacked at a location designated by the Engineer/Owner and/or the Town of Manchester by the Sea. The Contractor shall coordinate with the Town of Manchester by the Sea to schedule drop-off time and location.

DISPOSAL OF SURPLUS MATERIAL

Surplus materials obtained from any type of excavation, and all existing and other materials not required to be removed and stacked or needed for use on the project, as determined by the Engineer, shall become the property of the Contractor and disposed of subject to the regulations and requirements of local authorities governing the disposal of such materials, at no additional compensation.

DRAINAGE

All drainage castings in new pavement areas shall be installed at base or binder course grade, as directed by the Engineer, and reset to proposed finish surface grade prior to placement of the pavement surface course.

All pipes and structures installed as part of this Contract shall be left in a clean and operable condition at the completion of the work.

All existing pipes to be abandoned shall be plugged with brick masonry not less than 8 inches in thickness in conformance with the Standard Specifications, Section 201.62.

No separate payment will be made for the maintenance of the existing drainage system or for plugging of pipes, but all costs in connection therewith shall be included in the unit prices bid for the various Contract items.

DRAINAGE STRUCTURES

Where new pipe is shown on the drawings to be connected into an existing drainage structure to remain, the existing structure shall be first cleaned to remove all mud, debris and other material. The existing structure wall shall be carefully and neatly cut to provide the minimum size opening required for the insertion of the new pipe. The proposed pipe end shall be set or cut off flush with the inside face of the existing structure wall and the remaining space around the pipe completely filled with cement grout for the full thickness of the structure wall.

Existing shaped inverts shall be reconstructed as necessary to provide a smooth and uniform flow channel from the new pipe through the existing structure.

No separate payment will be made for the cost of connecting new pipes into existing structures, cleaning and necessary alterations of existing structures, but all costs in connection therewith shall be included in the unit prices bid for the various pipe items.

SAWCUTS

Existing pavements to remain shall be sawcut at all openings for utility work, for new or reset curb and at all joints with proposed full-depth hot mix asphalt pavement, as shown on the plans and as directed by the Engineer.

PROPERTY BOUNDS

The Contractor shall exercise due care when working around all property bounds which are to remain. Should any damage to a bound result from the actions of the Contractor, the bound shall be replaced and/or realigned by the Contractor as directed by the Engineer at no cost to the Owner.

ARCHITECTURAL ACCESS BOARD TOLERANCES

The Contractor is hereby notified that they are ultimately responsible for constructing all project elements in strict compliance with the current AAB/ADA rules, regulations and standards.

All construction elements in this project associated with sidewalks, walkways, wheelchair ramps and curb cuts are controlled by 521CMR – Rules and Regulations of the Architectural Access Board.

The AAB Rules and Regulations specify maximum slopes and minimum dimensions required for construction acceptance. There is no tolerance allowed for slopes greater than the maximum slope nor for dimensions less than the minimum dimensions.

Contractors shall establish grade elevations at all wheelchair ramp locations, and shall set transition lengths according to the appropriate table in the Construction Standards (or to the details shown on the plans).

All wheelchair ramp joints and transition sections which define grade changes shall be formed, staked and checked prior to placing cement concrete. All grade changes are to be made at joints.

ASPHALT BINDER

In order to allow an efficient transition from viscosity graded Asphalt Cement (AC) specifications to performance graded Superpave Binder (PG) specifications (non-modified binder), the Massachusetts Department of Transportation is replacing AC graded products with PG binder as follows:

Projects requiring AC-20 will be constructed using PG 64-28

Projects requiring AC-5 will be constructed using PG 52-34

The Contractor shall follow existing mix design requirements and produce the hot-mix using the required grade of PG binder.

The binder supplier shall provide the Department with PG test results and a certification of the PG binder grade when PG binder is substituted for AC grade asphalt. This testing and certification shall be based on the existing lot numbering system.

The binder supplier shall not mix AC and PG binders in the same tank, unless tested and re-certified to meet the specified grade.

Performance-Graded asphalt shall not have a higher temperature grade than specified without prior approval.

RESTRICTED MATERIALS

All new construction materials shall be asbestos-free including any roofing felt, adhesives, waterproofing materials, grout, or sealer that may be used in project construction.

All yellow temporary and permanent pavement markings, including all pavement marking tape, placed as part of this project shall be lead-free.

ORDER OF CONDITIONS

The Contractor is advised that an Order of Conditions has not been issued for this project.

ITEM 102.51**INDIVIDUAL TREE PROTECTION****EACH**

The work under these items shall conform to the relevant provisions of Sections 101, 644 and 771 and the following:

The purpose of these items is to prevent damage to branches, stems and root systems of existing individual trees as well as shrubs and other quality vegetation to remain, and to ensure their survival. To the extent possible, to avoid soil compaction within the root zone, construction activities including, but not limited to, vehicle movement, excavation, embankment, staging and storage of materials or equipment shall not occur underneath the canopy (drip line) of trees to remain. Where these activities will occur within 10 feet of the canopy of trees or where directed, the Contractor shall take the appropriate protective measures specified herein.

Individual Tree Protection, Item 102.51, shall be used when construction activities are likely to occur within the canopy of individual trees or where there may be any risk of damage to trees.

The Contractor shall be solely responsible for judging the full extent of the work requirements, including, but not necessarily limited to any equipment and materials necessary for providing tree protection.

Incidental to the cost of these items, the Contractor shall retain the services of a certified arborist, who shall make recommendations as to the specific appropriate treatment of trees within or near the work zone.

Prior to any construction activities, the Contractor and Arborist shall walk the site with the Engineer and Town Tree Warden to identify which trees will require protection and to determine approved measures. The Arborist shall make recommendations as to appropriate methods to trees. The Engineer will have final decision as to trees and methods.

The Contractor is responsible for the protection of all existing trees and plants within and immediately adjacent to the construction area that are not designated to be removed for the length of the construction period.

SUBMITTALS

Incidental to this item, the Contractor shall provide to the Engineer one (1) copy American National Standards Institute (ANSI) Standard Z-133.1 and A300 Standard Practices for Tree, Shrub, and Other Woody Plant Maintenance, Part 1: Pruning. These references shall be kept by the Engineer at his office for the length of the Contract.

Prior to start of work, the Contractor shall submit to the Engineer the name and certification number of the Massachusetts Certified Arborist referenced herein. Cost for Certified Arborist for all activities pertaining to this Item shall be incidental to this item.

MATERIALS

Fence and temporary fence posts shall be subject to the approval of the Engineer.

Fencing for individual plants shall be polyethylene fencing or chain link fence (new or used).

Staking for individual tree protection fencing shall be steel posts or 2x4 lumber as directed and approved by the Engineer.

Wood chips shall conform to provisions of Wood Chip Mulch under Materials Section M6.04.3.

Trunk protection shall be 2x4 cladding, at least 8 feet in length, clad together with wire. Alternative materials shall be at the approval of the Engineer. Alternative materials shall provide adequate protection from anticipated construction activities and shall not injure or scar trunk. Trunk protection shall include burlap to separate trunk cladding from bark.

Incidental to these items, the Contractor shall provide water for maintaining plants in the construction area that will have exposed root systems for any period during construction.

CONSTRUCTION METHODS

To the extent possible, to avoid soil compaction within the root zone, construction activities including, but not limited to, vehicle movement, excavation, embankment, staging and storage of materials or equipment shall not occur underneath the canopy (drip line) of trees to remain. Where these activities will occur within 10 feet of the canopy of trees, the Contractor shall provide Individual Tree Protection as specified herein.

For individual tree protection, the Contractor shall set posts and fencing at the limits of the tree canopy. Where construction activities closer to the trees is unavoidable, the contractor shall tie branches out of the way and place wood chips to a depth of 6 inches on the ground to protect the root systems. The Contractor shall wrap the area of the trunk of the tree with burlap prior to armoring with 2x4 cladding. Cladding for tree trunks shall extend from the base of the tree to at least 8 feet from the base.

To the extent possible, temporary landscaped fencing shall be installed at the limit of tree canopy and shall be staked and maintained vertical for the length of the contract.

Where excavation within canopy is unavoidable, the Contractor shall use equipment and methods that shall minimize damage to the tree roots, per recommendations of the Certified Arborist. Such methods may require root pruning prior to, as well as during, any excavation activities.

All fencing, trunk protection, branch protection, and woodchips shall be maintained throughout the duration of the contract. Protective fencing shall be repaired and woodchip mulch replaced as necessary during the duration of the contract at no additional cost.

Cutting and Pruning

Some pruning of roots and branches may be a necessary part of construction. Pruning will be performed on the same side of the tree that roots have been severed.

The Contractor shall retain the services of a Massachusetts State Certified Arborist to oversee any cutting of limbs, stem or roots of existing trees. All cuts shall be clean and executed with an approved tool. Under no circumstances shall excavation in the tree protection area be made with mechanical equipment that might damage the existing root systems.

Any tree root area exposed by construction shall be covered and watered immediately. Exposed tree roots shall be protected by dampened burlap at all times until they can be covered with soil.

Watering

Water each tree within the construction area where work is in progress twice per week until the surrounding soil of each tree is saturated for the duration of construction activities.

Removal of Protection

After all other construction activities are complete, but prior to final seeding, wood chips, temporary fencing, branch protection, and trunk protection materials shall be removed and disposed off site by the Contractor at no additional cost.

Tree Damage

The Contractor shall be held responsible for the health and survival of the existing trees in the immediate vicinity of the of the construction area. Damage that, in the Engineer's opinion, can be remedied by corrective measures shall be repaired immediately. Broken limbs shall be pruned according to industry standards. Wounds shall not be painted. Trees or shrubs that are damaged irreparably shall, at the Engineer's discretion, be replaced per the requirements of Division I of these Special Provisions. Cost of replacement trees shall be borne by the Contractor.

COMPENSATION

Where the plans show specific, individual trees to remain and where grading or other disturbance is shown within the drip line of these trees or where the Engineer determines that an individual tree must be protected, these trees shall be protected and paid for under Item 102.51 Individual Tree Protection per each tree protected.

Where the plans show specific, individual trees to remain and where grading or other disturbance is shown within the drip line of these trees or where the Engineer determines that an individual tree must be protected, these trees shall be protected and paid for under Item 102.51, Individual Tree Protection.

Payment under these items shall be scheduled throughout the length of contract: 30 percent of value shall be paid upon installation, 30 percent approximately halfway through the contract, and the remainder to be paid at the end of the contract after completion of construction operations that would disturb plants and after the protection materials have been removed and properly disposed of off-site by the Contractor.

Compensation for Individual Tree Protection will be paid for at the contract unit price per each under Item 102.51. This item shall include full compensation for all labor, equipment, materials, and incidentals for the satisfactory completion of the work, including the services of a certified arborist, water and fertilizer, and the subsequent removal and satisfactory disposal of the protective materials upon completion of the contract.

Cost of wood chips, as required, shall be incidental to these items.

ITEM 222.3 FRAME AND GRATE (OR COVER) MUNICIPAL STANDARD EACH
ITEM 223.1 FRAME AND GRATE (OR COVER) REMOVED AND STACKED EACH

The work under these items shall conform to the relevant provisions of Section 201 and 220 of the Standard Specifications and the following:

New catch basin castings shall meet Town of Manchester by the Sea standards. Provide three flange frames at curb inlet locations. 6 Inch heavy duty frames and grates shall be provided at all inlets.

All castings indicated on the Contract Drawings to be removed and stacked shall be stacked on site. The Contractor shall coordinate with the Town to schedule drop-off time and location for all stacked items.

ITEM 238.10**10 INCH DUCTILE IRON PIPE****FT**

The work under these items shall conform to the relevant provisions of Section 230 of the Standard Specifications and the following:

The contract unit price per linear foot of Item 238.10 shall include all costs for any Class B Trench excavation, Control Density Fill, Gravel Borrow Type C, or Crushed Stone required for the complete installation of 10 Inch Ductile Iron Pipe. These items shall be considered incidental to item 238.10 and separate payment shall be made for these trenching, bedding, and backfilling items, regardless of trench depth. Pavement patching shall be paid for under item 451. HMA for Patching.

Controlled density fill shall conform to the requirements of Section M4.08.0 Type 1E.

ITEM 415.**PAVEMENT MICROMILLING****SQUARE YARD**

Item 415 – Pavement Micromilling shall conform to the same requirements for Section 130 Pavement Milling within Section 450.

Description**415.20 General.**

This work shall consist of micromilling and removal of existing Hot Mix Asphalt (HMA) pavement courses from the project by the Contractor. Micromilling shall be performed in conformity with the approved QC Plan. The Contractor shall present and discuss in sufficient detail the Quality Control information and activities related to milling at the Construction Quality Meeting required under Section 450. Unless otherwise specified, the milled material shall become the property of the Contractor.

Construction Procedures**415.60 General.**

All construction procedures under Pavement Micromilling shall also conform to any of the following relevant provisions of Pavement Milling:

Milling Equipment Requirements.

The milling equipment shall be self-propelled with sufficient power, traction, and stability to remove the existing HMA pavement to the specified depth and cross-slope. The milling machine shall be capable of operating at a minimum speed of 10 feet (3 meters) per minute, designed so that the operator can at all times observe the milling operation without leaving the control area of the machine, and equipped with the following:

- (a) A built in automatic grade control system that can control the longitudinal profile and the transverse cross-slope to produce the specified results.
- (b) Longitudinal controls capable of operating from any longitudinal grade reference, including string line, 30 foot (10 meter) ski minimum, 30 foot (10 meter) mobile string line minimum, or a matching shoe.
- (c) The transverse controls shall have an automatic system for controlling cross-slope at a given rate.
- (d) Cutting heads able to provide a minimum 6 foot (2 meter) cutting width and a 0 to 4 inch (0 to 100 mm) deep cut in one pass. The teeth on the revolving cutting drum must be

ITEM 415. (Continued)

continually maintained and shall be replaced as warranted to provide a uniform pavement texture.

- (e) An integral pickup and conveying device to immediately remove milled material from the roadway and discharge the millings into a truck, all in one operation.
- (f) All necessary safety devices such as reflectors, headlights, taillights, flashing lights and back up signals so as to operate safely in both day and night.
- (g) A means of effectively limiting the amount of dust escaping from the milling and removal operation in accordance with local, State, and Federal air pollution control laws and regulations.

When milling smaller areas or areas where it is impractical to use the above described equipment, the use of a smaller or lesser-equipped milling machine may be permitted when approved by the Engineer.

Sweeper Equipment Requirements.

The Contractor shall provide a sufficient number of mechanical sweepers to ensure that the milled surface is free of millings and debris at the end of each day's milling operations. Each sweeper shall be equipped with a water tank, spray assembly to control dust, a pick-up broom, a dual gutter broom, and a dirt hopper. The sweepers shall be capable of removing millings and loose debris from the textured pavement.

Milling Operations.

The milling operations shall be scheduled to minimize the duration and placement of traffic on the milled surface. Under no circumstances shall the milled surface be left exposed to traffic for a period exceeding seven days. The Engineer may allow the Contractor to adjust the above limitations on milling production when necessary.

The Contractor shall coordinate milling and paving operations to minimize the exposure of milled surfaces to traffic. The Contractor shall ensure that milled surfaces are overlaid in a timely manner to avoid damage to the pavement structure. Any damage to the pavement structure resulting from extended exposure of the milled surface to traffic shall be repaired as directed by the Engineer at the Contractor's expense.

The existing pavement shall be removed to the average depth shown on the plans, in a manner that will restore the pavement surface to a uniform cross-section and longitudinal profile. The longitudinal profile of the milled surface shall be established using a 30 foot (10 meter) mobile ski, mobile string line, or stationary string line. The cross-slope of the milled surface shall be

ITEM 415. (Continued)

established by a second sensing device or by an automatic cross-slope control mechanism. The Contractor will be responsible for providing all grades necessary to remove the material to the proper line, grade, cross section, superelevation, and transitions shown on the plans or as directed by the Engineer. The requirement for automatic grade or slope controls may be waived by the Engineer in locations warranted by the situation, including intersections and closely confined areas.

The Engineer may adjust the average milling depth specified on the plans by $\pm 3/4"$ ($\pm 20\text{mm}$) during each milling pass at no additional payment to minimize delamination of the underlying pavement course or to otherwise provide a more stable surface. If delamination or exposure of concrete occurs when milling a HMA pavement course from an underlying Portland Cement Concrete (PCC) pavement, the Contractor shall cease milling operations and consult the Engineer to determine whether to reduce the milling depth or make other adjustments to the operation.

Protection of Inlets and Utilities.

Throughout the milling operation, protection shall be provided around existing catch basin inlets, manholes, utility valve boxes, and any similar structures. Any damage to such structures as a result of the milling operation is the Contractor's responsibility and shall be repaired at the Contractor's expense. To prevent the infiltration of milled material into the storm sewer system the Contractor shall take special care to prevent the milled material from falling into the inlet openings or inlet grates. Any milled material that falls into inlet openings or inlet grates shall be removed at the Contractor's expense.

Vertical Faces.

All permanent limits of the milled area shall be sawcut or otherwise neatly cut by mechanical means to provide a clean and sound vertical face. No vertical faces, transverse or longitudinal, shall be left exposed to traffic. If any vertical face is formed in an area exposed to traffic a temporary paved transition with a maximum 12:1 slope shall be established. If the milling machine is used to temporarily transition the milled pavement surface to the existing pavement surface, the temporary transition shall be constructed at a maximum 12:1 slope.

Opening to Traffic.

Prior to opening a milled area to traffic, the milled surface shall be thoroughly swept with a mechanical sweeper to remove all remaining millings and dust. This operation shall be conducted in a manner so as to minimize the potential for creation of a traffic hazard and to comply with local, State, and Federal air pollution control laws and regulations. Any damage to vehicular traffic as a result of milled material becoming airborne is the responsibility of the Contractor and shall be repaired at the Contractor's expense. Temporary pavement markings shall be placed in accordance with the provisions of Subsection 850.64.

ITEM 415. (Continued)

Milled Surface Inspection.

The milled surface shall provide a satisfactory riding surface with a uniform textured appearance. The milled surface shall be free from gouges, excessive longitudinal grooves and ridges, oil film, and other imperfections that are a result of defective equipment, non-uniform milling teeth, improper use of equipment, or otherwise poor workmanship. Any unsatisfactory surfaces produced shall be corrected by remilling at the Contractor's expense and to the satisfaction of the Engineer.

The Contractor shall perform Quality Control inspection of all work items addressed as specified in the table below. Inspection activities during milling of HMA pavement may be performed by qualified Production personnel (e.g. Skilled Laborers, Foremen, Superintendents). However, the Contractor's QC personnel shall have overall responsibility for QC inspection. The Contractor shall not rely on the results of Department Acceptance inspection for Quality Control purposes. The Engineer shall be provided the opportunity to monitor and witness all QC inspection.

The milled surface of each travel lane shall be divided into longitudinal Sublots of 500 feet (150 meters). The Contractor shall perform a minimum of one random QC measurement within each Sublot with a 10 foot (3 meter) straightedge in the transverse direction across the milled surface. Additional selective QC measurements within each Sublot will be performed as deemed necessary by the QC personnel. All QC inspection results shall be recorded on NETTCP Inspection Report Forms. The Engineer will also randomly inspect a minimum of 25% of the Sublots. The Contractor shall perform surface texture measurements with a 10 foot (3 meter) straightedge in the transverse direction across the milled surface. The milled surface shall have a texture such that the variation from the edge of the straightedge to the top of ridges between any two ridge contact points shall not exceed 1/8 inch (3 mm). The difference in height from the top of any ridge to the bottom of the groove adjacent to that ridge shall not exceed 1/16" (1.6 mm). Any point in the surface not meeting these requirements shall be corrected as directed by the Engineer at the Contractor's expense.

In isolated areas where surface delamination between existing HMA layers or a surface delamination of HMA on Portland Cement Concrete causes a non-uniform texture to occur, the straightedge surface measurement requirements stated in the preceding paragraph may be waived, subject to the approval of the Engineer.

ITEM 415. (Continued)

Minimum QC Inspection of Milling Operations

Inspection Component	Items Inspected	Minimum Inspection Frequency	Point of Inspection	Inspection Method
Equipment	As specified in QC Plan	Per QC Plan	Per QC Plan	Per QC Plan
Environmental Conditions	Protection of Inlets & Utilities	Per QC Plan	Existing Surface	Visual Check
	Removal of Millings & Dust	Per QC Plan	Milled Surface	Visual Check
Workmanship	Milling Depth	Per QC Plan	Milled Surface	Check Measurement
	Cross-Slope & Profile	Per QC Plan	Milled Surface	Check Measurement
	Milled Surface Texture	Per QC Plan	Milled Surface	Visual Check
	Milled Surface Roughness	Once per 500 feet(150 meters) per milled lane	Milled Surface per Subsection 410.67	10 foot (3 meter) standard straightedge
	Sawcut Limit Vertical Face	Per QC Plan	Sawcut Limits	Visual Check

415.61 Micromilling Equipment Requirements.

The micromilling machine shall be equipped with a drum specifically designed to provide the surface specified below.

415.62 Control Strip.

The Contractor shall micromill a control strip. The control strip shall be 100 feet minimum in length with a uniformly textured surface and cross slope, as approved by the Engineer.

The micromilled surface of the control strip shall provide a satisfactory riding surface with a uniform textured appearance. The micromilled surface shall be free from gouges, excessive longitudinal grooves and ridges, oil film, and other imperfections that are a result of defective equipment, non-uniform milling teeth, improper use of equipment, or otherwise poor workmanship. Any unsatisfactory surfaces produced in the control strip shall be corrected by additional micromilling at the Contractor's expense and to the satisfaction of the Engineer.

The micromilled pavement surface shall have a transverse pattern of 0.2 – 0.3 inch center to center of each strike area. The Contractor shall perform surface texture measurements with a 10 foot (3 meter) straightedge in the transverse direction across the milled surface. The milled

ITEM 415. (Continued)

surface shall have a texture such that the variation from the edge of the straightedge to the top of ridges between any two ridge contact points shall not exceed 1/8 inch (3 mm). The difference in height from the top of any ridge to the bottom of the groove adjacent to that ridge shall not exceed 1/16" (1.6 mm). Any point in the surface not meeting these requirements shall be corrected as directed by the Engineer at the Contractor's expense.

415.67 Micromilled Surface Inspection.

The Contractor shall perform Quality Control inspection of all work items addressed under Section 415. The Contractor shall not rely on the results of Department Acceptance inspection for Quality Control purposes.

The micromilled surface shall meet the requirements of 415.62.

Compensation

415.80 Method of Measurement.

Micromilling - Micromilling will be measured for payment by the number of square yards (square meters) of area from which the milling of existing HMA pavement has been completed and the work accepted. No area deductions will be made for minor unmilled areas such as catch basin inlets, manholes, utility boxes and any similar utility structures.

415.81 Basis of Payment.

Micromilling - Micromilling, removal and disposal of existing HMA pavement will be paid for at the contract unit price per square yard (square meter). This price shall include all equipment, tools, labor, and materials incidental thereto. No additional payments will be made for multiple passes with the milling machine to remove the existing HMA surface to the grade specified.

No separate payments will be made for: performing handwork removal of existing pavement and providing protection around catch basin inlets, manholes, utility valve boxes and any similar structures; repairing surface defects as a result of the Contractor's negligence; providing protection to underground utilities from the vibration of the milling operation; sawcutting micromilled limits; installing and removing any temporary transition; removing and disposing of millings; furnishing a sweeper and sweeping after milling. The costs for these items shall be included in the contract unit price for Pay Item 415., Pavement Micromilling.

415.82 Payment Items.

415.	Pavement Micromilling	Square Yard
------	-----------------------	-------------

ITEM 590.

CURB REMOVED AND STACKED

FT

The work under this item shall conform to the relevant provisions of Section 501 of the Standard Specifications and the following:

Existing granite curbing to be removed and not needed to be reset, shall be removed and stacked on site, unless, in the judgment of the Engineer, they are unsuitable for salvage. Unsuitable granite edging become the property of the Contractor and shall be disposed of off the site at no additional cost to the Town. The Contractor shall coordinate with the Town to schedule drop-off time and location for all stacked items.

METHOD OF MEASUREMENT AND BASIS OF PAYMENT

Items 590 will be measured and paid at the Contract unit price per foot, which shall include all labor, materials, equipment and incidental costs required to complete the work.

No separate payment will be made for disposal, storage, transporting and handling of edging to be removed, stacked and other incidental work, but all costs in connection therewith shall be included in the unit prices bid for this item.

ITEM 697.1**SILT SACK****EACH**

Work under this item shall conform to the relevant provisions of Sections 670 and 227 of the Standard Specifications and the following:

The work under this item includes the furnishing, installation, maintenance and removal of a reusable fabric sack to be installed in drainage structures for the protection of wetlands and other resource areas and the prevention of silt and sediment from the construction site from entering the storm water collection system. Devices shall be ACF Environmental (800)-448-3636; Reed & Graham, Inc. Geosynthetics (888)-381-0800; The BMP Store (800)-644-9223; or approved equal.

CONSTRUCTION

Silt sacks shall be installed in retained existing and proposed catch basins and drop inlets within the project limits and as required by the Resident Engineer.

The silt sack shall be as manufactured to fit the opening of the drainage structure under regular flow conditions, and shall be mounted under the grate. The insert shall be secured from the surface such that the grate can be removed without the insert discharging into the structure. The filter material shall be installed and maintained in accordance with the manufacturer's written literature and as directed by the Engineer.

Silt sacks shall remain in place until the placement of the pavement overlay or top course and the graded areas have become permanently stabilized by vegetative growth. All materials used for the filter fabric will become the property of the Contractor and shall be removed from the site.

The Contractor shall inspect the condition of silt sacks after each rainstorm and during major rain events. Silt sacks shall be cleaned periodically to remove and disposed of accumulated debris as required. Silt sacks, which become damaged during construction operations, shall be repaired or replaced immediately at no additional cost to the Department.

When emptying the silt sack, the contractor shall take all due care to prevent sediment from entering the structure. Any silt or other debris found in the drainage system at the end of construction shall be removed at the Contractors expense. The silt and sediment from the silt sack shall be legally disposed of offsite. Under no condition shall silt and sediment from the insert be deposited on site and used in construction.

All curb openings shall be blocked to prevent stormwater from bypassing the device.

All debris accumulated in silt sacks shall be handled and disposed of as described in Section 227.

COMPENSATION

Silt sacks will be measured and paid at the Contract unit price per each, complete in place, which price shall include all labor, materials, equipment and incidental costs required to complete the work. No separate payment will be made for removal and disposal of the sediment from the insert, but all costs in connection therewith shall be included in the Contract unit price bid.

ITEM 701.2**CEMENT CONCRETE WHEELCHAIR RAMP****SY**

The work under these items shall conform to the relevant provisions of Section 701 of the Standard Specifications and the following:

Cement concrete wheelchair ramps shall be constructed at locations shown on the Plans and in conformance with the Architectural Access Board's Rules and Regulations dated February 23, 1996, as amended and the MassDOT Wheelchair Ramp Standards, as shown in the 2017 MassDOT Construction Standard Details.

Concrete score lines as specified in Section 701 shall be continuous throughout the wheelchair ramps.

Detectable tactile warning surface shall conform to the requirements of MassDOT Department as shown on MassDOT Construction Standard E 107.6.5 dated December 2017.

Warning surface shall be brick red in color.

No separate payment will be made for the detectable warning panels, but all costs in connection therewith shall be included in the unit price bid for Item 701.2.

ITEM 702.
ITEM 703.

HOT MIX ASPHALT WALK SURFACE
HOT MIX ASPHALT DRIVEWAY

TON
TON

The work under this item shall conform to the relevant provisions of Sections 701 and 450 of the Standard Specifications and to the following:

Surface course and intermediate course materials for Items 702 and 703 shall be as indicated on the Contract Drawings. All pavement courses shall be compacted to the final thickness as indicated on the Contract Drawings.

All Superpave HMA mixtures under this item shall be either 50 or 65 gyration mixtures. This item shall not be subject to the Quality Assurance requirements of Section 450 Hot Mix Asphalt Pavement.

Measurement and Payment

Items 702. and 703. will be measured and paid as per Subsections 701.80 and 701.81.

ITEM 850.

TEMPORARY TRAFFIC CONTROL

LUMP SUM

The work under this item shall conform to the relevant provisions of Section 850 of the Standard Specifications and the following:

This work shall consist of establishing and maintaining all traffic control measures to protect the traveling public, including bicyclists and pedestrians, and construction operations, including accessibility measures to protect pedestrians and assist pedestrians of all abilities traveling through and within the project limits.

SITE-SPECIFIC TRAFFIC CONTROL PLAN

The Contract Plans provide typical details and relevant notes for establishing and maintaining traffic control measures throughout construction. The Contractor shall prepare a Site-Specific Traffic Control Plan that is in substantial conformance with the details and notes shown on the Contract Plans, the latest Manual on Uniform Traffic Control Devices (MUTCD) with Massachusetts Amendments, and the latest MassDOT Traffic Management Plans and Detail Drawings. The plan shall accommodate vehicles, bicycles, pedestrians, and emergency services and shall include a detailed layout of all temporary signs, pavement markings, channelizing devices, portable message boards, arrow boards, and other devices to provide complete management of traffic. Any signs not included in the FHWA Standard Highway Signs book shall include sign face dimensions and layout details.

The Site-Specific Traffic Control Plan shall be stamped by a licensed Professional Engineer in the State of Massachusetts and shall be submitted to the Town for review. The Contractor shall allow at least two (2) weeks for review and acceptance by the Town. Modifications to the accepted Site-Specific Traffic Control Plan for vehicles or pedestrians shall be submitted to the Engineer at least two (2) weeks prior to the implementation of the change.

MAINTENANCE OF PEDESTRIAN TRAFFIC

The Contractor shall provide measures that establish and maintain Temporary Pedestrian Access Routes (TPAR) through the work zones in compliance with the most current Americans with Disabilities Act Accessibility Guidelines (ADAAG) and Public Right of Way Accessibility Guidelines (PROWAG). The various devices and/or features shall be installed in a uniform manner to provide a consistent accessible route for able-bodied and disabled pedestrians through the work zones.

The Contractor shall follow the latest edition Federal MUTCD Standards and Guidance for Pedestrian and Worker Safety and TTC Devices. When existing pedestrian facilities are disrupted, closed, or relocated in a construction zone, the temporary pedestrian accommodation facilities shall be detectable and shall include accessibility features consistent with the features present in the existing pedestrian facility.

Pedestrian access shall be maintained to existing businesses. The Contractor shall provide ADA compliant temporary pedestrian walk surfaces to business entrances during sidewalk reconstruction operations or other operations that would otherwise inhibit access.

The Contractor shall refer to figure 6H-28 – “Sidewalk Detour or Diversion”, and figure 6H-29 – “Crosswalk Closures and Pedestrian Detours (TA-29)” in the 2009 MUTCD for guidance on managing pedestrians in the vicinity of work zones within sidewalk areas. The Contractor shall provide as a minimum these levels of temporary pedestrian signing and protection measures for this project.

Temporarily installed or relocated crosswalks shall include temporary ADA accessible curb ramps, including detectable warning devices (truncated domes) to access sidewalks.

MEASUREMENT AND PAYMENT

Payment for all work under this Item shall be made at the contract unit price, lump sum, which shall include all work preparing, implementing, inspecting, maintaining, and removing the applicable Site-Specific Traffic Control Plan and specified traffic control devices; for furnishing all labor, tools, materials, equipment, and incidentals necessary to complete the work, including roadway flaggers, traffic cones and safety signing for traffic management, temporary pavement markings, arrow boards, reflectorized drums, temporary barrier, portable breakaway barricades Type III, temporary impact attenuators, portable changeable message signs, truck-mounted attenuators, construction fence, temporary curb ramps; and for all materials and measures required to protect pedestrians and to maintain pedestrian access routes through the project at all times: installing, adjusting, relocating, and removing aids to pedestrian accessible routes, including channelizing devices, handrails, detectable edging, temporary curb ramps, detectable warning devices, temporary pedestrian signing, and pavement markings; and any other items associated with temporary traffic control.

PAYMENT ITEMS

850.	Temporary Traffic Control	Lump Sum
------	---------------------------	----------

ITEM 874.
ITEM 874.1
ITEM 874.2

STREET SIGN
STREET SIGN REMOVED AND RESET
TRAFFIC SIGN REMOVED AND RESET

EACH
EACH
EACH

The work under these items shall conform to the relevant provisions of Section 828 of the Standard Specifications and the following:

The Contractor shall carefully remove and reset at new locations all existing signs, attachment hardware and sign support posts not included under other sign items as shown on the drawings and as directed by the Engineer.

Signs, attachment hardware and sign support posts shall be satisfactorily stored and protected until reset in the proposed work.

Signs, attachment hardware and sign support posts lost, damaged or otherwise made unsuitable for reuse while being removed, transported, stored or reset shall be replaced with new materials at no additional cost to the Owner. New attachment hardware shall be furnished and installed as necessary to replace any missing or unusable existing hardware.

Included under Item 874.2 are Warning-Regulatory and Route Marker signs, and miscellaneous directional signs.

Street sign and traffic sign removed and reset will be measured for payment as units, complete in place.

Street sign and traffic sign removed and reset will be paid for at the respective Contract unit prices per each, which prices shall include all labor, material, equipment and incidental costs required to complete the work.

If street signs are in poor condition, as determined by the Engineer, they will be replaced and paid for under Item 874.

ITEM 874.7**MISCELLANEOUS SIGN REMOVED AND STACKED****EACH**

The work under these items shall conform to the relevant provisions of Section 828 of the Standard Specifications and the following:

The work shall include the careful removal, transporting and stacking of signs, attached hardware and supports from locations shown on the plans and as directed by the Engineer.

The contractor shall accept and hold entirely responsibility for the removal, handling and stacking at a location convenient for removal by the owner. Any signs and posts damaged or lost either directly or indirectly as a result of the Contractor's operations shall be replaced by the Contractor at no additional cost to the Owner. The Contractor shall coordinate the removal of signs and posts with the Town or Owner by notifying the Town prior to and at the completion of the above work. Existing signs shall remain in place until proposed new signs are in place.

The items will be paid for at the Contract price per each, which price shall include all labor, materials, equipment and incidental costs required to complete the work.

PREVAILING WAGE RATES



**THE COMMONWEALTH OF MASSACHUSETTS
EXECUTIVE OFFICE OF LABOR AND WORKFORCE DEVELOPMENT
DEPARTMENT OF LABOR STANDARDS**

Prevailing Wage Rates

**As determined by the Director under the provisions of the
Massachusetts General Laws, Chapter 149, Sections 26 to 27H**

CHARLES D. BAKER
Governor

ROSALIN ACOSTA
Secretary

KARYN E. POLITO
Lt. Governor

WILLIAM D MCKINNEY
Director

Awarding Authority: Town of Manchester by the Sea
Contract Number: **City/Town:** MANCHESTER
Description of Work: Complete Streets upgrades at the intersections of Central St & School St, Sea St & Washington St, & Beach St & Union St
Job Location: 10 Central St, Manchester by the Sea, MA 01940

Information about Prevailing Wage Schedules for Awarding Authorities and Contractors

- This wage schedule applies only to the specific project referenced at the top of this page and uniquely identified by the “Wage Request Number” on all pages of this schedule.
- An Awarding Authority must request an updated wage schedule from the Department of Labor Standards (“DLS”) if it has not opened bids or selected a contractor within 90 days of the date of issuance of the wage schedule. For CM AT RISK projects (bid pursuant to G.L. c.149A), the earlier of: (a) the execution date of the GMP Amendment, or (b) the bid for the first construction scope of work must be within 90-days of the wage schedule issuance date.
- The wage schedule shall be incorporated in any advertisement or call for bids for the project as required by M.G.L. c. 149, § 27. The wage schedule shall be made a part of the contract awarded for the project. The wage schedule must be posted in a conspicuous place at the work site for the life of the project in accordance with M.G.L. c. 149 § 27. The wages listed on the wage schedule must be paid to employees performing construction work on the project whether they are employed by the prime contractor, a filed sub-bidder, or any sub-contractor.
- All apprentices working on the project are required to be registered with the Massachusetts Department of Labor Standards, Division of Apprentice Standards (DLS/DAS). Apprentice must keep his/her apprentice identification card on his/her person during all work hours on the project. An apprentice registered with DAS may be paid the lower apprentice wage rate at the applicable step as provided on the prevailing wage schedule. **Any apprentice not registered with DLS/DAS regardless of whether or not they are registered with any other federal, state, local, or private agency must be paid the journeyworker's rate for the trade.**
- The wage rates will remain in effect for the duration of the project, except in the case of multi-year public construction projects. For construction projects lasting longer than one year, awarding authorities must request an updated wage schedule. Awarding authorities are required to request these updates no later than two weeks before the anniversary of the date the contract was executed by the awarding authority and the general contractor. For multi-year CM AT RISK projects, awarding authority must request an annual update no later than two weeks before the anniversary date, determined as the earlier of: (a) the execution date of the GMP Amendment, or (b) the execution date of the first amendment to permit procurement of construction services. Contractors are required to obtain the wage schedules from awarding authorities, and to pay no less than these rates to covered workers. The annual update requirement is not applicable to 27F “rental of equipment” contracts.
- Every contractor or subcontractor which performs construction work on the project is required to submit weekly payroll reports and a Statement of Compliance directly to the awarding authority by mail or email and keep them on file for three years. Each weekly payroll report must contain: the employee’s name, address, occupational classification, hours worked, and wages paid. Do not submit weekly payroll reports to DLS. A sample of a payroll reporting form may be obtained at <http://www.mass.gov/dols/pw>.
- Contractors with questions about the wage rates or classifications included on the wage schedule have an affirmative obligation to inquire with DLS at (617) 626-6953.
- Employees not receiving the prevailing wage rate set forth on the wage schedule may report the violation to the Fair Labor Division of the office of the Attorney General at (617) 727-3465.
- Failure of a contractor or subcontractor to pay the prevailing wage rates listed on the wage schedule to all employees who perform construction work on the project is a violation of the law and subjects the contractor or subcontractor to civil and

Classification	Effective Date	Base Wage	Health	Pension	Supplemental Unemployment	Total Rate
Construction						
(2 AXLE) DRIVER - EQUIPMENT <i>TEAMSTERS JOINT COUNCIL NO. 10 ZONE B</i>	12/01/2018	\$33.25	\$11.91	\$12.70	\$0.00	\$57.86
	06/01/2019	\$34.25	\$11.91	\$12.70	\$0.00	\$58.86
	08/01/2019	\$34.25	\$12.41	\$12.70	\$0.00	\$59.36
	12/01/2019	\$34.25	\$12.41	\$13.72	\$0.00	\$60.38
	06/01/2020	\$35.15	\$12.41	\$13.72	\$0.00	\$61.28
	08/01/2020	\$35.15	\$12.91	\$13.72	\$0.00	\$61.78
	12/01/2020	\$35.15	\$12.91	\$14.82	\$0.00	\$62.88
	06/01/2021	\$35.95	\$12.91	\$14.82	\$0.00	\$63.68
	08/01/2021	\$35.95	\$13.41	\$14.82	\$0.00	\$64.18
	12/01/2021	\$35.95	\$13.41	\$16.01	\$0.00	\$65.37
(3 AXLE) DRIVER - EQUIPMENT <i>TEAMSTERS JOINT COUNCIL NO. 10 ZONE B</i>	12/01/2018	\$33.32	\$11.91	\$12.70	\$0.00	\$57.93
	06/01/2019	\$34.32	\$11.91	\$12.70	\$0.00	\$58.93
	08/01/2019	\$34.32	\$12.41	\$12.70	\$0.00	\$59.43
	12/01/2019	\$34.32	\$12.41	\$13.72	\$0.00	\$60.45
	06/01/2020	\$35.22	\$12.41	\$13.72	\$0.00	\$61.35
	08/01/2020	\$35.22	\$12.91	\$13.72	\$0.00	\$61.85
	12/01/2020	\$35.22	\$12.91	\$14.82	\$0.00	\$62.95
	06/01/2021	\$36.02	\$12.91	\$14.82	\$0.00	\$63.75
	08/01/2021	\$36.02	\$13.41	\$14.82	\$0.00	\$64.25
	12/01/2021	\$36.02	\$13.41	\$16.01	\$0.00	\$65.44
(4 & 5 AXLE) DRIVER - EQUIPMENT <i>TEAMSTERS JOINT COUNCIL NO. 10 ZONE B</i>	12/01/2018	\$33.44	\$11.91	\$12.70	\$0.00	\$58.05
	06/01/2019	\$34.44	\$11.91	\$12.70	\$0.00	\$59.05
	08/01/2019	\$34.44	\$12.41	\$12.70	\$0.00	\$59.55
	12/01/2019	\$34.44	\$12.41	\$13.72	\$0.00	\$60.57
	06/01/2020	\$35.34	\$12.41	\$13.72	\$0.00	\$61.47
	08/01/2020	\$35.34	\$12.91	\$13.72	\$0.00	\$61.97
	12/01/2020	\$35.34	\$12.91	\$14.82	\$0.00	\$63.07
	06/01/2021	\$36.14	\$12.91	\$14.82	\$0.00	\$63.87
	08/01/2021	\$36.14	\$13.41	\$14.82	\$0.00	\$64.37
	12/01/2021	\$36.14	\$13.41	\$16.01	\$0.00	\$65.56
ADS/SUBMERSIBLE PILOT <i>PILE DRIVER LOCAL 56 (ZONE 1)</i>	08/01/2018	\$97.80	\$9.90	\$21.15	\$0.00	\$128.85
	08/01/2019	\$102.78	\$9.90	\$21.15	\$0.00	\$133.83
For apprentice rates see "Apprentice- PILE DRIVER"						
AIR TRACK OPERATOR <i>LABORERS - ZONE 2</i>	12/01/2018	\$34.27	\$7.85	\$14.44	\$0.00	\$56.56
	06/01/2019	\$35.14	\$7.85	\$14.44	\$0.00	\$57.43
	12/01/2019	\$36.00	\$7.85	\$14.44	\$0.00	\$58.29
	06/01/2020	\$36.89	\$7.85	\$14.44	\$0.00	\$59.18
	12/01/2020	\$37.78	\$7.85	\$14.44	\$0.00	\$60.07
	06/01/2021	\$38.70	\$7.85	\$14.44	\$0.00	\$60.99
	12/01/2021	\$39.61	\$7.85	\$14.44	\$0.00	\$61.90
For apprentice rates see "Apprentice- LABORER"						

Classification	Effective Date	Base Wage	Health	Pension	Supplemental Unemployment	Total Rate
ASBESTOS REMOVER - PIPE / MECH. EQUIPT. <i>HEAT & FROST INSULATORS LOCAL 6 (BOSTON)</i>	12/01/2018	\$35.40	\$12.50	\$8.50	\$0.00	\$56.40
	06/01/2019	\$36.40	\$12.50	\$8.50	\$0.00	\$57.40
	12/01/2019	\$37.40	\$12.50	\$8.50	\$0.00	\$58.40
	06/01/2020	\$38.40	\$12.50	\$8.50	\$0.00	\$59.40
	12/01/2020	\$39.40	\$12.50	\$8.50	\$0.00	\$60.40
ASPHALT RAKER <i>LABORERS - ZONE 2</i>	12/01/2018	\$33.77	\$7.85	\$14.44	\$0.00	\$56.06
	06/01/2019	\$34.64	\$7.85	\$14.44	\$0.00	\$56.93
	12/01/2019	\$35.50	\$7.85	\$14.44	\$0.00	\$57.79
	06/01/2020	\$36.39	\$7.85	\$14.44	\$0.00	\$58.68
	12/01/2020	\$37.28	\$7.85	\$14.44	\$0.00	\$59.57
	06/01/2021	\$38.20	\$7.85	\$14.44	\$0.00	\$60.49
	12/01/2021	\$39.11	\$7.85	\$14.44	\$0.00	\$61.40
For apprentice rates see "Apprentice- LABORER"						
ASPHALT/CONCRETE/CRUSHER PLANT-ON SITE <i>OPERATING ENGINEERS LOCAL 4</i>	12/01/2018	\$47.58	\$11.50	\$15.60	\$0.00	\$74.68
	06/01/2019	\$48.68	\$11.50	\$15.60	\$0.00	\$75.78
	12/01/2019	\$49.83	\$11.50	\$15.60	\$0.00	\$76.93
	06/01/2020	\$50.93	\$11.50	\$15.60	\$0.00	\$78.03
	12/01/2020	\$52.08	\$11.50	\$15.60	\$0.00	\$79.18
	06/01/2021	\$53.18	\$11.50	\$15.60	\$0.00	\$80.28
	12/01/2021	\$54.33	\$11.50	\$15.60	\$0.00	\$81.43
For apprentice rates see "Apprentice- OPERATING ENGINEERS"						
BACKHOE/FRONT-END LOADER <i>OPERATING ENGINEERS LOCAL 4</i>	12/01/2018	\$47.58	\$11.50	\$15.60	\$0.00	\$74.68
	06/01/2019	\$48.68	\$11.50	\$15.60	\$0.00	\$75.78
	12/01/2019	\$49.83	\$11.50	\$15.60	\$0.00	\$76.93
	06/01/2020	\$50.93	\$11.50	\$15.60	\$0.00	\$78.03
	12/01/2020	\$52.08	\$11.50	\$15.60	\$0.00	\$79.18
	06/01/2021	\$53.18	\$11.50	\$15.60	\$0.00	\$80.28
	12/01/2021	\$54.33	\$11.50	\$15.60	\$0.00	\$81.43
For apprentice rates see "Apprentice- OPERATING ENGINEERS"						
BARCO-TYPE JUMPING TAMPER <i>LABORERS - ZONE 2</i>	12/01/2018	\$33.77	\$7.85	\$14.44	\$0.00	\$56.06
	06/01/2019	\$34.64	\$7.85	\$14.44	\$0.00	\$56.93
	12/01/2019	\$35.50	\$7.85	\$14.44	\$0.00	\$57.79
	06/01/2020	\$36.39	\$7.85	\$14.44	\$0.00	\$58.68
	12/01/2020	\$37.28	\$7.85	\$14.44	\$0.00	\$59.57
	06/01/2021	\$38.20	\$7.85	\$14.44	\$0.00	\$60.49
	12/01/2021	\$39.11	\$7.85	\$14.44	\$0.00	\$61.40
For apprentice rates see "Apprentice- LABORER"						
BLOCK PAVER, RAMMER / CURB SETTER <i>LABORERS - ZONE 2</i>	12/01/2018	\$34.27	\$7.85	\$14.44	\$0.00	\$56.56
	06/01/2019	\$35.14	\$7.85	\$14.44	\$0.00	\$57.43
	12/01/2019	\$36.00	\$7.85	\$14.44	\$0.00	\$58.29
	06/01/2020	\$36.89	\$7.85	\$14.44	\$0.00	\$59.18
	12/01/2020	\$37.78	\$7.85	\$14.44	\$0.00	\$60.07
	06/01/2021	\$38.70	\$7.85	\$14.44	\$0.00	\$60.99
	12/01/2021	\$39.61	\$7.85	\$14.44	\$0.00	\$61.90
For apprentice rates see "Apprentice- LABORER"						

Classification	Effective Date	Base Wage	Health	Pension	Supplemental Unemployment	Total Rate
BOILER MAKER	01/01/2019	\$44.71	\$7.07	\$17.72	\$0.00	\$69.50
<i>BOILERMAKERS LOCAL 29</i>	01/01/2020	\$46.10	\$7.07	\$17.98	\$0.00	\$71.15

Apprentice - BOILERMAKER - Local 29

Effective Date - 01/01/2019

Step	percent	Apprentice Base Wage	Health	Pension	Supplemental Unemployment	Total Rate
1	65	\$29.06	\$7.07	\$11.52	\$0.00	\$47.65
2	65	\$29.06	\$7.07	\$11.52	\$0.00	\$47.65
3	70	\$31.30	\$7.07	\$12.40	\$0.00	\$50.77
4	75	\$33.53	\$7.07	\$13.30	\$0.00	\$53.90
5	80	\$35.77	\$7.07	\$14.18	\$0.00	\$57.02
6	85	\$38.00	\$7.07	\$15.07	\$0.00	\$60.14
7	90	\$40.24	\$7.07	\$15.95	\$0.00	\$63.26
8	95	\$42.47	\$7.07	\$16.84	\$0.00	\$66.38

Effective Date - 01/01/2020

Step	percent	Apprentice Base Wage	Health	Pension	Supplemental Unemployment	Total Rate
1	65	\$29.97	\$7.07	\$11.69	\$0.00	\$48.73
2	65	\$29.97	\$7.07	\$11.69	\$0.00	\$48.73
3	70	\$32.27	\$7.07	\$12.59	\$0.00	\$51.93
4	75	\$34.58	\$7.07	\$13.49	\$0.00	\$55.14
5	80	\$36.88	\$7.07	\$14.38	\$0.00	\$58.33
6	85	\$39.19	\$7.07	\$15.29	\$0.00	\$61.55
7	90	\$41.49	\$7.07	\$16.18	\$0.00	\$64.74
8	95	\$43.80	\$7.07	\$17.09	\$0.00	\$67.96

Notes:

Apprentice to Journeyworker Ratio:1:4

BRICK/STONE/ARTIFICIAL MASONRY (INCL. MASONRY WATERPROOFING)	02/01/2019	\$53.55	\$10.75	\$20.66	\$0.00	\$84.96
<i>BRICKLAYERS LOCAL 3 (LYNN)</i>	08/01/2019	\$54.90	\$10.75	\$20.80	\$0.00	\$86.45
	02/01/2020	\$55.54	\$10.75	\$20.80	\$0.00	\$87.09
	08/01/2020	\$56.89	\$10.75	\$20.95	\$0.00	\$88.59
	02/01/2021	\$57.53	\$10.75	\$20.95	\$0.00	\$89.23
	08/01/2021	\$58.93	\$10.75	\$21.11	\$0.00	\$90.79
	02/01/2022	\$59.52	\$10.75	\$21.11	\$0.00	\$91.38

Classification

Effective Date Base Wage Health Pension Supplemental Unemployment Total Rate

Apprentice - BRICK/PLASTER/CEMENT MASON - Local 3 Lynn

Effective Date - 02/01/2019

Step	percent	Apprentice Base Wage	Health	Pension	Supplemental Unemployment	Total Rate
1	50	\$26.78	\$10.75	\$20.66	\$0.00	\$58.19
2	60	\$32.13	\$10.75	\$20.66	\$0.00	\$63.54
3	70	\$37.49	\$10.75	\$20.66	\$0.00	\$68.90
4	80	\$42.84	\$10.75	\$20.66	\$0.00	\$74.25
5	90	\$48.20	\$10.75	\$20.66	\$0.00	\$79.61

Effective Date - 08/01/2019

Step	percent	Apprentice Base Wage	Health	Pension	Supplemental Unemployment	Total Rate
1	50	\$27.45	\$10.75	\$20.80	\$0.00	\$59.00
2	60	\$32.94	\$10.75	\$20.80	\$0.00	\$64.49
3	70	\$38.43	\$10.75	\$20.80	\$0.00	\$69.98
4	80	\$43.92	\$10.75	\$20.80	\$0.00	\$75.47
5	90	\$49.41	\$10.75	\$20.80	\$0.00	\$80.96

Notes:

Apprentice to Journeyworker Ratio:1:5

BULLDOZER/GRADER/SCRAPER	12/01/2018	\$47.10	\$11.50	\$15.60	\$0.00	\$74.20
<i>OPERATING ENGINEERS LOCAL 4</i>	06/01/2019	\$48.19	\$11.50	\$15.60	\$0.00	\$75.29
	12/01/2019	\$49.33	\$11.50	\$15.60	\$0.00	\$76.43
	06/01/2020	\$50.41	\$11.50	\$15.60	\$0.00	\$77.51
	12/01/2020	\$51.55	\$11.50	\$15.60	\$0.00	\$78.65
	06/01/2021	\$52.64	\$11.50	\$15.60	\$0.00	\$79.74
	12/01/2021	\$53.78	\$11.50	\$15.60	\$0.00	\$80.88

For apprentice rates see "Apprentice- OPERATING ENGINEERS"

CAISSON & UNDERPINNING BOTTOM MAN	12/01/2018	\$39.75	\$7.85	\$15.55	\$0.00	\$63.15
<i>LABORERS - FOUNDATION AND MARINE</i>	06/01/2019	\$40.75	\$7.85	\$15.55	\$0.00	\$64.15
	12/01/2019	\$41.75	\$7.85	\$15.55	\$0.00	\$65.15
	06/01/2020	\$42.74	\$7.85	\$15.55	\$0.00	\$66.14
	12/01/2020	\$43.72	\$7.85	\$15.55	\$0.00	\$67.12
	06/01/2021	\$44.74	\$7.85	\$15.55	\$0.00	\$68.14
	12/01/2021	\$45.75	\$7.85	\$15.55	\$0.00	\$69.15

For apprentice rates see "Apprentice- LABORER"

CAISSON & UNDERPINNING LABORER	12/01/2018	\$38.60	\$7.85	\$15.55	\$0.00	\$62.00
<i>LABORERS - FOUNDATION AND MARINE</i>	06/01/2019	\$39.60	\$7.85	\$15.55	\$0.00	\$63.00
	12/01/2019	\$40.60	\$7.85	\$15.55	\$0.00	\$64.00
	06/01/2020	\$41.59	\$7.85	\$15.55	\$0.00	\$64.99
	12/01/2020	\$42.57	\$7.85	\$15.55	\$0.00	\$65.97
	06/01/2021	\$43.59	\$7.85	\$15.55	\$0.00	\$66.99
	12/01/2021	\$44.60	\$7.85	\$15.55	\$0.00	\$68.00

For apprentice rates see "Apprentice- LABORER"

Classification	Effective Date	Base Wage	Health	Pension	Supplemental Unemployment	Total Rate
CAISSON & UNDERPINNING TOP MAN <i>LABORERS - FOUNDATION AND MARINE</i>	12/01/2018	\$38.60	\$7.85	\$15.55	\$0.00	\$62.00
	06/01/2019	\$39.60	\$7.85	\$15.55	\$0.00	\$63.00
	12/01/2019	\$40.60	\$7.85	\$15.55	\$0.00	\$64.00
	06/01/2020	\$41.59	\$7.85	\$15.55	\$0.00	\$64.99
	12/01/2020	\$42.57	\$7.85	\$15.55	\$0.00	\$65.97
	06/01/2021	\$43.59	\$7.85	\$15.55	\$0.00	\$66.99
	12/01/2021	\$44.60	\$7.85	\$15.55	\$0.00	\$68.00
For apprentice rates see "Apprentice- LABORER"						
CARBIDE CORE DRILL OPERATOR <i>LABORERS - ZONE 2</i>	12/01/2018	\$33.77	\$7.85	\$14.44	\$0.00	\$56.06
	06/01/2019	\$34.64	\$7.85	\$14.44	\$0.00	\$56.93
	12/01/2019	\$35.50	\$7.85	\$14.44	\$0.00	\$57.79
	06/01/2020	\$36.39	\$7.85	\$14.44	\$0.00	\$58.68
	12/01/2020	\$37.28	\$7.85	\$14.44	\$0.00	\$59.57
	06/01/2021	\$38.20	\$7.85	\$14.44	\$0.00	\$60.49
	12/01/2021	\$39.11	\$7.85	\$14.44	\$0.00	\$61.40
For apprentice rates see "Apprentice- LABORER"						
CARPENTER <i>CARPENTERS -ZONE 2 (Eastern Massachusetts)</i>	03/01/2019	\$42.35	\$9.90	\$17.50	\$0.00	\$69.75

Apprentice - CARPENTER - Zone 2 Eastern MA

Effective Date - 03/01/2019

Step	percent	Apprentice Base Wage	Health	Pension	Supplemental Unemployment	Total Rate
1	50	\$21.18	\$9.90	\$1.73	\$0.00	\$32.81
2	60	\$25.41	\$9.90	\$1.73	\$0.00	\$37.04
3	70	\$29.65	\$9.90	\$12.31	\$0.00	\$51.86
4	75	\$31.76	\$9.90	\$12.31	\$0.00	\$53.97
5	80	\$33.88	\$9.90	\$14.04	\$0.00	\$57.82
6	80	\$33.88	\$9.90	\$14.04	\$0.00	\$57.82
7	90	\$38.12	\$9.90	\$15.77	\$0.00	\$63.79
8	90	\$38.12	\$9.90	\$15.77	\$0.00	\$63.79

Notes:

% Indentured After 10/1/17; 45/45/55/55/70/70/80/80
Step 1&2 \$30.69/ 3&4 \$36.59/ 5&6 \$53.59/ 7&8 \$59.55

Apprentice to Journeyworker Ratio:1:5

CARPENTER WOOD FRAME <i>CARPENTERS -ZONE 2 (Wood Frame)</i>	04/01/2019	\$27.52	\$7.07	\$7.86	\$0.00	\$42.45
	10/01/2019	\$27.95	\$7.07	\$7.86	\$0.00	\$42.88

All Aspects of New Wood Frame Work

Classification

Effective Date Base Wage Health Pension Supplemental Unemployment Total Rate

Apprentice - CARPENTER (Wood Frame) - Zone 2

Effective Date - 04/01/2019

Step	percent	Apprentice Base Wage	Health	Pension	Supplemental Unemployment	Total Rate
1	60	\$16.51	\$7.07	\$0.00	\$0.00	\$23.58
2	60	\$16.51	\$7.07	\$0.00	\$0.00	\$23.58
3	65	\$17.89	\$7.07	\$7.86	\$0.00	\$32.82
4	70	\$19.26	\$7.07	\$7.86	\$0.00	\$34.19
5	75	\$20.64	\$7.07	\$7.86	\$0.00	\$35.57
6	80	\$22.02	\$7.07	\$7.86	\$0.00	\$36.95
7	85	\$23.39	\$7.07	\$7.86	\$0.00	\$38.32
8	90	\$24.77	\$7.07	\$7.86	\$0.00	\$39.70

Effective Date - 10/01/2019

Step	percent	Apprentice Base Wage	Health	Pension	Supplemental Unemployment	Total Rate
1	60	\$16.77	\$7.07	\$0.00	\$0.00	\$23.84
2	60	\$16.77	\$7.07	\$0.00	\$0.00	\$23.84
3	65	\$18.17	\$7.07	\$7.86	\$0.00	\$33.10
4	70	\$19.57	\$7.07	\$7.86	\$0.00	\$34.50
5	75	\$20.96	\$7.07	\$7.86	\$0.00	\$35.89
6	80	\$22.36	\$7.07	\$7.86	\$0.00	\$37.29
7	85	\$23.76	\$7.07	\$7.86	\$0.00	\$38.69
8	90	\$25.16	\$7.07	\$7.86	\$0.00	\$40.09

Notes:
 % Indentured After 10/1/17; 45/45/55/55/70/70/80/80
 Step 1&2 \$19.45/ 3&4 \$26.96/ 5&6 \$34.19/ 7&8 \$36.95

Apprentice to Journeyworker Ratio:1:5

CEMENT MASONRY/PLASTERING	01/01/2019	\$47.50	\$12.50	\$22.41	\$0.30	\$82.71
BRICKLAYERS LOCAL 3 (LYNN)	07/01/2019	\$48.24	\$12.50	\$22.41	\$0.30	\$83.45
	01/01/2020	\$49.64	\$12.50	\$22.41	\$0.30	\$84.85

Classification

Effective Date Base Wage Health Pension Supplemental Unemployment Total Rate

Apprentice - CEMENT MASONRY/PLASTERING - Eastern Mass (Lynn)

Effective Date - 01/01/2019

Step	percent	Apprentice Base Wage	Health	Pension	Supplemental Unemployment	Total Rate
1	50	\$23.75	\$12.50	\$15.41	\$0.00	\$51.66
2	60	\$28.50	\$12.50	\$17.41	\$0.30	\$58.71
3	65	\$30.88	\$12.50	\$18.41	\$0.30	\$62.09
4	70	\$33.25	\$12.50	\$19.41	\$0.30	\$65.46
5	75	\$35.63	\$12.50	\$20.41	\$0.30	\$68.84
6	80	\$38.00	\$12.50	\$21.41	\$0.30	\$72.21
7	90	\$42.75	\$12.50	\$22.41	\$0.30	\$77.96

Effective Date - 07/01/2019

Step	percent	Apprentice Base Wage	Health	Pension	Supplemental Unemployment	Total Rate
1	50	\$24.12	\$12.50	\$15.41	\$0.00	\$52.03
2	60	\$28.94	\$12.50	\$17.41	\$0.30	\$59.15
3	65	\$31.36	\$12.50	\$18.41	\$0.30	\$62.57
4	70	\$33.77	\$12.50	\$19.41	\$0.30	\$65.98
5	75	\$36.18	\$12.50	\$20.41	\$0.30	\$69.39
6	80	\$38.59	\$12.50	\$21.41	\$0.30	\$72.80
7	90	\$43.42	\$12.50	\$22.41	\$0.30	\$78.63

Notes:

Steps 3,4 are 500 hrs. All other steps are 1,000 hrs.

Apprentice to Journeyworker Ratio:1:3

CHAIN SAW OPERATOR	12/01/2018	\$33.77	\$7.85	\$14.44	\$0.00	\$56.06
LABORERS - ZONE 2	06/01/2019	\$34.64	\$7.85	\$14.44	\$0.00	\$56.93
	12/01/2019	\$35.50	\$7.85	\$14.44	\$0.00	\$57.79
	06/01/2020	\$36.39	\$7.85	\$14.44	\$0.00	\$58.68
	12/01/2020	\$37.28	\$7.85	\$14.44	\$0.00	\$59.57
	06/01/2021	\$38.20	\$7.85	\$14.44	\$0.00	\$60.49
	12/01/2021	\$39.11	\$7.85	\$14.44	\$0.00	\$61.40

For apprentice rates see "Apprentice- LABORER"

CLAM SHELLS/SLURRY BUCKETS/HEADING MACHINES	12/01/2018	\$48.58	\$11.50	\$15.60	\$0.00	\$75.68
OPERATING ENGINEERS LOCAL 4	06/01/2019	\$49.68	\$11.50	\$15.60	\$0.00	\$76.78
	12/01/2019	\$50.83	\$11.50	\$15.60	\$0.00	\$77.93
	06/01/2020	\$51.93	\$11.50	\$15.60	\$0.00	\$79.03
	12/01/2020	\$53.08	\$11.50	\$15.60	\$0.00	\$80.18
	06/01/2021	\$54.18	\$11.50	\$15.60	\$0.00	\$81.28
	12/01/2021	\$55.33	\$11.50	\$15.60	\$0.00	\$82.43

For apprentice rates see "Apprentice- OPERATING ENGINEERS"

Classification	Effective Date	Base Wage	Health	Pension	Supplemental Unemployment	Total Rate
COMPRESSOR OPERATOR <i>OPERATING ENGINEERS LOCAL 4</i>	12/01/2018	\$32.03	\$11.50	\$15.60	\$0.00	\$59.13
	06/01/2019	\$32.78	\$11.50	\$15.60	\$0.00	\$59.88
	12/01/2019	\$33.57	\$11.50	\$15.60	\$0.00	\$60.67
	06/01/2020	\$34.32	\$11.50	\$15.60	\$0.00	\$61.42
	12/01/2020	\$35.10	\$11.50	\$15.60	\$0.00	\$62.20
	06/01/2021	\$35.85	\$11.50	\$15.60	\$0.00	\$62.95
	12/01/2021	\$36.64	\$11.50	\$15.60	\$0.00	\$63.74

For apprentice rates see "Apprentice- OPERATING ENGINEERS"

DELEADER (BRIDGE) <i>PAINTERS LOCAL 35 - ZONE 2</i>	01/01/2019	\$50.36	\$8.15	\$20.85	\$0.00	\$79.36
	07/01/2019	\$51.46	\$8.15	\$20.85	\$0.00	\$80.46
	01/01/2020	\$52.56	\$8.15	\$20.85	\$0.00	\$81.56
	07/01/2020	\$53.66	\$8.15	\$20.85	\$0.00	\$82.66
	01/01/2021	\$54.76	\$8.15	\$20.85	\$0.00	\$83.76

Apprentice - PAINTER Local 35 - BRIDGES/TANKS

Effective Date - 01/01/2019

Step	percent	Apprentice Base Wage	Health	Pension	Supplemental Unemployment	Total Rate
1	50	\$25.18	\$8.15	\$0.00	\$0.00	\$33.33
2	55	\$27.70	\$8.15	\$5.64	\$0.00	\$41.49
3	60	\$30.22	\$8.15	\$6.15	\$0.00	\$44.52
4	65	\$32.73	\$8.15	\$6.66	\$0.00	\$47.54
5	70	\$35.25	\$8.15	\$17.78	\$0.00	\$61.18
6	75	\$37.77	\$8.15	\$18.29	\$0.00	\$64.21
7	80	\$40.29	\$8.15	\$18.80	\$0.00	\$67.24
8	90	\$45.32	\$8.15	\$19.83	\$0.00	\$73.30

Effective Date - 07/01/2019

Step	percent	Apprentice Base Wage	Health	Pension	Supplemental Unemployment	Total Rate
1	50	\$25.73	\$8.15	\$0.00	\$0.00	\$33.88
2	55	\$28.30	\$8.15	\$5.64	\$0.00	\$42.09
3	60	\$30.88	\$8.15	\$6.15	\$0.00	\$45.18
4	65	\$33.45	\$8.15	\$6.66	\$0.00	\$48.26
5	70	\$36.02	\$8.15	\$17.78	\$0.00	\$61.95
6	75	\$38.60	\$8.15	\$18.29	\$0.00	\$65.04
7	80	\$41.17	\$8.15	\$18.80	\$0.00	\$68.12
8	90	\$46.31	\$8.15	\$19.83	\$0.00	\$74.29

Notes:

Steps are 750 hrs.

Apprentice to Journeyworker Ratio:1:1

DEMO: ADZEMAN <i>LABORERS - ZONE 2</i>	12/01/2018	\$38.80	\$7.85	\$15.35	\$0.00	\$62.00
	06/01/2019	\$39.80	\$7.85	\$15.35	\$0.00	\$63.00
	12/01/2019	\$40.80	\$7.85	\$15.35	\$0.00	\$64.00

For apprentice rates see "Apprentice- LABORER"

Classification	Effective Date	Base Wage	Health	Pension	Supplemental Unemployment	Total Rate
DEMO: BACKHOE/LOADER/HAMMER OPERATOR <i>LABORERS - ZONE 2</i>	12/01/2018	\$39.80	\$7.85	\$15.35	\$0.00	\$63.00
	06/01/2019	\$40.80	\$7.85	\$15.35	\$0.00	\$64.00
	12/01/2019	\$41.80	\$7.85	\$15.35	\$0.00	\$65.00
For apprentice rates see "Apprentice- LABORER"						
DEMO: BURNERS <i>LABORERS - ZONE 2</i>	12/01/2018	\$39.55	\$7.85	\$15.35	\$0.00	\$62.75
	06/01/2019	\$40.55	\$7.85	\$15.35	\$0.00	\$63.75
	12/01/2019	\$41.55	\$7.85	\$15.35	\$0.00	\$64.75
For apprentice rates see "Apprentice- LABORER"						
DEMO: CONCRETE CUTTER/SAWYER <i>LABORERS - ZONE 2</i>	12/01/2018	\$39.80	\$7.85	\$15.35	\$0.00	\$63.00
	06/01/2019	\$40.80	\$7.85	\$15.35	\$0.00	\$64.00
	12/01/2019	\$41.80	\$7.85	\$15.35	\$0.00	\$65.00
For apprentice rates see "Apprentice- LABORER"						
DEMO: JACKHAMMER OPERATOR <i>LABORERS - ZONE 2</i>	12/01/2018	\$39.55	\$7.85	\$15.35	\$0.00	\$62.75
	06/01/2019	\$40.55	\$7.85	\$15.35	\$0.00	\$63.75
	12/01/2019	\$41.55	\$7.85	\$15.35	\$0.00	\$64.75
For apprentice rates see "Apprentice- LABORER"						
DEMO: WRECKING LABORER <i>LABORERS - ZONE 2</i>	12/01/2018	\$38.80	\$7.85	\$15.35	\$0.00	\$62.00
	06/01/2019	\$39.80	\$7.85	\$15.35	\$0.00	\$63.00
	12/01/2019	\$40.80	\$7.85	\$15.35	\$0.00	\$64.00
For apprentice rates see "Apprentice- LABORER"						
DIRECTIONAL DRILL MACHINE OPERATOR <i>OPERATING ENGINEERS LOCAL 4</i>	12/01/2018	\$47.10	\$11.50	\$15.60	\$0.00	\$74.20
	06/01/2019	\$48.19	\$11.50	\$15.60	\$0.00	\$75.29
	12/01/2019	\$49.33	\$11.50	\$15.60	\$0.00	\$76.43
	06/01/2020	\$50.41	\$11.50	\$15.60	\$0.00	\$77.51
	12/01/2020	\$51.55	\$11.50	\$15.60	\$0.00	\$78.65
	06/01/2021	\$52.64	\$11.50	\$15.60	\$0.00	\$79.74
	12/01/2021	\$53.78	\$11.50	\$15.60	\$0.00	\$80.88
For apprentice rates see "Apprentice- OPERATING ENGINEERS"						
DIVER <i>PILE DRIVER LOCAL 56 (ZONE 1)</i>	08/01/2018	\$65.20	\$9.90	\$21.15	\$0.00	\$96.25
	08/01/2019	\$68.52	\$9.90	\$21.15	\$0.00	\$99.57
For apprentice rates see "Apprentice- PILE DRIVER"						
DIVER TENDER <i>PILE DRIVER LOCAL 56 (ZONE 1)</i>	08/01/2018	\$46.57	\$9.90	\$21.15	\$0.00	\$77.62
	08/01/2019	\$48.94	\$9.90	\$21.15	\$0.00	\$79.99
For apprentice rates see "Apprentice- PILE DRIVER"						
DIVER TENDER (EFFLUENT) <i>PILE DRIVER LOCAL 56 (ZONE 1)</i>	08/01/2018	\$69.86	\$9.90	\$21.15	\$0.00	\$100.91
	08/01/2019	\$73.41	\$9.90	\$21.15	\$0.00	\$104.46
For apprentice rates see "Apprentice- PILE DRIVER"						
DIVER/SLURRY (EFFLUENT) <i>PILE DRIVER LOCAL 56 (ZONE 1)</i>	08/01/2018	\$97.80	\$9.90	\$21.15	\$0.00	\$128.85
	08/01/2019	\$102.78	\$9.90	\$21.15	\$0.00	\$133.83
For apprentice rates see "Apprentice- PILE DRIVER"						
DRAWBRIDGE OPERATOR (Construction) <i>ELECTRICIANS LOCAL 103</i>	03/01/2019	\$51.10	\$13.00	\$18.88	\$0.00	\$82.98
For apprentice rates see "Apprentice- ELECTRICIAN"						
ELECTRICIAN <i>ELECTRICIANS LOCAL 103</i>	03/01/2019	\$51.10	\$13.00	\$18.88	\$0.00	\$82.98

Apprentice - ELECTRICIAN - Local 103

Effective Date - 03/01/2019

Step	percent	Apprentice Base Wage	Health	Pension	Supplemental Unemployment	Total Rate
1	40	\$20.44	\$13.00	\$0.61	\$0.00	\$34.05
2	40	\$20.44	\$13.00	\$0.61	\$0.00	\$34.05
3	45	\$23.00	\$13.00	\$14.34	\$0.00	\$50.34
4	45	\$23.00	\$13.00	\$14.34	\$0.00	\$50.34
5	50	\$25.55	\$13.00	\$14.76	\$0.00	\$53.31
6	55	\$28.11	\$13.00	\$15.17	\$0.00	\$56.28
7	60	\$30.66	\$13.00	\$15.58	\$0.00	\$59.24
8	65	\$33.22	\$13.00	\$16.00	\$0.00	\$62.22
9	70	\$35.77	\$13.00	\$16.40	\$0.00	\$65.17
10	75	\$38.33	\$13.00	\$16.82	\$0.00	\$68.15

Notes:
App Prior 1/1/03; 30/35/40/45/50/55/65/70/75/80

Apprentice to Journeyworker Ratio:2:3***

ELEVATOR CONSTRUCTOR	01/01/2019	\$59.47	\$15.58	\$17.51	\$0.00	\$92.56
ELEVATOR CONSTRUCTORS LOCAL 4	01/01/2020	\$61.42	\$15.73	\$18.41	\$0.00	\$95.56
	01/01/2021	\$63.47	\$15.88	\$19.31	\$0.00	\$98.66
	01/01/2022	\$65.62	\$16.03	\$20.21	\$0.00	\$101.86

Apprentice - ELEVATOR CONSTRUCTOR - Local 4

Effective Date - 01/01/2019

Step	percent	Apprentice Base Wage	Health	Pension	Supplemental Unemployment	Total Rate
1	50	\$29.74	\$15.58	\$0.00	\$0.00	\$45.32
2	55	\$32.71	\$15.58	\$17.51	\$0.00	\$65.80
3	65	\$38.66	\$15.58	\$17.51	\$0.00	\$71.75
4	70	\$41.63	\$15.58	\$17.51	\$0.00	\$74.72
5	80	\$47.58	\$15.58	\$17.51	\$0.00	\$80.67

Effective Date - 01/01/2020

Step	percent	Apprentice Base Wage	Health	Pension	Supplemental Unemployment	Total Rate
1	50	\$30.71	\$15.73	\$0.00	\$0.00	\$46.44
2	55	\$33.78	\$15.73	\$18.41	\$0.00	\$67.92
3	65	\$39.92	\$15.73	\$18.41	\$0.00	\$74.06
4	70	\$42.99	\$15.73	\$18.41	\$0.00	\$77.13
5	80	\$49.14	\$15.73	\$18.41	\$0.00	\$83.28

Notes:
Steps 1-2 are 6 mos.; Steps 3-5 are 1 year

Apprentice to Journeyworker Ratio:1:1

Classification	Effective Date	Base Wage	Health	Pension	Supplemental Unemployment	Total Rate
ELEVATOR CONSTRUCTOR HELPER <i>ELEVATOR CONSTRUCTORS LOCAL 4</i>	01/01/2019	\$41.63	\$15.58	\$17.51	\$0.00	\$74.72
	01/01/2020	\$42.99	\$15.73	\$18.41	\$0.00	\$77.13
	01/01/2021	\$44.43	\$15.88	\$19.31	\$0.00	\$79.62
	01/01/2022	\$45.93	\$16.03	\$20.21	\$0.00	\$82.17
For apprentice rates see "Apprentice - ELEVATOR CONSTRUCTOR"						
FENCE & GUARD RAIL ERECTOR <i>LABORERS - ZONE 2</i>	12/01/2018	\$33.77	\$7.85	\$14.44	\$0.00	\$56.06
	06/01/2019	\$34.64	\$7.85	\$14.44	\$0.00	\$56.93
	12/01/2019	\$35.50	\$7.85	\$14.44	\$0.00	\$57.79
	06/01/2020	\$36.39	\$7.85	\$14.44	\$0.00	\$58.68
	12/01/2020	\$37.28	\$7.85	\$14.44	\$0.00	\$59.57
	06/01/2021	\$38.20	\$7.85	\$14.44	\$0.00	\$60.49
	12/01/2021	\$39.11	\$7.85	\$14.44	\$0.00	\$61.40
For apprentice rates see "Apprentice- LABORER"						
FIELD ENG.INST.PERSON-BLDG,SITE,HVY/HWY <i>OPERATING ENGINEERS LOCAL 4</i>	11/01/2018	\$43.19	\$11.00	\$15.50	\$0.00	\$69.69
	05/01/2019	\$44.33	\$11.00	\$15.50	\$0.00	\$70.83
	11/01/2019	\$45.33	\$11.00	\$15.50	\$0.00	\$71.83
	05/01/2020	\$46.48	\$11.00	\$15.50	\$0.00	\$72.98
	11/01/2020	\$47.48	\$11.00	\$15.50	\$0.00	\$73.98
	05/01/2021	\$48.68	\$11.00	\$15.50	\$0.00	\$75.18
	11/01/2021	\$49.63	\$11.00	\$15.50	\$0.00	\$76.13
	05/01/2022	\$50.78	\$11.00	\$15.50	\$0.00	\$77.28
For apprentice rates see "Apprentice- OPERATING ENGINEERS"						
FIELD ENG.PARTY CHIEF-BLDG,SITE,HVY/HWY <i>OPERATING ENGINEERS LOCAL 4</i>	11/01/2018	\$44.67	\$11.00	\$15.50	\$0.00	\$71.17
	05/01/2019	\$45.82	\$11.00	\$15.50	\$0.00	\$72.32
	11/01/2019	\$46.83	\$11.00	\$15.50	\$0.00	\$73.33
	05/01/2020	\$47.98	\$11.00	\$15.50	\$0.00	\$74.48
	11/01/2020	\$48.99	\$11.00	\$15.50	\$0.00	\$75.49
	05/01/2021	\$50.15	\$11.00	\$15.50	\$0.00	\$76.65
	11/01/2021	\$51.16	\$11.00	\$15.50	\$0.00	\$77.66
	05/01/2022	\$52.32	\$11.00	\$15.50	\$0.00	\$78.82
For apprentice rates see "Apprentice- OPERATING ENGINEERS"						
FIELD ENG.ROD PERSON-BLDG,SITE,HVY/HWY <i>OPERATING ENGINEERS LOCAL 4</i>	11/01/2018	\$22.45	\$11.00	\$15.50	\$0.00	\$48.95
	05/01/2019	\$23.13	\$11.00	\$15.50	\$0.00	\$49.63
	11/01/2019	\$23.72	\$11.00	\$15.50	\$0.00	\$50.22
	05/01/2020	\$24.39	\$11.00	\$15.50	\$0.00	\$50.89
	11/01/2020	\$24.98	\$11.00	\$15.50	\$0.00	\$51.48
	05/01/2021	\$25.66	\$11.00	\$15.50	\$0.00	\$52.16
	11/01/2021	\$26.26	\$11.00	\$15.50	\$0.00	\$52.76
	05/01/2022	\$26.93	\$11.00	\$15.50	\$0.00	\$53.43
For apprentice rates see "Apprentice- OPERATING ENGINEERS"						
FIRE ALARM INSTALLER <i>ELECTRICIANS LOCAL 103</i>	03/01/2019	\$51.10	\$13.00	\$18.88	\$0.00	\$82.98
For apprentice rates see "Apprentice- ELECTRICIAN"						
FIRE ALARM REPAIR / MAINTENANCE / COMMISSIONING <i>ELECTRICIANS LOCAL 103</i>	03/01/2019	\$38.33	\$13.00	\$16.82	\$0.00	\$68.15
For apprentice rates see "Apprentice- TELECOMMUNICATIONS TECHNICIAN"						

Classification	Effective Date	Base Wage	Health	Pension	Supplemental Unemployment	Total Rate
FIREMAN (ASST. ENGINEER) <i>OPERATING ENGINEERS LOCAL 4</i>	12/01/2018	\$39.13	\$11.50	\$15.60	\$0.00	\$66.23
	06/01/2019	\$40.04	\$11.50	\$15.60	\$0.00	\$67.14
	12/01/2019	\$40.99	\$11.50	\$15.60	\$0.00	\$68.09
	06/01/2020	\$41.90	\$11.50	\$15.60	\$0.00	\$69.00
	12/01/2020	\$42.85	\$11.50	\$15.60	\$0.00	\$69.95
	06/01/2021	\$43.76	\$11.50	\$15.60	\$0.00	\$70.86
	12/01/2021	\$44.71	\$11.50	\$15.60	\$0.00	\$71.81
For apprentice rates see "Apprentice- OPERATING ENGINEERS"						
FLAGGER & SIGNALER <i>LABORERS - ZONE 2</i>	12/01/2018	\$22.50	\$7.85	\$14.44	\$0.00	\$44.79
	06/01/2019	\$22.50	\$7.85	\$14.44	\$0.00	\$44.79
	12/01/2019	\$23.50	\$7.85	\$14.44	\$0.00	\$45.79
	06/01/2020	\$23.50	\$7.85	\$14.44	\$0.00	\$45.79
	12/01/2020	\$24.50	\$7.85	\$14.44	\$0.00	\$46.79
	06/01/2021	\$24.50	\$7.85	\$14.44	\$0.00	\$46.79
	12/01/2021	\$24.50	\$7.85	\$14.44	\$0.00	\$46.79
For apprentice rates see "Apprentice- LABORER"						
FLOORCOVERER <i>FLOORCOVERERS LOCAL 2168 ZONE 1</i>	03/01/2016	\$42.13	\$9.80	\$17.62	\$0.00	\$69.55

Apprentice - FLOORCOVERER - Local 2168 Zone 1

Effective Date - 03/01/2016

Step	percent	Apprentice Base Wage	Health	Pension	Supplemental Unemployment	Total Rate
1	50	\$21.07	\$9.80	\$1.79	\$0.00	\$32.66
2	55	\$23.17	\$9.80	\$1.79	\$0.00	\$34.76
3	60	\$25.28	\$9.80	\$12.25	\$0.00	\$47.33
4	65	\$27.38	\$9.80	\$12.25	\$0.00	\$49.43
5	70	\$29.49	\$9.80	\$14.04	\$0.00	\$53.33
6	75	\$31.60	\$9.80	\$14.04	\$0.00	\$55.44
7	80	\$33.70	\$9.80	\$15.83	\$0.00	\$59.33
8	85	\$35.81	\$9.80	\$15.83	\$0.00	\$61.44

Notes: Steps are 750 hrs.
 % After 09/1/17; 45/45/55/55/70/70/80/80 (1500hr Steps)
 Step 1&2 \$30.55/ 3&4 \$36.49/ 5&6 \$53.33/ 7&8 \$59.33

Apprentice to Journeyworker Ratio:1:1

FORK LIFT/CHERRY PICKER <i>OPERATING ENGINEERS LOCAL 4</i>	12/01/2018	\$47.58	\$11.50	\$15.60	\$0.00	\$74.68
	06/01/2019	\$48.68	\$11.50	\$15.60	\$0.00	\$75.78
	12/01/2019	\$49.83	\$11.50	\$15.60	\$0.00	\$76.93
	06/01/2020	\$50.93	\$11.50	\$15.60	\$0.00	\$78.03
	12/01/2020	\$52.08	\$11.50	\$15.60	\$0.00	\$79.18
	06/01/2021	\$53.18	\$11.50	\$15.60	\$0.00	\$80.28
	12/01/2021	\$54.33	\$11.50	\$15.60	\$0.00	\$81.43
For apprentice rates see "Apprentice- OPERATING ENGINEERS"						

Classification	Effective Date	Base Wage	Health	Pension	Supplemental Unemployment	Total Rate
GENERATOR/LIGHTING PLANT/HEATERS <i>OPERATING ENGINEERS LOCAL 4</i>	12/01/2018	\$32.03	\$11.50	\$15.60	\$0.00	\$59.13
	06/01/2019	\$32.78	\$11.50	\$15.60	\$0.00	\$59.88
	12/01/2019	\$33.57	\$11.50	\$15.60	\$0.00	\$60.67
	06/01/2020	\$34.32	\$11.50	\$15.60	\$0.00	\$61.42
	12/01/2020	\$35.10	\$11.50	\$15.60	\$0.00	\$62.20
	06/01/2021	\$35.85	\$11.50	\$15.60	\$0.00	\$62.95
	12/01/2021	\$36.64	\$11.50	\$15.60	\$0.00	\$63.74

For apprentice rates see "Apprentice- OPERATING ENGINEERS"

GLAZIER (GLASS PLANK/AIR BARRIER/INTERIOR SYSTEMS) <i>GLAZIERS LOCAL 35 (ZONE 2)</i>	01/01/2019	\$39.86	\$8.15	\$20.85	\$0.00	\$68.86
	07/01/2019	\$40.96	\$8.15	\$20.85	\$0.00	\$69.96
	01/01/2020	\$42.06	\$8.15	\$20.85	\$0.00	\$71.06
	07/01/2020	\$43.16	\$8.15	\$20.85	\$0.00	\$72.16
	01/01/2021	\$44.26	\$8.15	\$20.85	\$0.00	\$73.26

Apprentice - GLAZIER - Local 35 Zone 2

Effective Date - 01/01/2019

Step	percent	Apprentice Base Wage	Health	Pension	Supplemental Unemployment	Total Rate
1	50	\$19.93	\$8.15	\$0.00	\$0.00	\$28.08
2	55	\$21.92	\$8.15	\$5.64	\$0.00	\$35.71
3	60	\$23.92	\$8.15	\$6.15	\$0.00	\$38.22
4	65	\$25.91	\$8.15	\$6.66	\$0.00	\$40.72
5	70	\$27.90	\$8.15	\$17.78	\$0.00	\$53.83
6	75	\$29.90	\$8.15	\$18.29	\$0.00	\$56.34
7	80	\$31.89	\$8.15	\$18.80	\$0.00	\$58.84
8	90	\$35.87	\$8.15	\$19.83	\$0.00	\$63.85

Effective Date - 07/01/2019

Step	percent	Apprentice Base Wage	Health	Pension	Supplemental Unemployment	Total Rate
1	50	\$20.48	\$8.15	\$0.00	\$0.00	\$28.63
2	55	\$22.53	\$8.15	\$5.64	\$0.00	\$36.32
3	60	\$24.58	\$8.15	\$6.15	\$0.00	\$38.88
4	65	\$26.62	\$8.15	\$6.66	\$0.00	\$41.43
5	70	\$28.67	\$8.15	\$17.78	\$0.00	\$54.60
6	75	\$30.72	\$8.15	\$18.29	\$0.00	\$57.16
7	80	\$32.77	\$8.15	\$18.80	\$0.00	\$59.72
8	90	\$36.86	\$8.15	\$19.83	\$0.00	\$64.84

Notes:

Steps are 750 hrs.

Apprentice to Journeyworker Ratio:1:1

Classification	Effective Date	Base Wage	Health	Pension	Supplemental Unemployment	Total Rate
HOISTING ENGINEER/CRANES/GRADALLS <i>OPERATING ENGINEERS LOCAL 4</i>	12/01/2018	\$47.58	\$11.50	\$15.60	\$0.00	\$74.68
	06/01/2019	\$48.68	\$11.50	\$15.60	\$0.00	\$75.78
	12/01/2019	\$49.83	\$11.50	\$15.60	\$0.00	\$76.93
	06/01/2020	\$50.93	\$11.50	\$15.60	\$0.00	\$78.03
	12/01/2020	\$52.08	\$11.50	\$15.60	\$0.00	\$79.18
	06/01/2021	\$53.18	\$11.50	\$15.60	\$0.00	\$80.28
	12/01/2021	\$54.33	\$11.50	\$15.60	\$0.00	\$81.43

Apprentice - OPERATING ENGINEERS - Local 4

Effective Date - 12/01/2018

Step	percent	Apprentice Base Wage	Health	Pension	Supplemental Unemployment	Total Rate
1	55	\$26.17	\$11.50	\$0.00	\$0.00	\$37.67
2	60	\$28.55	\$11.50	\$15.60	\$0.00	\$55.65
3	65	\$30.93	\$11.50	\$15.60	\$0.00	\$58.03
4	70	\$33.31	\$11.50	\$15.60	\$0.00	\$60.41
5	75	\$35.69	\$11.50	\$15.60	\$0.00	\$62.79
6	80	\$38.06	\$11.50	\$15.60	\$0.00	\$65.16
7	85	\$40.44	\$11.50	\$15.60	\$0.00	\$67.54
8	90	\$42.82	\$11.50	\$15.60	\$0.00	\$69.92

Effective Date - 06/01/2019

Step	percent	Apprentice Base Wage	Health	Pension	Supplemental Unemployment	Total Rate
1	55	\$26.77	\$11.50	\$0.00	\$0.00	\$38.27
2	60	\$29.21	\$11.50	\$15.60	\$0.00	\$56.31
3	65	\$31.64	\$11.50	\$15.60	\$0.00	\$58.74
4	70	\$34.08	\$11.50	\$15.60	\$0.00	\$61.18
5	75	\$36.51	\$11.50	\$15.60	\$0.00	\$63.61
6	80	\$38.94	\$11.50	\$15.60	\$0.00	\$66.04
7	85	\$41.38	\$11.50	\$15.60	\$0.00	\$68.48
8	90	\$43.81	\$11.50	\$15.60	\$0.00	\$70.91

Notes:

Apprentice to Journeyworker Ratio:1:6

HVAC (DUCTWORK) <i>SHEETMETAL WORKERS LOCAL 17 - A</i>	02/01/2019	\$46.50	\$13.20	\$24.12	\$2.52	\$86.34
	08/01/2019	\$48.10	\$13.20	\$24.12	\$2.56	\$87.98
	02/01/2020	\$49.75	\$13.20	\$24.12	\$2.61	\$89.68
	08/01/2020	\$51.35	\$13.20	\$24.12	\$2.66	\$91.33
	02/01/2021	\$53.00	\$13.20	\$24.12	\$2.71	\$93.03
	08/01/2021	\$54.75	\$13.20	\$24.12	\$2.76	\$94.83
	02/01/2022	\$56.50	\$13.20	\$24.12	\$2.81	\$96.63

For apprentice rates see "Apprentice- SHEET METAL WORKER"

HVAC (ELECTRICAL CONTROLS) <i>ELECTRICIANS LOCAL 103</i>	03/01/2019	\$51.10	\$13.00	\$18.88	\$0.00	\$82.98
---	------------	---------	---------	---------	--------	---------

For apprentice rates see "Apprentice- ELECTRICIAN"

Classification	Effective Date	Base Wage	Health	Pension	Supplemental Unemployment	Total Rate
HVAC (TESTING AND BALANCING - AIR) <i>SHEETMETAL WORKERS LOCAL 17 - A</i>	02/01/2019	\$46.50	\$13.20	\$24.12	\$2.52	\$86.34
	08/01/2019	\$48.10	\$13.20	\$24.12	\$2.56	\$87.98
	02/01/2020	\$49.75	\$13.20	\$24.12	\$2.61	\$89.68
	08/01/2020	\$51.35	\$13.20	\$24.12	\$2.66	\$91.33
	02/01/2021	\$53.00	\$13.20	\$24.12	\$2.71	\$93.03
	08/01/2021	\$54.75	\$13.20	\$24.12	\$2.76	\$94.83
	02/01/2022	\$56.50	\$13.20	\$24.12	\$2.81	\$96.63
For apprentice rates see "Apprentice- SHEET METAL WORKER"						
HVAC (TESTING AND BALANCING -WATER) <i>PIPEFITTERS LOCAL 537 (Local 138)</i>	03/01/2019	\$48.86	\$10.95	\$19.74	\$0.00	\$79.55
	09/01/2019	\$50.36	\$10.95	\$19.74	\$0.00	\$81.05
	03/01/2020	\$51.86	\$10.95	\$19.74	\$0.00	\$82.55
	09/01/2020	\$53.36	\$10.95	\$19.74	\$0.00	\$84.05
	03/01/2021	\$54.86	\$10.95	\$19.74	\$0.00	\$85.55
For apprentice rates see "Apprentice- PIPEFITTER" or "PLUMBER/PIPEFITTER"						
HVAC MECHANIC <i>PIPEFITTERS LOCAL 537 (Local 138)</i>	03/01/2019	\$48.86	\$10.95	\$19.74	\$0.00	\$79.55
	09/01/2019	\$50.36	\$10.95	\$19.74	\$0.00	\$81.05
	03/01/2020	\$51.86	\$10.95	\$19.74	\$0.00	\$82.55
	09/01/2020	\$53.36	\$10.95	\$19.74	\$0.00	\$84.05
	03/01/2021	\$54.86	\$10.95	\$19.74	\$0.00	\$85.55
For apprentice rates see "Apprentice- PIPEFITTER" or "PLUMBER/PIPEFITTER"						
HYDRAULIC DRILLS <i>LABORERS - ZONE 2</i>	12/01/2018	\$34.27	\$7.85	\$14.44	\$0.00	\$56.56
	06/01/2019	\$35.14	\$7.85	\$14.44	\$0.00	\$57.43
	12/01/2019	\$36.00	\$7.85	\$14.44	\$0.00	\$58.29
	06/01/2020	\$36.89	\$7.85	\$14.44	\$0.00	\$59.18
	12/01/2020	\$37.78	\$7.85	\$14.44	\$0.00	\$60.07
	06/01/2021	\$38.70	\$7.85	\$14.44	\$0.00	\$60.99
	12/01/2021	\$39.61	\$7.85	\$14.44	\$0.00	\$61.90
For apprentice rates see "Apprentice- LABORER"						
INSULATOR (PIPES & TANKS) <i>HEAT & FROST INSULATORS LOCAL 6 (BOSTON)</i>	09/01/2018	\$47.09	\$12.50	\$15.60	\$0.00	\$75.19
	09/01/2019	\$49.59	\$12.50	\$15.60	\$0.00	\$77.69

Classification

Effective Date Base Wage Health Pension Supplemental Unemployment Total Rate

Apprentice - ASBESTOS INSULATOR (Pipes & Tanks) - Local 6 Boston

Effective Date - 09/01/2018

Step	percent	Apprentice Base Wage	Health	Pension	Supplemental Unemployment	Total Rate
1	50	\$23.55	\$12.50	\$11.40	\$0.00	\$47.45
2	60	\$28.25	\$12.50	\$12.24	\$0.00	\$52.99
3	70	\$32.96	\$12.50	\$13.08	\$0.00	\$58.54
4	80	\$37.67	\$12.50	\$13.92	\$0.00	\$64.09

Effective Date - 09/01/2019

Step	percent	Apprentice Base Wage	Health	Pension	Supplemental Unemployment	Total Rate
1	50	\$24.80	\$12.50	\$11.40	\$0.00	\$48.70
2	60	\$29.75	\$12.50	\$12.24	\$0.00	\$54.49
3	70	\$34.71	\$12.50	\$13.08	\$0.00	\$60.29
4	80	\$39.67	\$12.50	\$13.92	\$0.00	\$66.09

Notes:

Steps are 1 year

Apprentice to Journeyworker Ratio:1:4

IRONWORKER/WELDER <i>IRONWORKERS LOCAL 7 (BOSTON AREA)</i>	09/16/2018	\$46.07	\$8.00	\$22.85	\$0.00	\$76.92
--	------------	---------	--------	---------	--------	---------

Apprentice - IRONWORKER - Local 7 Boston

Effective Date - 09/16/2018

Step	percent	Apprentice Base Wage	Health	Pension	Supplemental Unemployment	Total Rate
1	60	\$27.64	\$8.00	\$22.85	\$0.00	\$58.49
2	70	\$32.25	\$8.00	\$22.85	\$0.00	\$63.10
3	75	\$34.55	\$8.00	\$22.85	\$0.00	\$65.40
4	80	\$36.86	\$8.00	\$22.85	\$0.00	\$67.71
5	85	\$39.16	\$8.00	\$22.85	\$0.00	\$70.01
6	90	\$41.46	\$8.00	\$22.85	\$0.00	\$72.31

Notes:

** Structural 1:6; Ornamental 1:4

Apprentice to Journeyworker Ratio:**

JACKHAMMER & PAVING BREAKER OPERATOR <i>LABORERS - ZONE 2</i>	12/01/2018	\$33.77	\$7.85	\$14.44	\$0.00	\$56.06
	06/01/2019	\$34.64	\$7.85	\$14.44	\$0.00	\$56.93
	12/01/2019	\$35.50	\$7.85	\$14.44	\$0.00	\$57.79
	06/01/2020	\$36.39	\$7.85	\$14.44	\$0.00	\$58.68
	12/01/2020	\$37.28	\$7.85	\$14.44	\$0.00	\$59.57
	06/01/2021	\$38.20	\$7.85	\$14.44	\$0.00	\$60.49
	12/01/2021	\$39.11	\$7.85	\$14.44	\$0.00	\$61.40

For apprentice rates see "Apprentice- LABORER"

Classification	Effective Date	Base Wage	Health	Pension	Supplemental Unemployment	Total Rate
LABORER LABORERS - ZONE 2	12/01/2018	\$33.52	\$7.85	\$14.44	\$0.00	\$55.81
	06/01/2019	\$34.39	\$7.85	\$14.44	\$0.00	\$56.68
	12/01/2019	\$35.25	\$7.85	\$14.44	\$0.00	\$57.54
	06/01/2020	\$36.14	\$7.85	\$14.44	\$0.00	\$58.43
	12/01/2020	\$37.03	\$7.85	\$14.44	\$0.00	\$59.32
	06/01/2021	\$37.95	\$7.85	\$14.44	\$0.00	\$60.24
	12/01/2021	\$38.86	\$7.85	\$14.44	\$0.00	\$61.15

Apprentice - LABORER - Zone 2

Effective Date - 12/01/2018

Step	percent	Apprentice Base Wage	Health	Pension	Supplemental Unemployment	Total Rate
1	60	\$20.11	\$7.85	\$14.44	\$0.00	\$42.40
2	70	\$23.46	\$7.85	\$14.44	\$0.00	\$45.75
3	80	\$26.82	\$7.85	\$14.44	\$0.00	\$49.11
4	90	\$30.17	\$7.85	\$14.44	\$0.00	\$52.46

Effective Date - 06/01/2019

Step	percent	Apprentice Base Wage	Health	Pension	Supplemental Unemployment	Total Rate
1	60	\$20.63	\$7.85	\$14.44	\$0.00	\$42.92
2	70	\$24.07	\$7.85	\$14.44	\$0.00	\$46.36
3	80	\$27.51	\$7.85	\$14.44	\$0.00	\$49.80
4	90	\$30.95	\$7.85	\$14.44	\$0.00	\$53.24

Notes:

Apprentice to Journeyworker Ratio:1:5

LABORER: CARPENTER TENDER LABORERS - ZONE 2	12/01/2018	\$33.52	\$7.85	\$14.44	\$0.00	\$55.81
	06/01/2019	\$34.39	\$7.85	\$14.44	\$0.00	\$56.68
	12/01/2019	\$35.25	\$7.85	\$14.44	\$0.00	\$57.54
	06/01/2020	\$36.14	\$7.85	\$14.44	\$0.00	\$58.43
	12/01/2020	\$37.03	\$7.85	\$14.44	\$0.00	\$59.32
	06/01/2021	\$37.95	\$7.85	\$14.44	\$0.00	\$60.24
	12/01/2021	\$38.86	\$7.85	\$14.44	\$0.00	\$61.15

For apprentice rates see "Apprentice- LABORER"

LABORER: CEMENT FINISHER TENDER LABORERS - ZONE 2	12/01/2018	\$33.52	\$7.85	\$14.44	\$0.00	\$55.81
	06/01/2019	\$34.39	\$7.85	\$14.44	\$0.00	\$56.68
	12/01/2019	\$35.25	\$7.85	\$14.44	\$0.00	\$57.54
	06/01/2020	\$36.14	\$7.85	\$14.44	\$0.00	\$58.43
	12/01/2020	\$37.03	\$7.85	\$14.44	\$0.00	\$59.32
	06/01/2021	\$37.95	\$7.85	\$14.44	\$0.00	\$60.24
	12/01/2021	\$38.86	\$7.85	\$14.44	\$0.00	\$61.15

For apprentice rates see "Apprentice- LABORER"

LABORER: HAZARDOUS WASTE/ASBESTOS REMOVER LABORERS - ZONE 2	12/01/2018	\$33.72	\$7.85	\$14.39	\$0.00	\$55.96
	06/01/2019	\$34.59	\$7.85	\$14.39	\$0.00	\$56.83
	12/01/2019	\$35.45	\$7.85	\$14.39	\$0.00	\$57.69

Classification	Effective Date	Base Wage	Health	Pension	Supplemental Unemployment	Total Rate
For apprentice rates see "Apprentice- LABORER"						
LABORER: MASON TENDER <i>LABORERS - ZONE 2</i>	12/01/2018	\$33.77	\$7.85	\$14.44	\$0.00	\$56.06
	06/01/2019	\$34.64	\$7.85	\$14.44	\$0.00	\$56.93
	12/01/2019	\$35.50	\$7.85	\$14.44	\$0.00	\$57.79
	06/01/2020	\$36.39	\$7.85	\$14.44	\$0.00	\$58.68
	12/01/2020	\$37.28	\$7.85	\$14.44	\$0.00	\$59.57
	06/01/2021	\$38.20	\$7.85	\$14.44	\$0.00	\$60.49
	12/01/2021	\$39.11	\$7.85	\$14.44	\$0.00	\$61.40
For apprentice rates see "Apprentice- LABORER"						
LABORER: MULTI-TRADE TENDER <i>LABORERS - ZONE 2</i>	12/01/2018	\$33.52	\$7.85	\$14.44	\$0.00	\$55.81
	06/01/2019	\$34.39	\$7.85	\$14.44	\$0.00	\$56.68
	12/01/2019	\$35.25	\$7.85	\$14.44	\$0.00	\$57.54
	06/01/2020	\$36.14	\$7.85	\$14.44	\$0.00	\$58.43
	12/01/2020	\$37.03	\$7.85	\$14.44	\$0.00	\$59.32
	06/01/2021	\$37.95	\$7.85	\$14.44	\$0.00	\$60.24
	12/01/2021	\$38.86	\$7.85	\$14.44	\$0.00	\$61.15
For apprentice rates see "Apprentice- LABORER"						
LABORER: TREE REMOVER <i>LABORERS - ZONE 2</i>	12/01/2018	\$33.52	\$7.85	\$14.44	\$0.00	\$55.81
	06/01/2019	\$34.39	\$7.85	\$14.44	\$0.00	\$56.68
	12/01/2019	\$35.25	\$7.85	\$14.44	\$0.00	\$57.54
	06/01/2020	\$36.14	\$7.85	\$14.44	\$0.00	\$58.43
	12/01/2020	\$37.03	\$7.85	\$14.44	\$0.00	\$59.32
	06/01/2021	\$37.95	\$7.85	\$14.44	\$0.00	\$60.24
	12/01/2021	\$38.86	\$7.85	\$14.44	\$0.00	\$61.15
This classification applies to all tree work associated with the removal of standing trees, and trimming and removal of branches and limbs when the work is not done for a utility company for the purpose of operation, maintenance or repair of utility company equipment. For apprentice rates see "Apprentice- LABORER"						
LASER BEAM OPERATOR <i>LABORERS - ZONE 2</i>	12/01/2018	\$33.77	\$7.85	\$14.44	\$0.00	\$56.06
	06/01/2019	\$34.64	\$7.85	\$14.44	\$0.00	\$56.93
	12/01/2019	\$35.50	\$7.85	\$14.44	\$0.00	\$57.79
	06/01/2020	\$36.39	\$7.85	\$14.44	\$0.00	\$58.68
	12/01/2020	\$37.28	\$7.85	\$14.44	\$0.00	\$59.57
	06/01/2021	\$38.20	\$7.85	\$14.44	\$0.00	\$60.49
	12/01/2021	\$39.11	\$7.85	\$14.44	\$0.00	\$61.40
For apprentice rates see "Apprentice- LABORER"						
MARBLE & TILE FINISHERS <i>BRICKLAYERS LOCAL 3 - MARBLE & TILE</i>	02/01/2019	\$40.91	\$10.75	\$18.97	\$0.00	\$70.63
	08/01/2019	\$41.99	\$10.75	\$19.11	\$0.00	\$71.85
	02/01/2020	\$42.50	\$10.75	\$19.11	\$0.00	\$72.36
	08/01/2020	\$43.58	\$10.75	\$19.26	\$0.00	\$73.59
	02/01/2021	\$44.09	\$10.75	\$19.26	\$0.00	\$74.10
	08/01/2021	\$45.21	\$10.75	\$19.42	\$0.00	\$75.38
	02/01/2022	\$45.68	\$10.75	\$19.42	\$0.00	\$75.85

Apprentice - MARBLE & TILE FINISHER - Local 3 Marble & Tile

Effective Date - 02/01/2019

Step	percent	Apprentice Base Wage	Health	Pension	Supplemental Unemployment	Total Rate
1	50	\$20.46	\$10.75	\$18.97	\$0.00	\$50.18
2	60	\$24.55	\$10.75	\$18.97	\$0.00	\$54.27
3	70	\$28.64	\$10.75	\$18.97	\$0.00	\$58.36
4	80	\$32.73	\$10.75	\$18.97	\$0.00	\$62.45
5	90	\$36.82	\$10.75	\$18.97	\$0.00	\$66.54

Effective Date - 08/01/2019

Step	percent	Apprentice Base Wage	Health	Pension	Supplemental Unemployment	Total Rate
1	50	\$21.00	\$10.75	\$19.11	\$0.00	\$50.86
2	60	\$25.19	\$10.75	\$19.11	\$0.00	\$55.05
3	70	\$29.39	\$10.75	\$19.11	\$0.00	\$59.25
4	80	\$33.59	\$10.75	\$19.11	\$0.00	\$63.45
5	90	\$37.79	\$10.75	\$19.11	\$0.00	\$67.65

Notes:

Apprentice to Journeyworker Ratio:1:3

MARBLE MASONS, TILELAYERS & TERRAZZO MECH	02/01/2019	\$53.57	\$10.75	\$20.66	\$0.00	\$84.98
BRICKLAYERS LOCAL 3 - MARBLE & TILE	08/01/2019	\$54.92	\$10.75	\$20.80	\$0.00	\$86.47
	02/01/2020	\$55.55	\$10.75	\$20.80	\$0.00	\$87.10
	08/01/2020	\$56.90	\$10.75	\$20.95	\$0.00	\$88.60
	02/01/2021	\$57.54	\$10.75	\$20.95	\$0.00	\$89.24
	08/01/2021	\$58.94	\$10.75	\$21.11	\$0.00	\$90.80
	02/01/2022	\$59.51	\$10.75	\$21.11	\$0.00	\$91.37

Classification

Effective Date Base Wage Health Pension Supplemental Unemployment Total Rate

Apprentice - MARBLE-TILE-TERRAZZO MECHANIC - Local 3 Marble & Tile

Effective Date - 02/01/2019

Step	percent	Apprentice Base Wage	Health	Pension	Supplemental Unemployment	Total Rate
1	50	\$26.79	\$10.75	\$20.66	\$0.00	\$58.20
2	60	\$32.14	\$10.75	\$20.66	\$0.00	\$63.55
3	70	\$37.50	\$10.75	\$20.66	\$0.00	\$68.91
4	80	\$42.86	\$10.75	\$20.66	\$0.00	\$74.27
5	90	\$48.21	\$10.75	\$20.66	\$0.00	\$79.62

Effective Date - 08/01/2019

Step	percent	Apprentice Base Wage	Health	Pension	Supplemental Unemployment	Total Rate
1	50	\$27.46	\$10.75	\$20.80	\$0.00	\$59.01
2	60	\$32.95	\$10.75	\$20.80	\$0.00	\$64.50
3	70	\$38.44	\$10.75	\$20.80	\$0.00	\$69.99
4	80	\$43.94	\$10.75	\$20.80	\$0.00	\$75.49
5	90	\$49.43	\$10.75	\$20.80	\$0.00	\$80.98

Notes:

Apprentice to Journeyworker Ratio:1:5

MECH. SWEEPER OPERATOR (ON CONST. SITES) <i>OPERATING ENGINEERS LOCAL 4</i>	12/01/2018	\$47.10	\$11.50	\$15.60	\$0.00	\$74.20
	06/01/2019	\$48.19	\$11.50	\$15.60	\$0.00	\$75.29
	12/01/2019	\$49.33	\$11.50	\$15.60	\$0.00	\$76.43
	06/01/2020	\$50.41	\$11.50	\$15.60	\$0.00	\$77.51
	12/01/2020	\$51.55	\$11.50	\$15.60	\$0.00	\$78.65
	06/01/2021	\$52.64	\$11.50	\$15.60	\$0.00	\$79.74
	12/01/2021	\$53.78	\$11.50	\$15.60	\$0.00	\$80.88

For apprentice rates see "Apprentice- OPERATING ENGINEERS"

MECHANICS MAINTENANCE <i>OPERATING ENGINEERS LOCAL 4</i>	12/01/2018	\$47.10	\$11.50	\$15.60	\$0.00	\$74.20
	06/01/2019	\$48.19	\$11.50	\$15.60	\$0.00	\$75.29
	12/01/2019	\$49.33	\$11.50	\$15.60	\$0.00	\$76.43
	06/01/2020	\$50.41	\$11.50	\$15.60	\$0.00	\$77.51
	12/01/2020	\$51.55	\$11.50	\$15.60	\$0.00	\$78.65
	06/01/2021	\$52.64	\$11.50	\$15.60	\$0.00	\$79.74
	12/01/2021	\$53.78	\$11.50	\$15.60	\$0.00	\$80.88

For apprentice rates see "Apprentice- OPERATING ENGINEERS"

MILLWRIGHT (Zone 2) <i>MILLWRIGHTS LOCAL 1121 - Zone 2</i>	04/01/2019	\$38.87	\$9.90	\$18.50	\$0.00	\$67.27
---	------------	---------	--------	---------	--------	---------

Apprentice - MILLWRIGHT - Local 1121 Zone 2

Effective Date - 04/01/2019

Step	percent	Apprentice Base Wage	Health	Pension	Supplemental Unemployment	Total Rate
1	55	\$21.38	\$9.90	\$5.31	\$0.00	\$36.59
2	65	\$25.27	\$9.90	\$15.13	\$0.00	\$50.30
3	75	\$29.15	\$9.90	\$16.10	\$0.00	\$55.15
4	85	\$33.04	\$9.90	\$17.06	\$0.00	\$60.00

Notes:
Steps are 2,000 hours

Apprentice to Journeyworker Ratio:1:5

MORTAR MIXER <i>LABORERS - ZONE 2</i>	12/01/2018	\$33.77	\$7.85	\$14.44	\$0.00	\$56.06
	06/01/2019	\$34.64	\$7.85	\$14.44	\$0.00	\$56.93
	12/01/2019	\$35.50	\$7.85	\$14.44	\$0.00	\$57.79
	06/01/2020	\$36.39	\$7.85	\$14.44	\$0.00	\$58.68
	12/01/2020	\$37.28	\$7.85	\$14.44	\$0.00	\$59.57
	06/01/2021	\$38.20	\$7.85	\$14.44	\$0.00	\$60.49
	12/01/2021	\$39.11	\$7.85	\$14.44	\$0.00	\$61.40

For apprentice rates see "Apprentice- LABORER"

OILER (OTHER THAN TRUCK CRANES,GRADALLS) <i>OPERATING ENGINEERS LOCAL 4</i>	12/01/2018	\$23.06	\$11.50	\$15.60	\$0.00	\$50.16
	06/01/2019	\$23.61	\$11.50	\$15.60	\$0.00	\$50.71
	12/01/2019	\$24.18	\$11.50	\$15.60	\$0.00	\$51.28
	06/01/2020	\$24.73	\$11.50	\$15.60	\$0.00	\$51.83
	12/01/2020	\$25.30	\$11.50	\$15.60	\$0.00	\$52.40
	06/01/2021	\$25.85	\$11.50	\$15.60	\$0.00	\$52.95
	12/01/2021	\$26.43	\$11.50	\$15.60	\$0.00	\$53.53

For apprentice rates see "Apprentice- OPERATING ENGINEERS"

OILER (TRUCK CRANES, GRADALLS) <i>OPERATING ENGINEERS LOCAL 4</i>	12/01/2018	\$27.42	\$11.50	\$15.60	\$0.00	\$54.52
	06/01/2019	\$28.07	\$11.50	\$15.60	\$0.00	\$55.17
	12/01/2019	\$28.74	\$11.50	\$15.60	\$0.00	\$55.84
	06/01/2020	\$29.39	\$11.50	\$15.60	\$0.00	\$56.49
	12/01/2020	\$30.07	\$11.50	\$15.60	\$0.00	\$57.17
	06/01/2021	\$30.71	\$11.50	\$15.60	\$0.00	\$57.81
	12/01/2021	\$31.39	\$11.50	\$15.60	\$0.00	\$58.49

For apprentice rates see "Apprentice- OPERATING ENGINEERS"

OTHER POWER DRIVEN EQUIPMENT - CLASS II <i>OPERATING ENGINEERS LOCAL 4</i>	12/01/2018	\$47.10	\$11.50	\$15.60	\$0.00	\$74.20
	06/01/2019	\$48.19	\$11.50	\$15.60	\$0.00	\$75.29
	12/01/2019	\$49.33	\$11.50	\$15.60	\$0.00	\$76.43
	06/01/2020	\$50.41	\$11.50	\$15.60	\$0.00	\$77.51
	12/01/2020	\$51.55	\$11.50	\$15.60	\$0.00	\$78.65
	06/01/2021	\$52.64	\$11.50	\$15.60	\$0.00	\$79.74
	12/01/2021	\$53.78	\$11.50	\$15.60	\$0.00	\$80.88

For apprentice rates see "Apprentice- OPERATING ENGINEERS"

Classification	Effective Date	Base Wage	Health	Pension	Supplemental Unemployment	Total Rate
PAINTER (BRIDGES/TANKS) <i>PAINTERS LOCAL 35 - ZONE 2</i>	01/01/2019	\$50.36	\$8.15	\$20.85	\$0.00	\$79.36
	07/01/2019	\$51.46	\$8.15	\$20.85	\$0.00	\$80.46
	01/01/2020	\$52.56	\$8.15	\$20.85	\$0.00	\$81.56
	07/01/2020	\$53.66	\$8.15	\$20.85	\$0.00	\$82.66
	01/01/2021	\$54.76	\$8.15	\$20.85	\$0.00	\$83.76

Apprentice - PAINTER Local 35 - BRIDGES/TANKS

Effective Date - 01/01/2019

Step	percent	Apprentice Base Wage	Health	Pension	Supplemental Unemployment	Total Rate
1	50	\$25.18	\$8.15	\$0.00	\$0.00	\$33.33
2	55	\$27.70	\$8.15	\$5.64	\$0.00	\$41.49
3	60	\$30.22	\$8.15	\$6.15	\$0.00	\$44.52
4	65	\$32.73	\$8.15	\$6.66	\$0.00	\$47.54
5	70	\$35.25	\$8.15	\$17.78	\$0.00	\$61.18
6	75	\$37.77	\$8.15	\$18.29	\$0.00	\$64.21
7	80	\$40.29	\$8.15	\$18.80	\$0.00	\$67.24
8	90	\$45.32	\$8.15	\$19.83	\$0.00	\$73.30

Effective Date - 07/01/2019

Step	percent	Apprentice Base Wage	Health	Pension	Supplemental Unemployment	Total Rate
1	50	\$25.73	\$8.15	\$0.00	\$0.00	\$33.88
2	55	\$28.30	\$8.15	\$5.64	\$0.00	\$42.09
3	60	\$30.88	\$8.15	\$6.15	\$0.00	\$45.18
4	65	\$33.45	\$8.15	\$6.66	\$0.00	\$48.26
5	70	\$36.02	\$8.15	\$17.78	\$0.00	\$61.95
6	75	\$38.60	\$8.15	\$18.29	\$0.00	\$65.04
7	80	\$41.17	\$8.15	\$18.80	\$0.00	\$68.12
8	90	\$46.31	\$8.15	\$19.83	\$0.00	\$74.29

Notes:

Steps are 750 hrs.

Apprentice to Journeyworker Ratio:1:1

PAINTER (SIGN, PICTORIAL & DISPLAY) <i>PAINTERS LOCAL 35 - ZONE 2</i>	06/01/2013	\$25.81	\$7.07	\$7.05	\$0.00	\$39.93
--	------------	---------	--------	--------	--------	---------

Classification

Effective Date Base Wage Health Pension Supplemental Unemployment Total Rate

Apprentice - PAINTER SIGN - Local 35 Zone 2

Effective Date - 06/01/2013

Step	percent	Apprentice Base Wage	Health	Pension	Supplemental Unemployment	Total Rate
1	50	\$12.91	\$7.07	\$0.00	\$0.00	\$19.98
2	55	\$14.20	\$7.07	\$2.45	\$0.00	\$23.72
3	60	\$15.49	\$7.07	\$2.45	\$0.00	\$25.01
4	65	\$16.78	\$7.07	\$2.45	\$0.00	\$26.30
5	70	\$18.07	\$7.07	\$7.05	\$0.00	\$32.19
6	75	\$19.36	\$7.07	\$7.05	\$0.00	\$33.48
7	80	\$20.65	\$7.07	\$7.05	\$0.00	\$34.77
8	85	\$21.94	\$7.07	\$7.05	\$0.00	\$36.06
9	90	\$23.23	\$7.07	\$7.05	\$0.00	\$37.35

Notes:
Steps are 4 mos.

Apprentice to Journeyworker Ratio:1:1

PAINTER (SPRAY OR SANDBLAST, NEW) *	01/01/2019	\$41.26	\$8.15	\$20.85	\$0.00	\$70.26
* If 30% or more of surfaces to be painted are new construction, NEW paint rate shall be used. PAINTERS LOCAL 35 - ZONE 2	07/01/2019	\$42.36	\$8.15	\$20.85	\$0.00	\$71.36
	01/01/2020	\$43.46	\$8.15	\$20.85	\$0.00	\$72.46
	07/01/2020	\$44.56	\$8.15	\$20.85	\$0.00	\$73.56
	01/01/2021	\$45.66	\$8.15	\$20.85	\$0.00	\$74.66

Classification

Effective Date Base Wage Health Pension Supplemental Unemployment Total Rate

Apprentice - PAINTER Local 35 Zone 2 - Spray/Sandblast - New

Effective Date - 01/01/2019

Step	percent	Apprentice Base Wage	Health	Pension	Supplemental Unemployment	Total Rate
1	50	\$20.63	\$8.15	\$0.00	\$0.00	\$28.78
2	55	\$22.69	\$8.15	\$5.64	\$0.00	\$36.48
3	60	\$24.76	\$8.15	\$6.15	\$0.00	\$39.06
4	65	\$26.82	\$8.15	\$6.66	\$0.00	\$41.63
5	70	\$28.88	\$8.15	\$17.78	\$0.00	\$54.81
6	75	\$30.95	\$8.15	\$18.29	\$0.00	\$57.39
7	80	\$33.01	\$8.15	\$18.80	\$0.00	\$59.96
8	90	\$37.13	\$8.15	\$19.83	\$0.00	\$65.11

Effective Date - 07/01/2019

Step	percent	Apprentice Base Wage	Health	Pension	Supplemental Unemployment	Total Rate
1	50	\$21.18	\$8.15	\$0.00	\$0.00	\$29.33
2	55	\$23.30	\$8.15	\$5.64	\$0.00	\$37.09
3	60	\$25.42	\$8.15	\$6.15	\$0.00	\$39.72
4	65	\$27.53	\$8.15	\$6.66	\$0.00	\$42.34
5	70	\$29.65	\$8.15	\$17.78	\$0.00	\$55.58
6	75	\$31.77	\$8.15	\$18.29	\$0.00	\$58.21
7	80	\$33.89	\$8.15	\$18.80	\$0.00	\$60.84
8	90	\$38.12	\$8.15	\$19.83	\$0.00	\$66.10

Notes:

Steps are 750 hrs.

Apprentice to Journeyworker Ratio:1:1

PAINTER (SPRAY OR SANDBLAST, REPAINT)	01/01/2019	\$39.32	\$8.15	\$20.85	\$0.00	\$68.32
PAINTERS LOCAL 35 - ZONE 2	07/01/2019	\$40.42	\$8.15	\$20.85	\$0.00	\$69.42
	01/01/2020	\$41.52	\$8.15	\$20.85	\$0.00	\$70.52
	07/01/2020	\$42.62	\$8.15	\$20.85	\$0.00	\$71.62
	01/01/2021	\$43.72	\$8.15	\$20.85	\$0.00	\$72.72

Classification

Effective Date Base Wage Health Pension Supplemental Unemployment Total Rate

Apprentice - PAINTER Local 35 Zone 2 - Spray/Sandblast - Repaint

Effective Date - 01/01/2019

Step	percent	Apprentice Base Wage	Health	Pension	Supplemental Unemployment	Total Rate
1	50	\$19.66	\$8.15	\$0.00	\$0.00	\$27.81
2	55	\$21.63	\$8.15	\$5.64	\$0.00	\$35.42
3	60	\$23.59	\$8.15	\$6.15	\$0.00	\$37.89
4	65	\$25.56	\$8.15	\$6.66	\$0.00	\$40.37
5	70	\$27.52	\$8.15	\$17.78	\$0.00	\$53.45
6	75	\$29.49	\$8.15	\$18.29	\$0.00	\$55.93
7	80	\$31.46	\$8.15	\$18.80	\$0.00	\$58.41
8	90	\$35.39	\$8.15	\$19.83	\$0.00	\$63.37

Effective Date - 07/01/2019

Step	percent	Apprentice Base Wage	Health	Pension	Supplemental Unemployment	Total Rate
1	50	\$20.21	\$8.15	\$0.00	\$0.00	\$28.36
2	55	\$22.23	\$8.15	\$5.64	\$0.00	\$36.02
3	60	\$24.25	\$8.15	\$6.15	\$0.00	\$38.55
4	65	\$26.27	\$8.15	\$6.66	\$0.00	\$41.08
5	70	\$28.29	\$8.15	\$17.78	\$0.00	\$54.22
6	75	\$30.32	\$8.15	\$18.29	\$0.00	\$56.76
7	80	\$32.34	\$8.15	\$18.80	\$0.00	\$59.29
8	90	\$36.38	\$8.15	\$19.83	\$0.00	\$64.36

Notes:

Steps are 750 hrs.

Apprentice to Journeyworker Ratio:1:1

PAINTER (TRAFFIC MARKINGS)	12/01/2018	\$33.52	\$7.85	\$14.44	\$0.00	\$55.81
LABORERS - ZONE 2	06/01/2019	\$34.39	\$7.85	\$14.44	\$0.00	\$56.68
	12/01/2019	\$35.25	\$7.85	\$14.44	\$0.00	\$57.54
	06/01/2020	\$36.14	\$7.85	\$14.44	\$0.00	\$58.43
	12/01/2020	\$37.03	\$7.85	\$14.44	\$0.00	\$59.32
	06/01/2021	\$37.95	\$7.85	\$14.44	\$0.00	\$60.24
	12/01/2021	\$38.86	\$7.85	\$14.44	\$0.00	\$61.15

For Apprentice rates see "Apprentice- LABORER"

PAINTER / TAPER (BRUSH, NEW) *	01/01/2019	\$39.86	\$8.15	\$20.85	\$0.00	\$68.86
* If 30% or more of surfaces to be painted are new construction, NEW paint rate shall be used. PAINTERS LOCAL 35 - ZONE 2	07/01/2019	\$40.96	\$8.15	\$20.85	\$0.00	\$69.96
	01/01/2020	\$42.06	\$8.15	\$20.85	\$0.00	\$71.06
	07/01/2020	\$43.16	\$8.15	\$20.85	\$0.00	\$72.16
	01/01/2021	\$44.25	\$8.15	\$20.85	\$0.00	\$73.25

Classification

Effective Date Base Wage Health Pension Supplemental Unemployment Total Rate

Apprentice - PAINTER - Local 35 Zone 2 - BRUSH NEW

Effective Date - 01/01/2019

Step	percent	Apprentice Base Wage	Health	Pension	Supplemental Unemployment	Total Rate
1	50	\$19.93	\$8.15	\$0.00	\$0.00	\$28.08
2	55	\$21.92	\$8.15	\$5.64	\$0.00	\$35.71
3	60	\$23.92	\$8.15	\$6.15	\$0.00	\$38.22
4	65	\$25.91	\$8.15	\$6.66	\$0.00	\$40.72
5	70	\$27.90	\$8.15	\$17.78	\$0.00	\$53.83
6	75	\$29.90	\$8.15	\$18.29	\$0.00	\$56.34
7	80	\$31.89	\$8.15	\$18.80	\$0.00	\$58.84
8	90	\$35.87	\$8.15	\$19.83	\$0.00	\$63.85

Effective Date - 07/01/2019

Step	percent	Apprentice Base Wage	Health	Pension	Supplemental Unemployment	Total Rate
1	50	\$20.48	\$8.15	\$0.00	\$0.00	\$28.63
2	55	\$22.53	\$8.15	\$5.64	\$0.00	\$36.32
3	60	\$24.58	\$8.15	\$6.15	\$0.00	\$38.88
4	65	\$26.62	\$8.15	\$6.66	\$0.00	\$41.43
5	70	\$28.67	\$8.15	\$17.78	\$0.00	\$54.60
6	75	\$30.72	\$8.15	\$18.29	\$0.00	\$57.16
7	80	\$32.77	\$8.15	\$18.80	\$0.00	\$59.72
8	90	\$36.86	\$8.15	\$19.83	\$0.00	\$64.84

Notes:
Steps are 750 hrs.

Apprentice to Journeyworker Ratio:1:1

PAINTER / TAPER (BRUSH, REPAINT)	01/01/2019	\$37.92	\$8.15	\$20.85	\$0.00	\$66.92
PAINTERS LOCAL 35 - ZONE 2	07/01/2019	\$39.02	\$8.15	\$20.85	\$0.00	\$68.02
	01/01/2020	\$40.12	\$8.15	\$20.85	\$0.00	\$69.12
	07/01/2020	\$41.22	\$8.15	\$20.85	\$0.00	\$70.22
	01/01/2021	\$42.32	\$8.15	\$20.85	\$0.00	\$71.32

Classification

Effective Date Base Wage Health Pension Supplemental Unemployment Total Rate

Apprentice - PAINTER Local 35 Zone 2 - BRUSH REPAINT

Effective Date - 01/01/2019

Step	percent	Apprentice Base Wage	Health	Pension	Supplemental Unemployment	Total Rate
1	50	\$18.96	\$8.15	\$0.00	\$0.00	\$27.11
2	55	\$20.86	\$8.15	\$5.64	\$0.00	\$34.65
3	60	\$22.75	\$8.15	\$6.15	\$0.00	\$37.05
4	65	\$24.65	\$8.15	\$6.66	\$0.00	\$39.46
5	70	\$26.54	\$8.15	\$17.78	\$0.00	\$52.47
6	75	\$28.44	\$8.15	\$18.29	\$0.00	\$54.88
7	80	\$30.34	\$8.15	\$18.80	\$0.00	\$57.29
8	90	\$34.13	\$8.15	\$19.83	\$0.00	\$62.11

Effective Date - 07/01/2019

Step	percent	Apprentice Base Wage	Health	Pension	Supplemental Unemployment	Total Rate
1	50	\$19.51	\$8.15	\$0.00	\$0.00	\$27.66
2	55	\$21.46	\$8.15	\$5.64	\$0.00	\$35.25
3	60	\$23.41	\$8.15	\$6.15	\$0.00	\$37.71
4	65	\$25.36	\$8.15	\$6.66	\$0.00	\$40.17
5	70	\$27.31	\$8.15	\$17.78	\$0.00	\$53.24
6	75	\$29.27	\$8.15	\$18.29	\$0.00	\$55.71
7	80	\$31.22	\$8.15	\$18.80	\$0.00	\$58.17
8	90	\$35.12	\$8.15	\$19.83	\$0.00	\$63.10

Notes:

Steps are 750 hrs.

Apprentice to Journeyworker Ratio:1:1

PANEL & PICKUP TRUCKS DRIVER <i>TEAMSTERS JOINT COUNCIL NO. 10 ZONE B</i>	12/01/2018	\$33.08	\$11.91	\$12.70	\$0.00	\$57.69
	06/01/2019	\$34.08	\$11.91	\$12.70	\$0.00	\$58.69
	08/01/2019	\$34.08	\$12.41	\$12.70	\$0.00	\$59.19
	12/01/2019	\$34.08	\$12.41	\$13.72	\$0.00	\$60.21
	06/01/2020	\$34.98	\$12.41	\$13.72	\$0.00	\$61.11
	08/01/2020	\$34.98	\$12.91	\$13.72	\$0.00	\$61.61
	12/01/2020	\$34.98	\$12.91	\$14.82	\$0.00	\$62.71
	06/01/2021	\$35.78	\$12.91	\$14.82	\$0.00	\$63.51
	08/01/2021	\$35.78	\$13.41	\$14.82	\$0.00	\$64.01
	12/01/2021	\$35.78	\$13.41	\$16.01	\$0.00	\$65.20
PIER AND DOCK CONSTRUCTOR (UNDERPINNING AND DECK) <i>PILE DRIVER LOCAL 56 (ZONE 1)</i>	08/01/2018	\$46.57	\$9.90	\$21.15	\$0.00	\$77.62
<i>For apprentice rates see "Apprentice- PILE DRIVER"</i>	08/01/2019	\$48.94	\$9.90	\$21.15	\$0.00	\$79.99
PILE DRIVER <i>PILE DRIVER LOCAL 56 (ZONE 1)</i>	08/01/2018	\$46.57	\$9.90	\$21.15	\$0.00	\$77.62
	08/01/2019	\$48.94	\$9.90	\$21.15	\$0.00	\$79.99

Classification

Effective Date Base Wage Health Pension Supplemental Unemployment Total Rate

Apprentice - PILE DRIVER - Local 56 Zone 1

Effective Date - 08/01/2018

Step	percent	Apprentice Base Wage	Health	Pension	Supplemental Unemployment	Total Rate
1	50	\$23.29	\$9.90	\$21.15	\$0.00	\$54.34
2	60	\$27.94	\$9.90	\$21.15	\$0.00	\$58.99
3	70	\$32.60	\$9.90	\$21.15	\$0.00	\$63.65
4	75	\$34.93	\$9.90	\$21.15	\$0.00	\$65.98
5	80	\$37.26	\$9.90	\$21.15	\$0.00	\$68.31
6	80	\$37.26	\$9.90	\$21.15	\$0.00	\$68.31
7	90	\$41.91	\$9.90	\$21.15	\$0.00	\$72.96
8	90	\$41.91	\$9.90	\$21.15	\$0.00	\$72.96

Effective Date - 08/01/2019

Step	percent	Apprentice Base Wage	Health	Pension	Supplemental Unemployment	Total Rate
1	50	\$24.47	\$9.90	\$21.15	\$0.00	\$55.52
2	60	\$29.36	\$9.90	\$21.15	\$0.00	\$60.41
3	70	\$34.26	\$9.90	\$21.15	\$0.00	\$65.31
4	75	\$36.71	\$9.90	\$21.15	\$0.00	\$67.76
5	80	\$39.15	\$9.90	\$21.15	\$0.00	\$70.20
6	80	\$39.15	\$9.90	\$21.15	\$0.00	\$70.20
7	90	\$44.05	\$9.90	\$21.15	\$0.00	\$75.10
8	90	\$44.05	\$9.90	\$21.15	\$0.00	\$75.10

Notes:

Apprentice to Journeyworker Ratio:1:5

PIPEFITTER & STEAMFITTER	03/01/2019	\$48.86	\$10.95	\$19.74	\$0.00	\$79.55
PIPEFITTERS LOCAL 537 (Local 138)	09/01/2019	\$50.36	\$10.95	\$19.74	\$0.00	\$81.05
	03/01/2020	\$51.86	\$10.95	\$19.74	\$0.00	\$82.55
	09/01/2020	\$53.36	\$10.95	\$19.74	\$0.00	\$84.05
	03/01/2021	\$54.86	\$10.95	\$19.74	\$0.00	\$85.55

Classification

Effective Date Base Wage Health Pension Supplemental Unemployment Total Rate

Apprentice - PIPEFITTER Local 537 (Local 138)

Effective Date - 03/01/2019

Step	percent	Apprentice Base Wage	Health	Pension	Supplemental Unemployment	Total Rate
1	40	\$19.54	\$10.95	\$8.00	\$0.00	\$38.49
2	45	\$21.99	\$10.95	\$19.74	\$0.00	\$52.68
3	60	\$29.32	\$10.95	\$19.74	\$0.00	\$60.01
4	70	\$34.20	\$10.95	\$19.74	\$0.00	\$64.89
5	80	\$39.09	\$10.95	\$19.74	\$0.00	\$69.78

Effective Date - 09/01/2019

Step	percent	Apprentice Base Wage	Health	Pension	Supplemental Unemployment	Total Rate
1	40	\$20.14	\$10.95	\$8.00	\$0.00	\$39.09
2	45	\$22.66	\$10.95	\$19.74	\$0.00	\$53.35
3	60	\$30.22	\$10.95	\$19.74	\$0.00	\$60.91
4	70	\$35.25	\$10.95	\$19.74	\$0.00	\$65.94
5	80	\$40.29	\$10.95	\$19.74	\$0.00	\$70.98

Notes:

** 1:3; 3:15; 1:10 thereafter / Steps are 1 yr.
 Refrig/AC Mechanic **1:1;1:2;2:4;3:6;4:8;5:10;6:12;7:14;8:17;9:20;10:23(Max)

Apprentice to Journeyworker Ratio:**

PIPELAYER	12/01/2018	\$33.77	\$7.85	\$14.44	\$0.00	\$56.06
LABORERS - ZONE 2	06/01/2019	\$34.64	\$7.85	\$14.44	\$0.00	\$56.93
	12/01/2019	\$35.50	\$7.85	\$14.44	\$0.00	\$57.79
	06/01/2020	\$36.39	\$7.85	\$14.44	\$0.00	\$58.68
	12/01/2020	\$37.28	\$7.85	\$14.44	\$0.00	\$59.57
	06/01/2021	\$38.20	\$7.85	\$14.44	\$0.00	\$60.49
	12/01/2021	\$39.11	\$7.85	\$14.44	\$0.00	\$61.40

For apprentice rates see "Apprentice- LABORER"

PLUMBER	03/01/2019	\$52.61	\$11.82	\$16.51	\$0.00	\$80.94
PLUMBERS & GASFITTERS LOCAL 12 (Local 138)	09/01/2019	\$54.11	\$11.82	\$16.51	\$0.00	\$82.44
	03/01/2020	\$55.61	\$11.82	\$16.51	\$0.00	\$83.94
	09/01/2020	\$57.11	\$11.82	\$16.51	\$0.00	\$85.44
	03/01/2021	\$58.61	\$11.82	\$16.51	\$0.00	\$86.94

Classification

Effective Date Base Wage Health Pension Supplemental Unemployment Total Rate

Apprentice - PLUMBER/GASFITTER - Local 12 (Local 138)

Effective Date - 03/01/2019

Step	percent	Apprentice Base Wage	Health	Pension	Supplemental Unemployment	Total Rate
1	35	\$18.41	\$11.82	\$5.98	\$0.00	\$36.21
2	40	\$21.04	\$11.82	\$6.79	\$0.00	\$39.65
3	55	\$28.94	\$11.82	\$9.25	\$0.00	\$50.01
4	65	\$34.20	\$11.82	\$10.85	\$0.00	\$56.87
5	75	\$39.46	\$11.82	\$12.50	\$0.00	\$63.78

Effective Date - 09/01/2019

Step	percent	Apprentice Base Wage	Health	Pension	Supplemental Unemployment	Total Rate
1	35	\$18.94	\$11.82	\$5.98	\$0.00	\$36.74
2	40	\$21.64	\$11.82	\$6.79	\$0.00	\$40.25
3	55	\$29.76	\$11.82	\$9.25	\$0.00	\$50.83
4	65	\$35.17	\$11.82	\$10.85	\$0.00	\$57.84
5	75	\$40.58	\$11.82	\$12.50	\$0.00	\$64.90

Notes:

Steps are 1 yr
Step 4 with lic\$60.32, Step5 with lic\$67.17

Apprentice to Journeyworker Ratio:1:5

PNEUMATIC CONTROLS (TEMP.)	03/01/2019	\$48.86	\$10.95	\$19.74	\$0.00	\$79.55
PIPEFITTERS LOCAL 537 (Local 138)	09/01/2019	\$50.36	\$10.95	\$19.74	\$0.00	\$81.05
	03/01/2020	\$51.86	\$10.95	\$19.74	\$0.00	\$82.55
	09/01/2020	\$53.36	\$10.95	\$19.74	\$0.00	\$84.05
	03/01/2021	\$54.86	\$10.95	\$19.74	\$0.00	\$85.55

For apprentice rates see "Apprentice- PIPEFITTER" or "PLUMBER/PIPEFITTER"

PNEUMATIC DRILL/TOOL OPERATOR	12/01/2018	\$33.77	\$7.85	\$14.44	\$0.00	\$56.06
LABORERS - ZONE 2	06/01/2019	\$34.64	\$7.85	\$14.44	\$0.00	\$56.93
	12/01/2019	\$35.50	\$7.85	\$14.44	\$0.00	\$57.79
	06/01/2020	\$36.39	\$7.85	\$14.44	\$0.00	\$58.68
	12/01/2020	\$37.28	\$7.85	\$14.44	\$0.00	\$59.57
	06/01/2021	\$38.20	\$7.85	\$14.44	\$0.00	\$60.49
	12/01/2021	\$39.11	\$7.85	\$14.44	\$0.00	\$61.40

For apprentice rates see "Apprentice- LABORER"

POWDERMAN & BLASTER	12/01/2018	\$34.52	\$7.85	\$14.44	\$0.00	\$56.81
LABORERS - ZONE 2	06/01/2019	\$35.39	\$7.85	\$14.44	\$0.00	\$57.68
	12/01/2019	\$36.25	\$7.85	\$14.44	\$0.00	\$58.54
	06/01/2020	\$37.14	\$7.85	\$14.44	\$0.00	\$59.43
	12/01/2020	\$38.03	\$7.85	\$14.44	\$0.00	\$60.32
	06/01/2021	\$38.95	\$7.85	\$14.44	\$0.00	\$61.24
	12/01/2021	\$39.86	\$7.85	\$14.44	\$0.00	\$62.15

For apprentice rates see "Apprentice- LABORER"

Classification	Effective Date	Base Wage	Health	Pension	Supplemental Unemployment	Total Rate
POWER SHOVEL/DERRICK/TRENCHING MACHINE <i>OPERATING ENGINEERS LOCAL 4</i>	12/01/2018	\$47.58	\$11.50	\$15.60	\$0.00	\$74.68
	06/01/2019	\$48.68	\$11.50	\$15.60	\$0.00	\$75.78
	12/01/2019	\$49.83	\$11.50	\$15.60	\$0.00	\$76.93
	06/01/2020	\$50.93	\$11.50	\$15.60	\$0.00	\$78.03
	12/01/2020	\$52.08	\$11.50	\$15.60	\$0.00	\$79.18
	06/01/2021	\$53.18	\$11.50	\$15.60	\$0.00	\$80.28
	12/01/2021	\$54.33	\$11.50	\$15.60	\$0.00	\$81.43
For apprentice rates see "Apprentice- OPERATING ENGINEERS"						
PUMP OPERATOR (CONCRETE) <i>OPERATING ENGINEERS LOCAL 4</i>	12/01/2018	\$47.58	\$11.50	\$15.60	\$0.00	\$74.68
	06/01/2019	\$48.68	\$11.50	\$15.60	\$0.00	\$75.78
	12/01/2019	\$49.83	\$11.50	\$15.60	\$0.00	\$76.93
	06/01/2020	\$50.93	\$11.50	\$15.60	\$0.00	\$78.03
	12/01/2020	\$52.08	\$11.50	\$15.60	\$0.00	\$79.18
	06/01/2021	\$53.18	\$11.50	\$15.60	\$0.00	\$80.28
	12/01/2021	\$54.33	\$11.50	\$15.60	\$0.00	\$81.43
For apprentice rates see "Apprentice- OPERATING ENGINEERS"						
PUMP OPERATOR (DEWATERING, OTHER) <i>OPERATING ENGINEERS LOCAL 4</i>	12/01/2018	\$32.03	\$11.50	\$15.60	\$0.00	\$59.13
	06/01/2019	\$32.78	\$11.50	\$15.60	\$0.00	\$59.88
	12/01/2019	\$33.57	\$11.50	\$15.60	\$0.00	\$60.67
	06/01/2020	\$34.32	\$11.50	\$15.60	\$0.00	\$61.42
	12/01/2020	\$35.10	\$11.50	\$15.60	\$0.00	\$62.20
	06/01/2021	\$35.85	\$11.50	\$15.60	\$0.00	\$62.95
	12/01/2021	\$36.64	\$11.50	\$15.60	\$0.00	\$63.74
For apprentice rates see "Apprentice- OPERATING ENGINEERS"						
READY-MIX CONCRETE DRIVER <i>TEAMSTERS LOCAL 42</i>	05/01/2018	\$24.24	\$8.49	\$12.46	\$0.00	\$45.19
	04/30/2019	\$24.24	\$8.49	\$12.92	\$0.00	\$45.65
RECLAIMERS <i>OPERATING ENGINEERS LOCAL 4</i>	12/01/2018	\$47.10	\$11.50	\$15.60	\$0.00	\$74.20
	06/01/2019	\$48.19	\$11.50	\$15.60	\$0.00	\$75.29
	12/01/2019	\$49.33	\$11.50	\$15.60	\$0.00	\$76.43
	06/01/2020	\$50.41	\$11.50	\$15.60	\$0.00	\$77.51
	12/01/2020	\$51.55	\$11.50	\$15.60	\$0.00	\$78.65
	06/01/2021	\$52.64	\$11.50	\$15.60	\$0.00	\$79.74
	12/01/2021	\$53.78	\$11.50	\$15.60	\$0.00	\$80.88
For apprentice rates see "Apprentice- OPERATING ENGINEERS"						
RIDE-ON MOTORIZED BUGGY OPERATOR <i>LABORERS - ZONE 2</i>	12/01/2018	\$33.77	\$7.85	\$14.44	\$0.00	\$56.06
	06/01/2019	\$34.64	\$7.85	\$14.44	\$0.00	\$56.93
	12/01/2019	\$35.50	\$7.85	\$14.44	\$0.00	\$57.79
	06/01/2020	\$36.39	\$7.85	\$14.44	\$0.00	\$58.68
	12/01/2020	\$37.28	\$7.85	\$14.44	\$0.00	\$59.57
	06/01/2021	\$38.20	\$7.85	\$14.44	\$0.00	\$60.49
	12/01/2021	\$39.11	\$7.85	\$14.44	\$0.00	\$61.40
For apprentice rates see "Apprentice- LABORER"						

Classification	Effective Date	Base Wage	Health	Pension	Supplemental Unemployment	Total Rate
ROLLER/SPREADER/MULCHING MACHINE <i>OPERATING ENGINEERS LOCAL 4</i>	12/01/2018	\$47.10	\$11.50	\$15.60	\$0.00	\$74.20
	06/01/2019	\$48.19	\$11.50	\$15.60	\$0.00	\$75.29
	12/01/2019	\$49.33	\$11.50	\$15.60	\$0.00	\$76.43
	06/01/2020	\$50.41	\$11.50	\$15.60	\$0.00	\$77.51
	12/01/2020	\$51.55	\$11.50	\$15.60	\$0.00	\$78.65
	06/01/2021	\$52.64	\$11.50	\$15.60	\$0.00	\$79.74
	12/01/2021	\$53.78	\$11.50	\$15.60	\$0.00	\$80.88
For apprentice rates see "Apprentice- OPERATING ENGINEERS"						
ROOFER (Inc.Roofing Waterproofing &Roofing Damproofg) <i>ROOFERS LOCAL 33</i>	02/01/2019	\$43.36	\$11.50	\$15.90	\$0.00	\$70.76

Apprentice - ROOFER - Local 33

Effective Date - 02/01/2019

Step	percent	Apprentice Base Wage	Health	Pension	Supplemental Unemployment	Total Rate
1	50	\$21.68	\$11.50	\$3.69	\$0.00	\$36.87
2	60	\$26.02	\$11.50	\$15.90	\$0.00	\$53.42
3	65	\$28.18	\$11.50	\$15.90	\$0.00	\$55.58
4	75	\$32.52	\$11.50	\$15.90	\$0.00	\$59.92
5	85	\$36.86	\$11.50	\$15.90	\$0.00	\$64.26

Notes: ** 1:5, 2:6-10, the 1:10; Reroofing: 1:4, then 1:1
 Step 1 is 2000 hrs.; Steps 2-5 are 1000 hrs.
 (Hot Pitch Mechanics' receive \$1.00 hr. above ROOFER)

Apprentice to Journeyworker Ratio:**

ROOFER SLATE / TILE / PRECAST CONCRETE <i>ROOFERS LOCAL 33</i>	02/01/2019	\$43.61	\$11.50	\$15.90	\$0.00	\$71.01
For apprentice rates see "Apprentice- ROOFER"						
SHEETMETAL WORKER <i>SHEETMETAL WORKERS LOCAL 17 - A</i>	02/01/2019	\$46.50	\$13.20	\$24.12	\$2.52	\$86.34
	08/01/2019	\$48.10	\$13.20	\$24.12	\$2.56	\$87.98
	02/01/2020	\$49.75	\$13.20	\$24.12	\$2.61	\$89.68
	08/01/2020	\$51.35	\$13.20	\$24.12	\$2.66	\$91.33
	02/01/2021	\$53.00	\$13.20	\$24.12	\$2.71	\$93.03
	08/01/2021	\$54.75	\$13.20	\$24.12	\$2.76	\$94.83
	02/01/2022	\$56.50	\$13.20	\$24.12	\$2.81	\$96.63

Apprentice - SHEET METAL WORKER - Local 17-A

Effective Date - 02/01/2019

Step	percent	Apprentice Base Wage	Health	Pension	Supplemental Unemployment	Total Rate
1	42	\$19.53	\$13.20	\$5.89	\$0.00	\$38.62
2	42	\$19.53	\$13.20	\$5.89	\$0.00	\$38.62
3	47	\$21.86	\$13.20	\$11.13	\$1.39	\$47.58
4	47	\$21.86	\$13.20	\$11.13	\$1.39	\$47.58
5	52	\$24.18	\$13.20	\$12.08	\$1.48	\$50.94
6	52	\$24.18	\$13.20	\$12.33	\$1.49	\$51.20
7	60	\$27.90	\$13.20	\$13.70	\$1.64	\$56.44
8	65	\$30.23	\$13.20	\$14.65	\$1.74	\$59.82
9	75	\$34.88	\$13.20	\$16.56	\$1.94	\$66.58
10	85	\$39.53	\$13.20	\$17.96	\$2.12	\$72.81

Effective Date - 08/01/2019

Step	percent	Apprentice Base Wage	Health	Pension	Supplemental Unemployment	Total Rate
1	42	\$20.20	\$13.20	\$5.89	\$0.00	\$39.29
2	42	\$20.20	\$13.20	\$5.89	\$0.00	\$39.29
3	47	\$22.61	\$13.20	\$11.13	\$1.41	\$48.35
4	47	\$22.61	\$13.20	\$11.13	\$1.41	\$48.35
5	52	\$25.01	\$13.20	\$12.08	\$1.51	\$51.80
6	52	\$25.01	\$13.20	\$12.33	\$1.52	\$52.06
7	60	\$28.86	\$13.20	\$13.70	\$1.67	\$57.43
8	65	\$31.27	\$13.20	\$14.65	\$1.77	\$60.89
9	75	\$36.08	\$13.20	\$16.56	\$1.98	\$67.82
10	85	\$40.89	\$13.20	\$17.96	\$2.16	\$74.21

Notes:
Steps are 6 mos.

Apprentice to Journeyworker Ratio:1:4

SPECIALIZED EARTH MOVING EQUIP < 35 TONS TEAMSTERS JOINT COUNCIL NO. 10 ZONE B	12/01/2018	\$33.54	\$11.91	\$12.70	\$0.00	\$58.15
	06/01/2019	\$34.54	\$11.91	\$12.70	\$0.00	\$59.15
	08/01/2019	\$34.54	\$12.41	\$12.70	\$0.00	\$59.65
	12/01/2019	\$34.54	\$12.41	\$13.72	\$0.00	\$60.67
	06/01/2020	\$35.44	\$12.41	\$13.72	\$0.00	\$61.57
	08/01/2020	\$35.44	\$12.91	\$13.72	\$0.00	\$62.07
	12/01/2020	\$35.44	\$12.91	\$14.82	\$0.00	\$63.17
	06/01/2021	\$36.24	\$12.91	\$14.82	\$0.00	\$63.97
	08/01/2021	\$36.24	\$13.41	\$14.82	\$0.00	\$64.47
	12/01/2021	\$36.24	\$13.41	\$16.01	\$0.00	\$65.66

Classification	Effective Date	Base Wage	Health	Pension	Supplemental Unemployment	Total Rate
SPECIALIZED EARTH MOVING EQUIP > 35 TONS <i>TEAMSTERS JOINT COUNCIL NO. 10 ZONE B</i>	12/01/2018	\$33.83	\$11.91	\$12.70	\$0.00	\$58.44
	06/01/2019	\$34.83	\$11.91	\$12.70	\$0.00	\$59.44
	08/01/2019	\$34.83	\$12.41	\$12.70	\$0.00	\$59.94
	12/01/2019	\$34.83	\$12.41	\$13.72	\$0.00	\$60.96
	06/01/2020	\$35.73	\$12.41	\$13.72	\$0.00	\$61.86
	08/01/2020	\$35.73	\$12.91	\$13.72	\$0.00	\$62.36
	12/01/2020	\$35.73	\$12.91	\$14.82	\$0.00	\$63.46
	06/01/2021	\$36.53	\$12.91	\$14.82	\$0.00	\$64.26
	08/01/2021	\$36.53	\$13.41	\$14.82	\$0.00	\$64.76
	12/01/2021	\$36.53	\$13.41	\$16.01	\$0.00	\$65.95
SPRINKLER FITTER <i>SPRINKLER FITTERS LOCAL 550 - (Section B) Zone 2</i>	03/01/2019	\$53.08	\$9.47	\$19.60	\$0.00	\$82.15
	10/01/2019	\$54.43	\$9.47	\$19.60	\$0.00	\$83.50
	03/01/2020	\$55.78	\$9.47	\$19.60	\$0.00	\$84.85
	10/01/2020	\$57.13	\$9.47	\$19.60	\$0.00	\$86.20
	03/01/2021	\$58.48	\$9.47	\$19.60	\$0.00	\$87.55

Apprentice - SPRINKLER FITTER - Local 550 (Section B) Zone 2

Effective Date - 03/01/2019

Step	percent	Apprentice Base Wage	Health	Pension	Supplemental Unemployment	Total Rate
1	35	\$18.58	\$9.47	\$9.10	\$0.00	\$37.15
2	40	\$21.23	\$9.47	\$9.10	\$0.00	\$39.80
3	45	\$23.89	\$9.47	\$9.10	\$0.00	\$42.46
4	50	\$26.54	\$9.47	\$9.10	\$0.00	\$45.11
5	55	\$29.19	\$9.47	\$9.10	\$0.00	\$47.76
6	60	\$31.85	\$9.47	\$10.60	\$0.00	\$51.92
7	65	\$34.50	\$9.47	\$10.60	\$0.00	\$54.57
8	70	\$37.16	\$9.47	\$10.60	\$0.00	\$57.23
9	75	\$39.81	\$9.47	\$10.60	\$0.00	\$59.88
10	80	\$42.46	\$9.47	\$10.60	\$0.00	\$62.53

Effective Date - 10/01/2019

Step	percent	Apprentice Base Wage	Health	Pension	Supplemental Unemployment	Total Rate
1	35	\$19.05	\$9.47	\$9.10	\$0.00	\$37.62
2	40	\$21.77	\$9.47	\$9.10	\$0.00	\$40.34
3	45	\$24.49	\$9.47	\$9.10	\$0.00	\$43.06
4	50	\$27.22	\$9.47	\$9.10	\$0.00	\$45.79
5	55	\$29.94	\$9.47	\$9.10	\$0.00	\$48.51
6	60	\$32.66	\$9.47	\$10.60	\$0.00	\$52.73
7	65	\$35.38	\$9.47	\$10.60	\$0.00	\$55.45
8	70	\$38.10	\$9.47	\$10.60	\$0.00	\$58.17
9	75	\$40.82	\$9.47	\$10.60	\$0.00	\$60.89
10	80	\$43.54	\$9.47	\$10.60	\$0.00	\$63.61

Notes: Apprentice entered prior 9/30/10:
40/45/50/55/60/65/70/75/80/85
Steps are 850 hours

Apprentice to Journeyworker Ratio:1:3

STEAM BOILER OPERATOR	12/01/2018	\$47.10	\$11.50	\$15.60	\$0.00	\$74.20
OPERATING ENGINEERS LOCAL 4	06/01/2019	\$48.19	\$11.50	\$15.60	\$0.00	\$75.29
	12/01/2019	\$49.33	\$11.50	\$15.60	\$0.00	\$76.43
	06/01/2020	\$50.41	\$11.50	\$15.60	\$0.00	\$77.51
	12/01/2020	\$51.55	\$11.50	\$15.60	\$0.00	\$78.65
	06/01/2021	\$52.64	\$11.50	\$15.60	\$0.00	\$79.74
	12/01/2021	\$53.78	\$11.50	\$15.60	\$0.00	\$80.88

For apprentice rates see "Apprentice- OPERATING ENGINEERS"

Classification	Effective Date	Base Wage	Health	Pension	Supplemental Unemployment	Total Rate
TAMPERS, SELF-PROPELLED OR TRACTOR DRAWN <i>OPERATING ENGINEERS LOCAL 4</i>	12/01/2018	\$47.10	\$11.50	\$15.60	\$0.00	\$74.20
	06/01/2019	\$48.19	\$11.50	\$15.60	\$0.00	\$75.29
	12/01/2019	\$49.33	\$11.50	\$15.60	\$0.00	\$76.43
	06/01/2020	\$50.41	\$11.50	\$15.60	\$0.00	\$77.51
	12/01/2020	\$51.55	\$11.50	\$15.60	\$0.00	\$78.65
	06/01/2021	\$52.64	\$11.50	\$15.60	\$0.00	\$79.74
	12/01/2021	\$53.78	\$11.50	\$15.60	\$0.00	\$80.88
For apprentice rates see "Apprentice- OPERATING ENGINEERS"						
TELECOMMUNICATION TECHNICIAN <i>ELECTRICIANS LOCAL 103</i>	03/01/2019	\$38.33	\$13.00	\$16.82	\$0.00	\$68.15

Apprentice - TELECOMMUNICATION TECHNICIAN - Local 103

Effective Date - 03/01/2019

Step	percent	Apprentice Base Wage	Health	Pension	Supplemental Unemployment	Total Rate
1	40	\$15.33	\$13.00	\$0.46	\$0.00	\$28.79
2	40	\$15.33	\$13.00	\$0.46	\$0.00	\$28.79
3	45	\$17.25	\$13.00	\$13.42	\$0.00	\$43.67
4	45	\$17.25	\$13.00	\$13.42	\$0.00	\$43.67
5	50	\$19.17	\$13.00	\$13.73	\$0.00	\$45.90
6	55	\$21.08	\$13.00	\$14.03	\$0.00	\$48.11
7	60	\$23.00	\$13.00	\$14.34	\$0.00	\$50.34
8	65	\$24.91	\$13.00	\$14.66	\$0.00	\$52.57
9	70	\$26.83	\$13.00	\$14.96	\$0.00	\$54.79
10	75	\$28.75	\$13.00	\$15.27	\$0.00	\$57.02

Notes:

Apprentice to Journeyworker Ratio:1:1

TERRAZZO FINISHERS <i>BRICKLAYERS LOCAL 3 - MARBLE & TILE</i>	02/01/2019	\$52.49	\$10.75	\$20.66	\$0.00	\$83.90
	08/01/2019	\$53.84	\$10.75	\$20.80	\$0.00	\$85.39
	02/01/2020	\$54.48	\$10.75	\$20.80	\$0.00	\$86.03
	08/01/2020	\$55.83	\$10.75	\$20.95	\$0.00	\$87.53
	02/01/2021	\$56.47	\$10.75	\$20.95	\$0.00	\$88.17
	08/01/2021	\$57.87	\$10.75	\$21.11	\$0.00	\$89.73
	02/01/2022	\$58.46	\$10.75	\$21.11	\$0.00	\$90.32

Classification

Effective Date Base Wage Health Pension Supplemental Unemployment Total Rate

Apprentice - TERRAZZO FINISHER - Local 3 Marble & Tile

Effective Date - 02/01/2019

Step	percent	Apprentice Base Wage	Health	Pension	Supplemental Unemployment	Total Rate
1	50	\$26.25	\$10.75	\$20.03	\$0.00	\$57.03
2	60	\$31.49	\$10.75	\$20.03	\$0.00	\$62.27
3	70	\$36.74	\$10.75	\$20.03	\$0.00	\$67.52
4	80	\$41.99	\$10.75	\$20.03	\$0.00	\$72.77
5	90	\$47.24	\$10.75	\$20.03	\$0.00	\$78.02

Effective Date - 08/01/2019

Step	percent	Apprentice Base Wage	Health	Pension	Supplemental Unemployment	Total Rate
1	50	\$26.92	\$10.75	\$20.80	\$0.00	\$58.47
2	60	\$32.30	\$10.75	\$20.80	\$0.00	\$63.85
3	70	\$37.69	\$10.75	\$20.80	\$0.00	\$69.24
4	80	\$43.07	\$10.75	\$20.80	\$0.00	\$74.62
5	90	\$48.46	\$10.75	\$20.80	\$0.00	\$80.01

Notes:

Apprentice to Journeyworker Ratio:1:3

TEST BORING DRILLER <i>LABORERS - FOUNDATION AND MARINE</i>	12/01/2018	\$40.00	\$7.85	\$15.55	\$0.00	\$63.40
	06/01/2019	\$41.00	\$7.85	\$15.55	\$0.00	\$64.40
	12/01/2019	\$42.00	\$7.85	\$15.55	\$0.00	\$65.40
	06/01/2020	\$42.99	\$7.85	\$15.55	\$0.00	\$66.39
	12/01/2020	\$43.97	\$7.85	\$15.55	\$0.00	\$67.37
	06/01/2021	\$44.99	\$7.85	\$15.55	\$0.00	\$68.39
	12/01/2021	\$46.00	\$7.85	\$15.55	\$0.00	\$69.40

For apprentice rates see "Apprentice- LABORER"

TEST BORING DRILLER HELPER <i>LABORERS - FOUNDATION AND MARINE</i>	12/01/2018	\$38.72	\$7.85	\$15.55	\$0.00	\$62.12
	06/01/2019	\$39.72	\$7.85	\$15.55	\$0.00	\$63.12
	12/01/2019	\$40.72	\$7.85	\$15.55	\$0.00	\$64.12
	06/01/2020	\$41.71	\$7.85	\$15.55	\$0.00	\$65.11
	12/01/2020	\$42.69	\$7.85	\$15.55	\$0.00	\$66.09
	06/01/2021	\$43.71	\$7.85	\$15.55	\$0.00	\$67.11
	12/01/2021	\$44.72	\$7.85	\$15.55	\$0.00	\$68.12

For apprentice rates see "Apprentice- LABORER"

TEST BORING LABORER <i>LABORERS - FOUNDATION AND MARINE</i>	12/01/2018	\$38.60	\$7.85	\$15.55	\$0.00	\$62.00
	06/01/2019	\$39.60	\$7.85	\$15.55	\$0.00	\$63.00
	12/01/2019	\$40.60	\$7.85	\$15.55	\$0.00	\$64.00
	06/01/2020	\$41.59	\$7.85	\$15.55	\$0.00	\$64.99
	12/01/2020	\$42.57	\$7.85	\$15.55	\$0.00	\$65.97
	06/01/2021	\$43.59	\$7.85	\$15.55	\$0.00	\$66.99
	12/01/2021	\$44.60	\$7.85	\$15.55	\$0.00	\$68.00

For apprentice rates see "Apprentice- LABORER"

Classification	Effective Date	Base Wage	Health	Pension	Supplemental Unemployment	Total Rate
TRACTORS/PORTABLE STEAM GENERATORS <i>OPERATING ENGINEERS LOCAL 4</i>	12/01/2018	\$47.10	\$11.50	\$15.60	\$0.00	\$74.20
	06/01/2019	\$48.19	\$11.50	\$15.60	\$0.00	\$75.29
	12/01/2019	\$49.33	\$11.50	\$15.60	\$0.00	\$76.43
	06/01/2020	\$50.41	\$11.50	\$15.60	\$0.00	\$77.51
	12/01/2020	\$51.55	\$11.50	\$15.60	\$0.00	\$78.65
	06/01/2021	\$52.64	\$11.50	\$15.60	\$0.00	\$79.74
	12/01/2021	\$53.78	\$11.50	\$15.60	\$0.00	\$80.88
For apprentice rates see "Apprentice- OPERATING ENGINEERS"						
TRAILERS FOR EARTH MOVING EQUIPMENT <i>TEAMSTERS JOINT COUNCIL NO. 10 ZONE B</i>	12/01/2018	\$34.12	\$11.91	\$12.70	\$0.00	\$58.73
	06/01/2019	\$35.12	\$11.91	\$12.70	\$0.00	\$59.73
	08/01/2019	\$35.12	\$12.41	\$12.70	\$0.00	\$60.23
	12/01/2019	\$35.12	\$12.41	\$13.72	\$0.00	\$61.25
	06/01/2020	\$36.02	\$12.41	\$13.72	\$0.00	\$62.15
	08/01/2020	\$36.02	\$12.91	\$13.72	\$0.00	\$62.65
	12/01/2020	\$36.02	\$12.91	\$14.82	\$0.00	\$63.75
	06/01/2021	\$36.82	\$12.91	\$14.82	\$0.00	\$64.55
	08/01/2021	\$36.82	\$13.41	\$14.82	\$0.00	\$65.05
	12/01/2021	\$36.82	\$13.41	\$16.01	\$0.00	\$66.24
TUNNEL WORK - COMPRESSED AIR <i>LABORERS (COMPRESSED AIR)</i>	12/01/2018	\$50.88	\$7.85	\$15.95	\$0.00	\$74.68
	06/01/2019	\$51.88	\$7.85	\$15.95	\$0.00	\$75.68
	12/01/2019	\$52.88	\$7.85	\$15.95	\$0.00	\$76.68
	06/01/2020	\$53.87	\$7.85	\$15.95	\$0.00	\$77.67
	12/01/2020	\$54.85	\$7.85	\$15.95	\$0.00	\$78.65
	06/01/2021	\$55.87	\$7.85	\$15.95	\$0.00	\$79.67
	12/01/2021	\$56.88	\$7.85	\$15.95	\$0.00	\$80.68
For apprentice rates see "Apprentice- LABORER"						
TUNNEL WORK - COMPRESSED AIR (HAZ. WASTE) <i>LABORERS (COMPRESSED AIR)</i>	12/01/2018	\$52.88	\$7.85	\$15.95	\$0.00	\$76.68
	06/01/2019	\$53.88	\$7.85	\$15.95	\$0.00	\$77.68
	12/01/2019	\$54.88	\$7.85	\$15.95	\$0.00	\$78.68
	06/01/2020	\$55.87	\$7.85	\$15.95	\$0.00	\$79.67
	12/01/2020	\$56.85	\$7.85	\$15.95	\$0.00	\$80.65
	06/01/2021	\$57.87	\$7.85	\$15.95	\$0.00	\$81.67
	12/01/2021	\$58.88	\$7.85	\$15.95	\$0.00	\$82.68
For apprentice rates see "Apprentice- LABORER"						
TUNNEL WORK - FREE AIR <i>LABORERS (FREE AIR TUNNEL)</i>	12/01/2018	\$42.95	\$7.85	\$15.95	\$0.00	\$66.75
	06/01/2019	\$43.95	\$7.85	\$15.95	\$0.00	\$67.75
	12/01/2019	\$44.95	\$7.85	\$15.95	\$0.00	\$68.75
	06/01/2020	\$45.94	\$7.85	\$15.95	\$0.00	\$69.74
	12/01/2020	\$46.92	\$7.85	\$15.95	\$0.00	\$70.72
	06/01/2021	\$47.94	\$7.85	\$15.95	\$0.00	\$71.74
	12/01/2021	\$48.95	\$7.85	\$15.95	\$0.00	\$72.75
For apprentice rates see "Apprentice- LABORER"						

Classification	Effective Date	Base Wage	Health	Pension	Supplemental Unemployment	Total Rate
TUNNEL WORK - FREE AIR (HAZ. WASTE) <i>LABORERS (FREE AIR TUNNEL)</i>	12/01/2018	\$44.95	\$7.85	\$15.95	\$0.00	\$68.75
	06/01/2019	\$45.95	\$7.85	\$15.95	\$0.00	\$69.75
	12/01/2019	\$46.95	\$7.85	\$15.95	\$0.00	\$70.75
	06/01/2020	\$47.94	\$7.85	\$15.95	\$0.00	\$71.74
	12/01/2020	\$48.92	\$7.85	\$15.95	\$0.00	\$72.72
	06/01/2021	\$49.94	\$7.85	\$15.95	\$0.00	\$73.74
	12/01/2021	\$50.95	\$7.85	\$15.95	\$0.00	\$74.75
For apprentice rates see "Apprentice- LABORER"						
VAC-HAUL <i>TEAMSTERS JOINT COUNCIL NO. 10 ZONE B</i>	12/01/2018	\$33.54	\$11.91	\$12.70	\$0.00	\$58.15
	06/01/2019	\$34.54	\$11.91	\$12.70	\$0.00	\$59.15
	08/01/2019	\$34.54	\$12.41	\$12.70	\$0.00	\$59.65
	12/01/2019	\$34.54	\$12.41	\$13.72	\$0.00	\$60.67
	06/01/2020	\$35.44	\$12.41	\$13.72	\$0.00	\$61.57
	08/01/2020	\$35.44	\$12.91	\$13.72	\$0.00	\$62.07
	12/01/2020	\$35.44	\$12.91	\$14.82	\$0.00	\$63.17
	06/01/2021	\$36.24	\$12.91	\$14.82	\$0.00	\$63.97
	08/01/2021	\$36.24	\$13.41	\$14.82	\$0.00	\$64.47
	12/01/2021	\$36.24	\$13.41	\$16.01	\$0.00	\$65.66
WAGON DRILL OPERATOR <i>LABORERS - ZONE 2</i>	12/01/2018	\$33.77	\$7.85	\$14.44	\$0.00	\$56.06
	06/01/2019	\$34.64	\$7.85	\$14.44	\$0.00	\$56.93
	12/01/2019	\$35.50	\$7.85	\$14.44	\$0.00	\$57.79
	06/01/2020	\$36.39	\$7.85	\$14.44	\$0.00	\$58.68
	12/01/2020	\$37.28	\$7.85	\$14.44	\$0.00	\$59.57
	06/01/2021	\$38.20	\$7.85	\$14.44	\$0.00	\$60.49
	12/01/2021	\$39.11	\$7.85	\$14.44	\$0.00	\$61.40
For apprentice rates see "Apprentice- LABORER"						
WASTE WATER PUMP OPERATOR <i>OPERATING ENGINEERS LOCAL 4</i>	12/01/2018	\$47.58	\$11.50	\$15.60	\$0.00	\$74.68
	06/01/2019	\$48.68	\$11.50	\$15.60	\$0.00	\$75.78
	12/01/2019	\$49.83	\$11.50	\$15.60	\$0.00	\$76.93
	06/01/2020	\$50.93	\$11.50	\$15.60	\$0.00	\$78.03
	12/01/2020	\$52.08	\$11.50	\$15.60	\$0.00	\$79.18
	06/01/2021	\$53.18	\$11.50	\$15.60	\$0.00	\$80.28
	12/01/2021	\$54.33	\$11.50	\$15.60	\$0.00	\$81.43
For apprentice rates see "Apprentice- OPERATING ENGINEERS"						
WATER METER INSTALLER <i>PLUMBERS & GASFITTERS LOCAL 12 (Local 138)</i>	03/01/2019	\$53.11	\$11.82	\$16.01	\$0.00	\$80.94
	09/01/2019	\$54.61	\$11.82	\$16.01	\$0.00	\$82.44
	03/01/2020	\$56.11	\$11.82	\$16.01	\$0.00	\$83.94
	09/01/2020	\$57.61	\$11.82	\$16.01	\$0.00	\$85.44
	03/01/2021	\$59.11	\$11.82	\$16.01	\$0.00	\$86.94
For apprentice rates see "Apprentice- PLUMBER/PIPEFITTER" or "PLUMBER/GASFITTER"						
Outside Electrical - East						
CABLE TECHNICIAN (Power Zone) <i>OUTSIDE ELECTRICAL WORKERS - EAST LOCAL 104</i>	09/03/2017	\$27.14	\$7.75	\$1.81	\$0.00	\$36.70
For apprentice rates see "Apprentice- LINEMAN"						
CABLEMAN (Underground Ducts & Cables) <i>OUTSIDE ELECTRICAL WORKERS - EAST LOCAL 104</i>	09/03/2017	\$38.45	\$7.75	\$9.53	\$0.00	\$55.73
For apprentice rates see "Apprentice- LINEMAN"						

Classification	Effective Date	Base Wage	Health	Pension	Supplemental Unemployment	Total Rate
DRIVER / GROUNDMAN CDL <i>OUTSIDE ELECTRICAL WORKERS - EAST LOCAL 104</i> For apprentice rates see "Apprentice- LINEMAN"	09/03/2017	\$31.66	\$7.75	\$9.44	\$0.00	\$48.85
DRIVER / GROUNDMAN -Inexperienced (<2000 Hrs) <i>OUTSIDE ELECTRICAL WORKERS - EAST LOCAL 104</i> For apprentice rates see "Apprentice- LINEMAN"	09/03/2017	\$24.88	\$7.75	\$1.75	\$0.00	\$34.38
EQUIPMENT OPERATOR (Class A CDL) <i>OUTSIDE ELECTRICAL WORKERS - EAST LOCAL 104</i> For apprentice rates see "Apprentice- LINEMAN"	09/03/2017	\$38.45	\$7.75	\$13.61	\$0.00	\$59.81
EQUIPMENT OPERATOR (Class B CDL) <i>OUTSIDE ELECTRICAL WORKERS - EAST LOCAL 104</i> For apprentice rates see "Apprentice- LINEMAN"	09/03/2017	\$33.92	\$7.75	\$10.21	\$0.00	\$51.88
GROUNDMAN <i>OUTSIDE ELECTRICAL WORKERS - EAST LOCAL 104</i> For apprentice rates see "Apprentice- LINEMAN"	09/03/2017	\$24.88	\$7.75	\$1.75	\$0.00	\$34.38
GROUNDMAN -Inexperienced (<2000 Hrs.) <i>OUTSIDE ELECTRICAL WORKERS - EAST LOCAL 104</i> For apprentice rates see "Apprentice- LINEMAN"	09/03/2017	\$20.35	\$7.75	\$1.61	\$0.00	\$29.71
JOURNEYMAN LINEMAN <i>OUTSIDE ELECTRICAL WORKERS - EAST LOCAL 104</i>	09/03/2017	\$45.23	\$7.75	\$16.61	\$0.00	\$69.59

Apprentice - LINEMAN (Outside Electrical) - East Local 104

Effective Date - 09/03/2017

Step	percent	Apprentice Base Wage	Health	Pension	Supplemental Unemployment	Total Rate
1	60	\$27.14	\$7.75	\$3.31	\$0.00	\$38.20
2	65	\$29.40	\$7.75	\$3.38	\$0.00	\$40.53
3	70	\$31.66	\$7.75	\$3.45	\$0.00	\$42.86
4	75	\$33.92	\$7.75	\$5.02	\$0.00	\$46.69
5	80	\$36.18	\$7.75	\$5.09	\$0.00	\$49.02
6	85	\$38.45	\$7.75	\$5.15	\$0.00	\$51.35
7	90	\$40.71	\$7.75	\$7.22	\$0.00	\$55.68

Notes:

Apprentice to Journeyworker Ratio:1:2

TELEDATA CABLE SPLICER <i>OUTSIDE ELECTRICAL WORKERS - EAST LOCAL 104</i>	02/04/2019	\$30.73	\$4.70	\$3.17	\$0.00	\$38.60
TELEDATA LINEMAN/EQUIPMENT OPERATOR <i>OUTSIDE ELECTRICAL WORKERS - EAST LOCAL 104</i>	02/04/2019	\$28.93	\$4.70	\$3.14	\$0.00	\$36.77
TELEDATA WIREMAN/INSTALLER/TECHNICIAN <i>OUTSIDE ELECTRICAL WORKERS - EAST LOCAL 104</i>	02/04/2019	\$28.93	\$4.70	\$3.14	\$0.00	\$36.77
TREE TRIMMER <i>OUTSIDE ELECTRICAL WORKERS - EAST LOCAL 104</i> This classification applies only to tree work done: (a) for a utility company, R.E.A. cooperative, or railroad or coal mining company, and (b) for the purpose of operating, maintaining, or repairing the utility company's equipment, and (c) by a person who is using hand or mechanical cutting methods and is not on the ground. This classification does not apply to wholesale tree removal.	01/31/2016	\$18.51	\$3.55	\$0.00	\$0.00	\$22.06
TREE TRIMMER GROUNDMAN <i>OUTSIDE ELECTRICAL WORKERS - EAST LOCAL 104</i>	01/31/2016	\$16.32	\$3.55	\$0.00	\$0.00	\$19.87

Classification**Effective Date Base Wage Health Pension Supplemental
Unemployment Total Rate**

This classification applies only to tree work done: (a) for a utility company, R.E.A. cooperative, or railroad or coal mining company, and (b) for the purpose of operating, maintaining, or repairing the utility company's equipment, and (c) by a person who is using hand or mechanical cutting methods and is on the ground. This classification does not apply to wholesale tree removal.

Additional Apprentices Information:

Minimum wage rates for apprentices employed on public works projects are listed above as a percentage of the pre-determined hourly wage rate established by the Commissioner under the provisions of the M.G.L. c. 149, ss. 26-27D. Apprentice ratios are established by the Division of Apprenticeship Training pursuant to M.G.L. c. 23, ss. 11E-11L.

All apprentices must be registered with the Division of Apprenticeship Training in accordance with M.G.L. c. 23, ss. 11E-11L.

All steps are six months (1000 hours.)

Ratios are expressed in allowable number of apprentices to journeymen or fraction thereof, unless otherwise specified.

** Multiple ratios are listed in the comment field.

*** APP to JM; 1:1, 2:2, 2:3, 3:4, 4:4, 4:5, 4:6, 5:7, 6:7, 6:8, 6:9, 7:10, 8:10, 8:11, 8:12, 9:13, 10:13, 10:14, etc.

**** APP to JM; 1:1, 1:2, 2:3, 2:4, 3:5, 4:6, 4:7, 5:8, 6:9, 6:10, 7:11, 8:12, 8:13, 9:14, 10:15, 10:16, etc.

TOWN OF MANCHESTER BY THE SEA PUBLIC WORKS

DOWNTOWN IMPROVEMENT PROJECT (DIP) PHASE II INTERSECTIONS

IN THE TOWN OF
 MANCHESTER BY THE SEA
 ESSEX COUNTY

THE MASSACHUSETTS HIGHWAY DEPARTMENT STANDARD SPECIFICATIONS FOR HIGHWAYS AND BRIDGES DATED 1988, AS AMENDED, THE SUPPLEMENTAL SPECIFICATIONS DATED MARCH 1, 2019, THE OCTOBER 2017 CONSTRUCTION STANDARD DETAILS, THE 2015 OVERHEAD SIGNAL STRUCTURE AND FOUNDATION STANDARD DRAWINGS, MASSDOT TRAFFIC MANAGEMENT PLANS AND DETAIL DRAWINGS, THE LATEST MANUAL ON UNIFORM TRAFFIC CONTROL DEVICES FOR STREETS AND HIGHWAYS WITH MASSACHUSETTS AMENDMENTS, THE 1990 STANDARD DRAWINGS FOR SIGNS AND SUPPORTS, THE 1988 STANDARD DRAWINGS FOR TRAFFIC SIGNALS AND HIGHWAY LIGHTING, AND THE LATEST EDITION OF THE AMERICAN STANDARD FOR NURSERY STOCK, WILL GOVERN.

INDEX

SHEET NO.	DESCRIPTION
01	TITLE SHEET & INDEX
02	LEGEND
03	ABBREVIATIONS & GENERAL NOTES
04	KEY PLAN
05-07	GENERAL PLANS
08-10	ALIGNMENT & GRADING PLANS
11-13	SIGN & PAVEMENT MARKING PLANS
14	SIGN SUMMARY
15-16	TEMPORARY TRAFFIC CONTROL PLANS
17-18	WHEELCHAIR RAMP DETAILS
19-20	CONSTRUCTION DETAILS

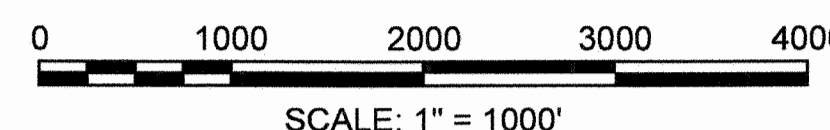
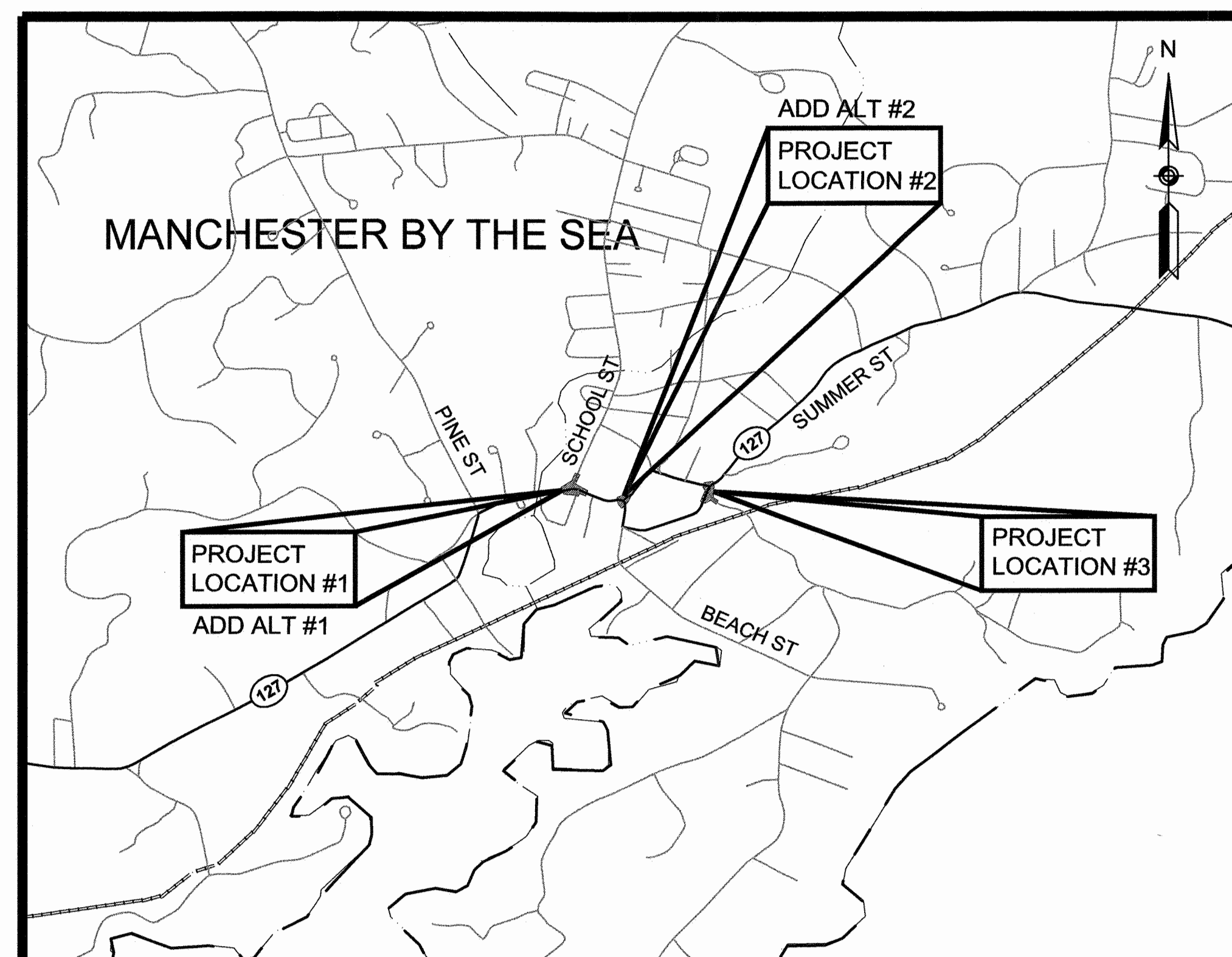

DATE	DESCRIPTION	REV #



 ENGINEER DATE 4/10/19

Vanasse Hangen Brustlin, Inc.
 101 Walnut St., PO Box 9151
 Watertown, MA 02472
 617.924.1770 FAX 617.924.2286

DESIGNED BY JDB	APPROVED BY PGD	SHEET OF 01 20
DRAWN BY JDB	DFTG CHECKED BY JL	VHB CAD FILE NAME 14300 - COV.DWG
CHECKED BY JL	DATE APRIL 18, 2019	JOB NO. 14300.00

GENERAL SYMBOLS

EXISTING	PROPOSED	DESCRIPTION
		JERSEY BARRIER
		CATCH BASIN
		CATCH BASIN CURB INLET
		FLAG POLE
		GAS PUMP
		MAIL BOX
		POST SQUARE
		POST CIRCULAR
		WELL
		ELECTRIC HANDHOLE
		FENCE GATE POST
		GAS GATE
		BORING HOLE
		MONITORING WELL
		TEST PIT
		HYDRANT
		LIGHT POLE
		COUNTY BOUND
		GPS POINT
		CABLE MANHOLE
		DRAINAGE MANHOLE
		ELECTRIC MANHOLE
		GAS MANHOLE
		MISC MANHOLE
		SEWER MANHOLE
		TELEPHONE MANHOLE
		WATER MANHOLE
		MASSACHUSETTS HIGHWAY BOUND
		MONUMENT
		STONE BOUND
		TOWN OR CITY BOUND
		TRAVERSE OR TRIANGULATION STATION
		TROLLEY POLE OR GUY POLE
		TRANSMISSION POLE
		UTILITY POLE W/ FIREBOX
		UTILITY POLE WITH DOUBLE LIGHT
		UTILITY POLE W / 1 LIGHT
		UTILITY POLE
		BUSH
		TREE
		STUMP
		SWAMP / MARSH
		WATER GATE
		PARKING METER
		OVERHEAD CABLE/WIRE
		CURBING
		CONTOURS (ON-THE-GROUND SURVEY DATA)
		CONTOURS (PHOTOGRAMMETRIC DATA)
		UNDERGROUND DRAIN PIPE (DOUBLE LINE 24 INCH AND OVER)
		UNDERGROUND ELECTRIC DUCT (DOUBLE LINE 24 INCH AND OVER)
		UNDERGROUND GAS MAIN (DOUBLE LINE 24 INCH AND OVER)
		UNDERGROUND SEWER MAIN (DOUBLE LINE 24 INCH AND OVER)
		UNDERGROUND TELEPHONE DUCT (DOUBLE LINE 24 INCH AND OVER)
		UNDERGROUND WATER MAIN (DOUBLE LINE 24 INCH AND OVER)
		BALANCED STONE WALL
		GUARD RAIL - STEEL POSTS
		GUARD RAIL - WOOD POSTS
		CHAIN LINK OR METAL FENCE
		WOOD FENCE
		HAY BALES/SILT FENCE
		TREE LINE
		SAWCUT LINE
		TOP OR BOTTOM OF SLOPE
		EDGE OF PAVEMENT
		LIMIT OF MICROMILLING AND OVERLAY
		BANK OF RIVER OR STREAM
		BORDER OF WETLAND
		100 FT WETLAND BUFFER
		200 FT RIVERFRONT BUFFER
		STATE HIGHWAY LAYOUT
		TOWN OR CITY LAYOUT
		COUNTY LAYOUT
		RAILROAD SIDELINE
		TOWN OR CITY BOUNDARY LINE
		PROPERTY LINE OR APPROXIMATE PROPERTY LINE
		EASEMENT

TRAFFIC SYMBOLS

EXISTING	PROPOSED	DESCRIPTION
		CONTROLLER PHASE ACTUATED
		TRAFFIC SIGNAL HEAD (SIZE AS NOTED)
		WIRE LOOP DETECTOR (6' x 6' TYP UNLESS OTHERWISE SPECIFIED)
		VIDEO DETECTION CAMERA
		MICROWAVE DETECTOR
		PEDESTRIAN PUSH BUTTON, SIGN (DIRECTIONAL ARROW AS SHOWN) AND SADDLE
		EMERGENCY PREEMPTION CONFIRMATION STROBE LIGHT
		VEHICULAR SIGNAL HEAD
		VEHICULAR SIGNAL HEAD, OPTICALLY PROGRAMMED
		FLASHING BEACON
		PEDESTRIAN SIGNAL HEAD, (TYPE AS NOTED OR AS SPECIFIED)
		RAILROAD SIGNAL
		SIGNAL POST AND BASE (ALPHA-NUMERIC DESIGNATION NOTED)
		MAST ARM, SHAFT AND BASE (ARM LENGTH AS NOTED)
		HIGH MAST POLE OR TOWER
		SIGN AND POST
		SIGN AND POST (2 POSTS)
		MAST ARM WITH LUMINAIRE
		OPTICAL PRE-EMPTION DETECTOR
		CONTROL CABINET, GROUND MOUNTED
		CONTROL CABINET, POLE MOUNTED
		FLASHING BEACON CONTROL AND METER PEDESTAL
		LOAD CENTER ASSEMBLY
		PULL BOX 12"x12" (OR AS NOTED)
		ELECTRIC HANDHOLE 12"x24" (OR AS NOTED)
		TRAFFIC SIGNAL CONDUIT

PAVEMENT MARKINGS SYMBOLS

EXISTING	PROPOSED	DESCRIPTION
		PAVEMENT ARROW - WHITE
		LEGEND "ONLY" - WHITE
		STOP LINE
		CROSSWALK
		SOLID WHITE LINE
		SOLID YELLOW LINE
		BROKEN WHITE LINE
		BROKEN YELLOW LINE
		DOTTED WHITE LINE
		DOTTED YELLOW LINE
		DOTTED WHITE LINE EXTENSION
		DOTTED YELLOW LINE EXTENSION
		DOUBLE WHITE LINE
		DOUBLE YELLOW LINE

GENERAL ABBREVIATIONS

ABAN	ABANDON
ADJ	ADJUST
APPROX	APPROXIMATE
A.C.	ASPHALT CONCRETE
ACCM PIPE	ASPHALT COATED CORRUGATED METAL PIPE
BIT.	BITUMINOUS
BC	BOTTOM OF CURB
BD.	BOUND
BL	BASELINE
BLDG	BUILDING
BM	BENCHMARK
BO	BY OTHERS
BOS	BOTTOM OF SLOPE
BR.	BRIDGE
CC	CEMENT CONCRETE
CCM	CEMENT CONCRETE MASONRY
CEM	CEMENT
CI	CURB INLET
CLF	CHAIN LINK FENCE
CL	CENTERLINE
CO.	COUNTY
CONC	CONCRETE
CONT	CONTINUOUS / CONTINUED
CONST	CONSTRUCTION
CR GR	CROWN GRADE
DIA	DIAMETER
DWY	DRIVEWAY
ELEV (or EL.)	ELEVATION
EMB	EMBANKMENT
EOP	EDGE OF PAVEMENT
EQ	EQUAL
EXIST (or EX)	EXISTING
EXC	EXCAVATION
FDN.	FOUNDATION
FDP	FULL DEPTH PAVEMENT
FLDSTN	FIELDSTONE
GAR	GARAGE
GD	GROUND
GRAN	GRANITE
GRAV	GRAVEL
GRD	GUARD
HMA	HOT MIX ASPHALT
HOR	HORIZONTAL
HWY	HIGHWAY
JCT	JUNCTION
LOAM	LOAM BORROW
LSA	LANDSCAPED AREA
LT	LEFT
MAHWL	MEAN AVERAGE HIGH WATER LINE
MAX	MAXIMUM
MB	MAILBOX
MHB	MASSACHUSETTS HIGHWAY BOUND
MIN	MINIMUM
MOD	MODIFIED
MSE	MECHANICALLY STABILIZED EARTH
NERR	NEW ENGLAND RAILROAD
NIC	NOT IN CONTRACT
NO.	NUMBER
NTS	NOT TO SCALE
O.C.	ON CENTER
O.D.	OUTSIDE DIAMETER
P.G.L.	PROFILE GRADE LINE
PREV	PREVIOUS/PREVIOUSLY
PROJ	PROJECT
PROP	PROPOSED
PSB	PLANTABLE SOIL BORROW
PVMT	PAVEMENT
R&D	REMOVE AND DISCARD
R&R	REMOVE AND RESET
R&S	REMOVE AND STACK
RD	ROAD
RDWY	ROADWAY
REB	REBUILD
REM	REMOVE
REMOD	REMODEL
RET	RETAIN
RET WALL	RETAINING WALL
ROW	RIGHT OF WAY
RR	RAILROAD
RT	RIGHT
SB	STONE BOUND
SHLD	SHOULDER
SHLO/S.H.L.O.	STATE HIGHWAY LAYOUT LINE

GENERAL ABBREVIATIONS (CONT)

ST	STREET
STA	STATION
STD	STANDARD
SW	SIDEWALK
TEMP	TEMPORARY
TC	TOP OF CURB
TOS	TOP OF SLOPE
TRANS	TRANSITION
TRM	TURF REINFORCING MAT
TYP	TYPICAL
VAR	VARIES
VERT	VERTICAL
WCR	WHEEL CHAIR RAMP
WP	WORKING POINT
X-SECT	CROSS SECTION

UTILITY ABBREVIATIONS

CB	CATCH BASIN
CBCI	CATCH BASIN WITH CURB INLET
CIP	CAST IRON PIPE
CIT	CHANGE IN TYPE
CMCT	COMCAST DUCTBANK
CMP	CORRUGATED METAL PIPE
CSP	CORRUGATED STEEL PIPE
DI	DROP INLET
DIP	DUCTILE IRON PIPE
FES	FLARED END SECTION
F&C	FRAME AND COVER
F&G	FRAME AND GRATE
GG	GAS GATE
GI	GUTTER INLET
GIP	GALVANIZED IRON PIPE
HDPE	HIGH DENSITY POLYETHYLENE PIPE
HDW	HEADWALL
HYD	HYDRANT
INV	INVERT
LB	LEACH BASIN
LP	LIGHT POLE
MH	MANHOLE
MW	MONITORING WELL
OHW	OVERHEAD WIRE
PVC	POLYVINYLCHLORIDE PIPE
PWW	PAVED WATER WAY
RCP	REINFORCED CONCRETE PIPE
SMH	SEWER MANHOLE
TSV&B	TAPPING SLEEVE VALVE & BOX
UP	UTILITY POLE
WG	WATER GATE
WIP	WROUGHT IRON PIPE
WM	WATER METER/WATER MAIN

ALIGNMENT & GRADING ABBREVIATIONS

CC	CENTER OF CURVE
HP	HIGH POINT
I.T.	INTERSECTION OF TANGENT
LP	LOW POINT
PC	POINT OF CURVATURE
PCC	POINT OF COMPOUND CURVATURE
PI	POINT OF INTERSECTION
PNT	POINT
POC	POINT ON CURVE
POT	POINT ON TANGENT
PRC	POINT OF REVERSE CURVATURE
PT	POINT OF TANGENCY
LPT	ANGLE POINT
R	RADIUS OF CURVATURE
T	TANGENT DISTANCE OF CURVE
TAN	TANGENT
25.45	SPOT ELEVATION

PROFILE ABBREVIATIONS

AD	ALGEBRAIC DIFFERENCE IN RATES OF GRADE
HSD	HORIZONTAL SIGHT DISTANCE
K	RATE OF VERTICAL CURVATURE
L	LENGTH OF CURVE
PVC	POINT OF VERTICAL CURVATURE
PVCC	POINT OF VERTICAL COMPOUND CURVATURE
PVI	POINT OF VERTICAL INTERSECTION
PVRC	POINT OF VERTICAL REVERSE CURVATURE
PVT	POINT OF VERTICAL TANGENCY
SSD	STOPPING SIGHT DISTANCE
VC	VERTICAL CURVE

TRAFFIC & SIGNAL ABBREVIATIONS

AADT	ANNUAL AVERAGE DAILY TRAFFIC
CAB.	CABINET
CCVE	CLOSED CIRCUIT VIDEO EQUIPMENT
COND	CONDUIT
CW	CROSS WALK
DW	STEADY DON'T WALK - PORTLAND ORANGE
DHV	DESIGN HOURLY VOLUME
FDW	FLASHING DON'T WALK
FR	FLASHING CIRCULAR RED
FRL	FLASHING RED LEFT ARROW
FRR	FLASHING RED RIGHT ARROW
FY	FLASHING CIRCULAR AMBER
FYL	FLASHING AMBER LEFT ARROW
FYR	FLASHING AMBER RIGHT ARROW
G	STEADY CIRCULAR GREEN
GL	STEADY GREEN LEFT ARROW
GR	STEADY GREEN RIGHT ARROW
GSL	STEADY GREEN SLASH LEFT ARROW
GSR	STEADY GREEN SLASH RIGHT ARROW
GV	STEADY GREEN VERTICAL ARROW
HH	HAND HOLE
OL	OVERLAP
PB	PULL BOX
PED	PEDESTRIAN
PTZ	PAN, TILE, ZOOM
R	STEADY CIRCULAR RED
RL	STEADY RED LEFT ARROW
RR	STEADY RED RIGHT ARROW
SL	STOP LINE
T	TRUCK %
TS OR TR SIG	TRAFFIC SIGNAL
TSC	TRAFFIC SIGNAL CONDUIT
W	STEADY WALK
Y	STEADY CIRCULAR AMBER
YL	STEADY AMBER LEFT ARROW

GENERAL NOTES:

- EXISTING CONDITIONS AND TOPOGRAPHICAL INFORMATION FROM AN ACTUAL FIELD SURVEY CONDUCTED BY DOUCET SURVEY, INC. IN OCTOBER, 2018.
- THE HORIZONTAL CONTROL IS BASED ON THE MASSACHUSETTS MAINLAND STATE PLANE COORDINATE SYSTEM AND THE NATIONAL GEODETIC SURVEY (NAD83). ALL ELEVATION IS US FEET, REFERENCED TO THE NORTH AMERICA VERTICAL DATUM OF 1988 (NAVD88).
- THE CONTRACTOR SHALL VERIFY ALL EXISTING DIMENSIONS AND GRADES IN THE FIELD BEFORE COMMENCING WORK AND PROMPTLY NOTIFY THE ENGINEER OF ANY DISCREPANCIES.
- THE LOCATIONS OF EXISTING UNDERGROUND UTILITIES ARE SHOWN IN AN APPROXIMATE WAY ONLY AND HAVE NOT BEEN INDEPENDENTLY VERIFIED BY THE OWNER OR ITS REPRESENTATIVE. THE CONTRACTOR SHALL DETERMINE THE EXACT LOCATION OF ALL EXISTING UTILITIES BEFORE COMMENCING WORK, AND SHALL BE FULLY RESPONSIBLE FOR ANY AND ALL DAMAGES WHICH MIGHT BE OCCASIONED BY THE CONTRACTOR'S FAILURE TO EXACTLY LOCATE AND PRESERVE ANY AND ALL UNDERGROUND UTILITIES.
- DRAINAGE ELEVATIONS ARE PROVIDED FOR DESIGN PURPOSES ONLY. THE CONTRACTOR SHALL VERIFY BY TEST PIT, THE LOCATIONS OF EXISTING UTILITIES WHICH MAY CONFLICT WITH THE PROPOSED DRAINAGE DESIGN. ANY FIELD ADJUSTMENTS REQUIRED WILL BE MADE AS APPROVED OR DIRECTED BY THE ENGINEER. ONLY AFTER THE CONTRACTOR VERIFIES ELEVATIONS FOR THE CONSTRUCTABILITY OF THE DRAINAGE SYSTEM SHALL ANY STRUCTURES BE ORDERED. ANY FIELD ADJUSTMENTS TO LINE & GRADE UP TO A DEPTH OF 5' SHALL BE INCLUDED IN THE COST OF THE PIPE. PIPE EXCAVATION GREATER THAN 5' WILL BE PAID UNDER CLASS B TRENCH EXCAVATION.
- WHERE AN EXISTING UTILITY IS FOUND TO CONFLICT WITH THE PROPOSED WORK, THE LOCATION, ELEVATION AND SIZE OF THE UTILITY SHALL BE ACCURATELY DETERMINED WITHOUT DELAY BY THE CONTRACTOR, AND THE INFORMATION FURNISHED TO THE ENGINEER FOR RESOLUTION OF THE CONFLICT.
- THE CONTRACTOR SHALL ALTER THE MASONRY OF THE TOP SECTION OF ALL EXISTING DRAINAGE AND SEWER STRUCTURES AS NECESSARY FOR CHANGES IN GRADE, AND RESET ALL WATER AND DRAINAGE FRAMES, GRATES AND BOXES TO THE PROPOSED FINISH SURFACE GRADE. REQUIRED NEW MASONRY SHALL BE CLAY BRICK.
- THE CONTRACTOR SHALL MAKE ALL ARRANGEMENTS FOR THE ALTERATION AND ADJUSTMENT OF GAS, ELECTRIC, TELEPHONE AND ANY OTHER PRIVATE UTILITIES BY THE UTILITY COMPANIES.
- TREES AND SHRUBS WITHIN THE LIMITS OF GRADING SHALL BE REMOVED ONLY UPON APPROVAL OF THE ENGINEER.
- AREAS OUTSIDE THE LIMITS OF PROPOSED WORK DISTURBED BY THE CONTRACTOR'S OPERATIONS SHALL BE RESTORED BY THE CONTRACTOR TO THEIR ORIGINAL CONDITION AT NO EXPENSE TO THE OWNER.
- THE TERM "PROPOSED" (PROP) MEANS WORK TO BE CONSTRUCTED USING NEW MATERIALS OR, WHERE APPLICABLE, RE-USING EXISTING MATERIALS IDENTIFIED AS "REMOVE AND RESET" (R&R).
- JOINTS BETWEEN NEW ASPHALT CONCRETE ROADWAY PAVEMENT AND SAWCUT EXISTING PAVEMENT SHALL BE SEALED WITH HMA JOINT SEALER AND BACKSANDS.
- EXISTING SIGNS WITHIN THE PROJECT LIMITS SHALL BE RETAINED UNLESS INDICATED OTHERWISE ON THE DRAWINGS.
- IF SUITABLE, EXISTING GRANITE CURB SHALL BE RE-USED IN THE PROPOSED WORK, EXCEPT CURVED STONES OF A DIFFERENT RADIUS THAN PROPOSED CURB.
- PROPOSED BOUNDS SHALL BE PLACED BY A LICENSED PROFESSIONAL SURVEYOR. THE CONTRACTOR SHALL EXERCISE DUE CARE WHEN WORKING AROUND ALL PROPERTY BOUNDS WHICH ARE TO REMAIN. SHOULD ANY DAMAGE TO A BOUND RESULT FROM THE ACTIONS OF THE CONTRACTOR, THE CONTRACTOR SHALL HAVE THE BOUND REPLACED AND/OR REALIGNED BY A LICENSED PROFESSIONAL SURVEYOR AS DIRECTED BY THE ENGINEER AT NO ADDITIONAL COST.
- DISPOSAL OF ALL SURPLUS MATERIAL SHALL BE AS APPROVED BY THE ENGINEER AND OWNER.
- LATERAL DRAIN PIPES SHALL BE INSTALLED WITH A PITCH OF 0.01 FOOT PER FOOT (MINIMUM) UNLESS NOTED OTHERWISE ON THE PLANS.
- THE CONTRACTOR SHALL COORDINATE THE RELOCATION OF ALL ABUTTER-OWNED STREET FURNISHINGS WITHIN THE LIMITS OF WORK.

PAVEMENT NOTES

PROPOSED PAVEMENT MICROMILLING AND OVERLAY

SURFACE: 1 1/2" SUPERPAVE SURFACE COURSE - 9.5 (SSC-9.5)

MILLING: 1 1/2" PAVEMENT MICROMILLING

PROPOSED HOT MIX ASPHALT WALK

SURFACE: 3" SUPERPAVE SURFACE COURSE - 9.5 (SSC-9.5)
(2 EQUAL LIFTS OF 1 1/2" EACH)

SUBBASE: 8" GRAVEL BORROW, TYPE B

PROPOSED HOT MIX ASPHALT DRIVEWAY

SURFACE: 1 1/2" SUPERPAVE SURFACE COURSE - 9.5 (SSC-9.5)

INTERMEDIATE: 2" SUPERPAVE INTERMEDIATE COURSE - 12.5 (SIC-12.5)

SUBBASE: 8" GRAVEL BORROW, TYPE B

PROPOSED CEMENT CONCRETE WHEELCHAIR RAMP

SURFACE: 4" CEMENT CONCRETE
AIR ENTRAINED 4000 PSI, 3/4", 610

SUBBASE: 8" GRAVEL BORROW, TYPE b

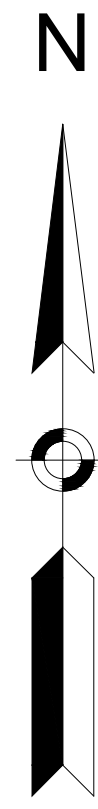

LEGEND

- ⊙## GENERAL PLANS
- ## ALIGNMENT & GRADING PLANS
- △## SIGN & PAVEMENT MARKING PLANS

PROJECT LOCATION #1
 (ADD ALTERNATE #1)

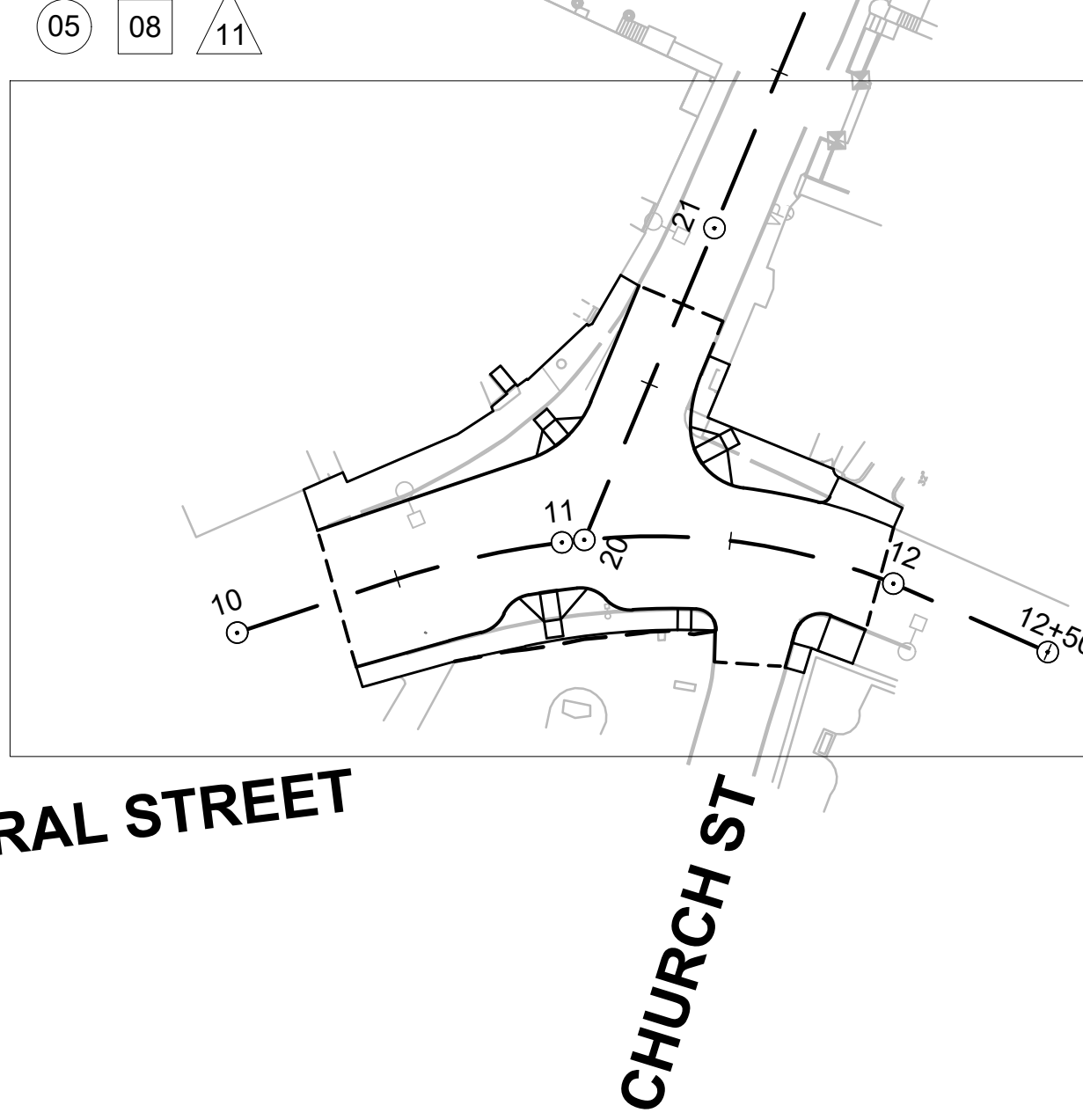

PROJECT LOCATION #2
 (ADD ALTERNATE #2)

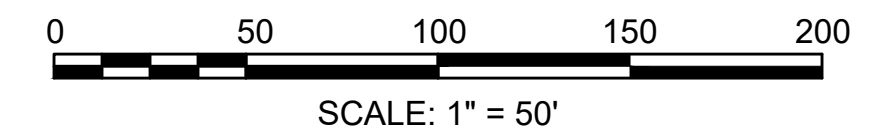
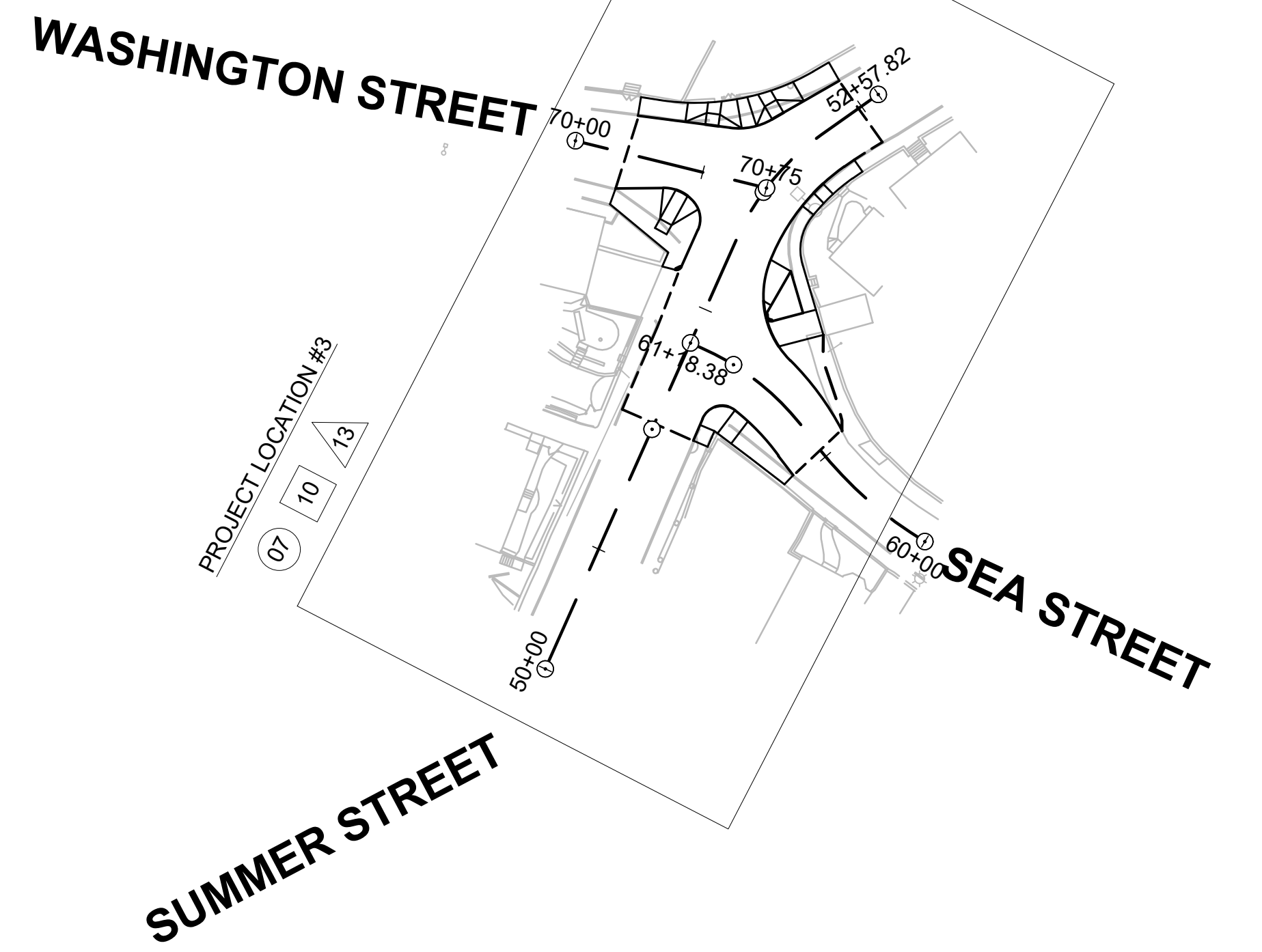
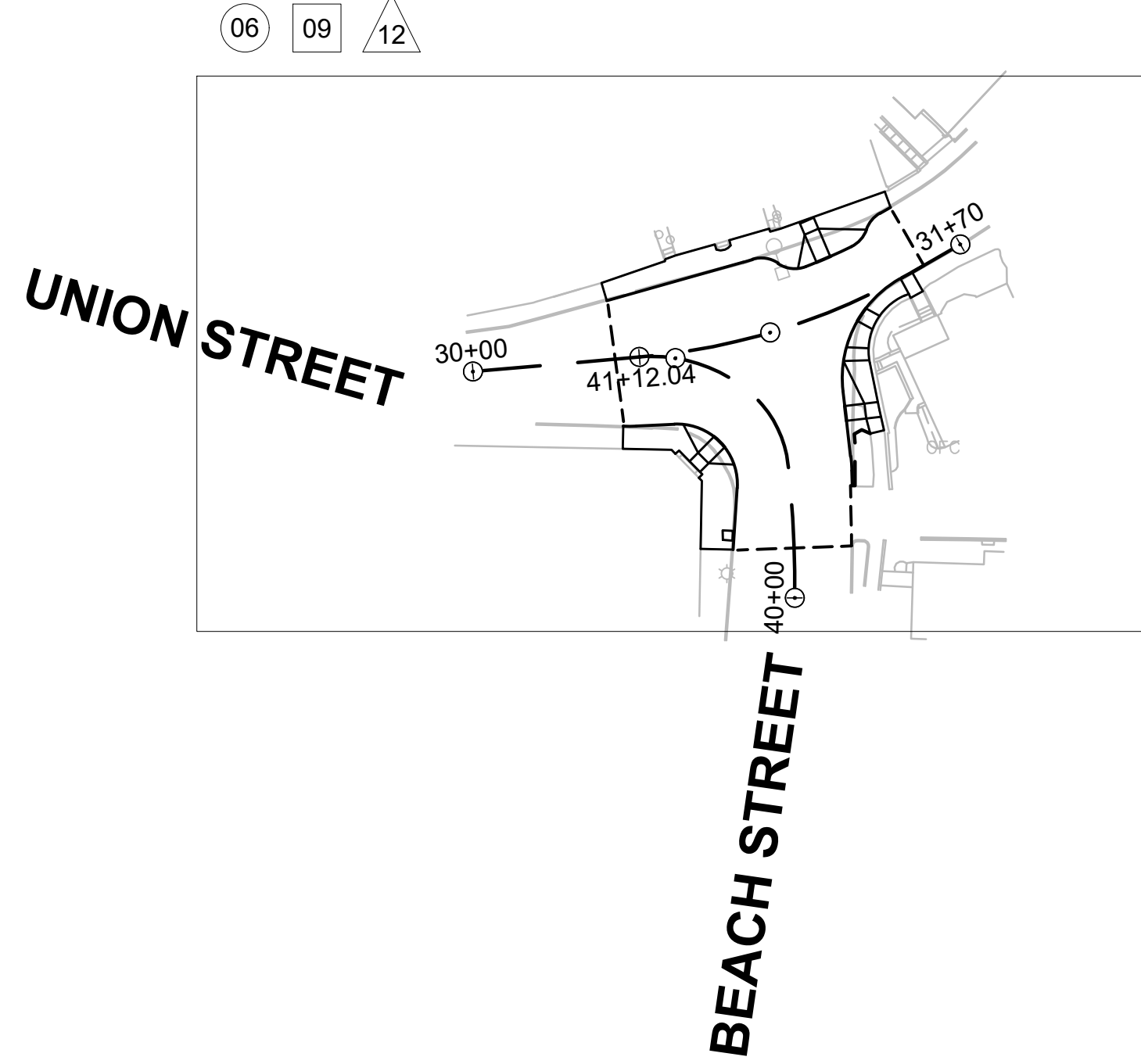

ADD ALTERNATIVE #1

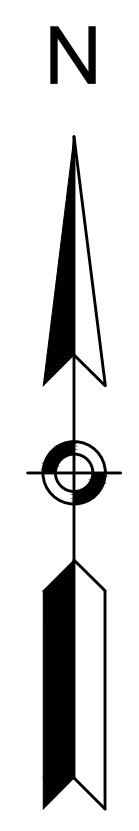

DRAINAGE STRUCTURE TABLE							
NAME	TYPE	STATION	OFFSET	RIM ELEV.	INV. ELEV. IN	INV. ELEV. OUT	REMARKS
17	GICI	20+42.11	13.0 L	13.44		I=11.08' (1929)	GUTTER INLET SPECIAL
1914	EX CB	20+44.24	15.6 R	13.69	I=11.20' (2072)	I=10.69' (1930)	STRUCTURE REPLACED BY OTHERS ADJ F&G
1929	EX CB	20+42.11	20.4 L	13.38	I=11.00' (17)	I=11.00' (1930)	ADJ, PROP F&C
1930	EX DMH	20+45.41	26.3 L	13.39	I=9.70' (1914) I=10.50' (1929)		ADJ

NOTES:

- SEE SHEET 11 FOR DISPOSITION OF ALL SIGNS AND PAVEMENT MARKINGS WITHIN THE LIMIT OF WORK.
- SEE PAVEMENT NOTES, SHEET 03

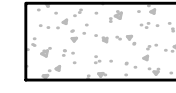
 CEMENT CONCRETE WHEELCHAIR RAMP

EXISTING DRAINAGE STRUCTURE DATA (DSI SURVEY, OCT 2018)

DMH 1914
RIM ELEV.=14.3'
(A) HOLE CUT IN CONC CURB TO SCUPPER
INV.=13.1'
(2072) UNKN INV.=11.2' (10" PIPE**)
(B) POSSIBLE INV. VERY RECESSED
(10" PIPE GOING TO DMH 1930**)

CB 1929
RIM ELEV.=12.9'
(1930) 10" CLAY INV.=11'

DMH 1930
RIM ELEV.=13.4'
(1929) 10" CLAY INV.=10.5'
(A) 10" PVC INV.=9.7' (FROM 1914**)
(B) 6" UNKN INV.=8.9'
[ELBOW TOWARDS BLD] TOP OF ELBOW=6.2'

CBD 2072
RIM ELEV.=13.7'
(1914) 8" HDPE INV.=12.1' (10" PIPE**)

MH 2254
RIM ELEV.=7.6'

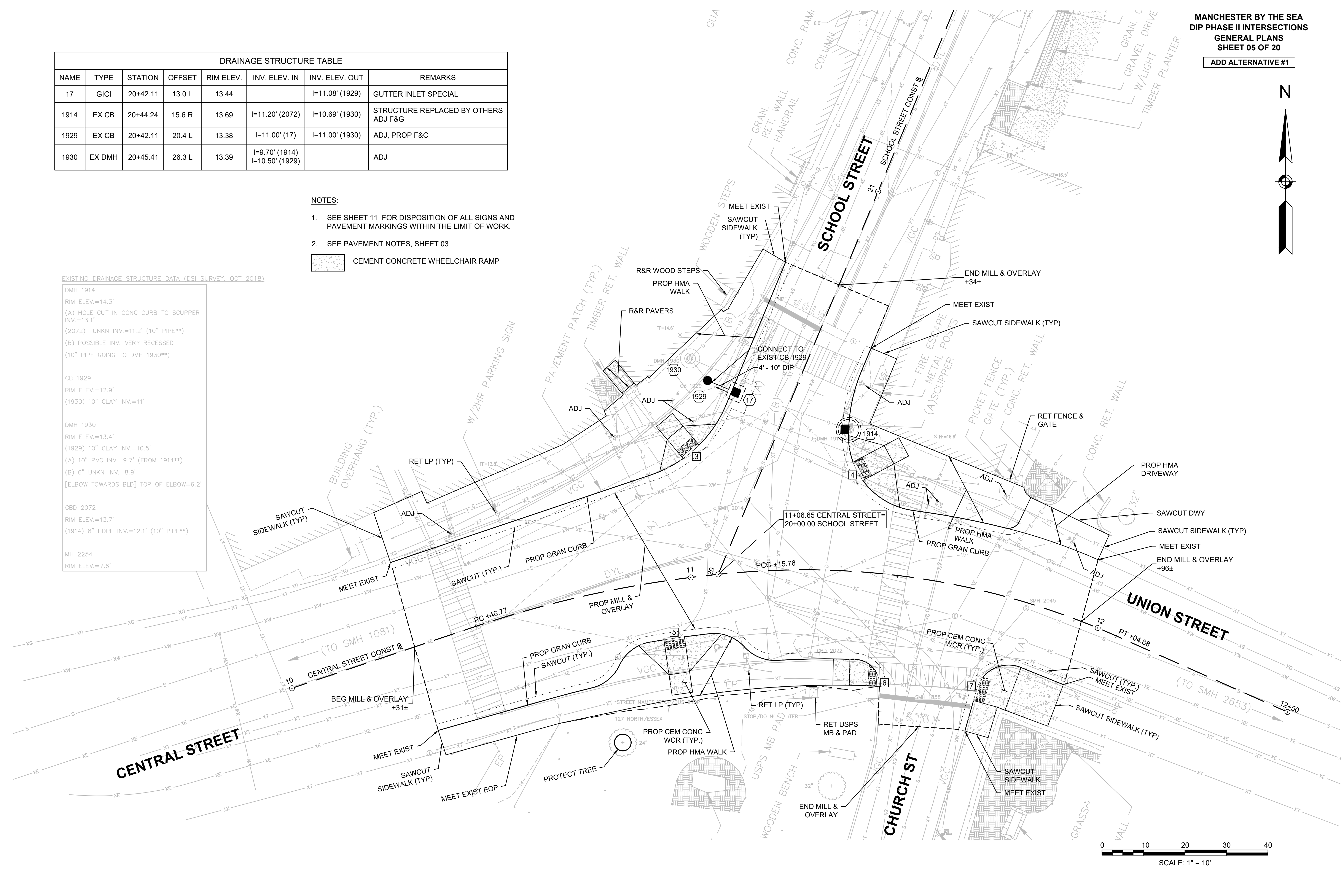

ADD ALTERNATIVE #2





NOTES:

1. SEE SHEET 12 FOR DISPOSITION OF ALL SIGNS AND PAVEMENT MARKINGS WITHIN THE LIMIT OF WORK.
2. SEE PAVEMENT NOTES, SHEET 03.
3. VARIABLE DEPTH OVERLAY STA 31+00 TO 31+50. SEE GRADING SHEET 09.

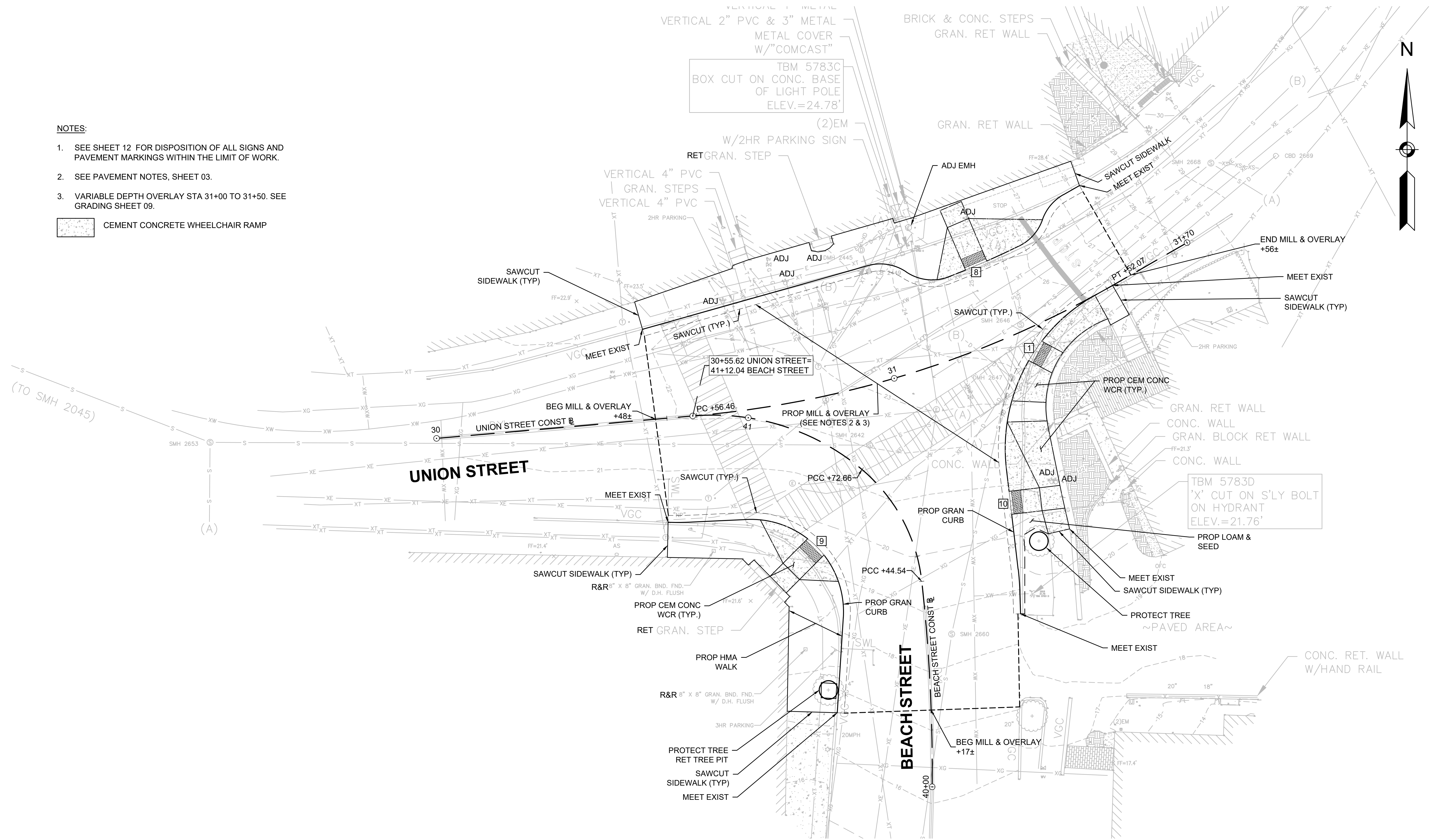
 CEMENT CONCRETE WHEELCHAIR RAMP

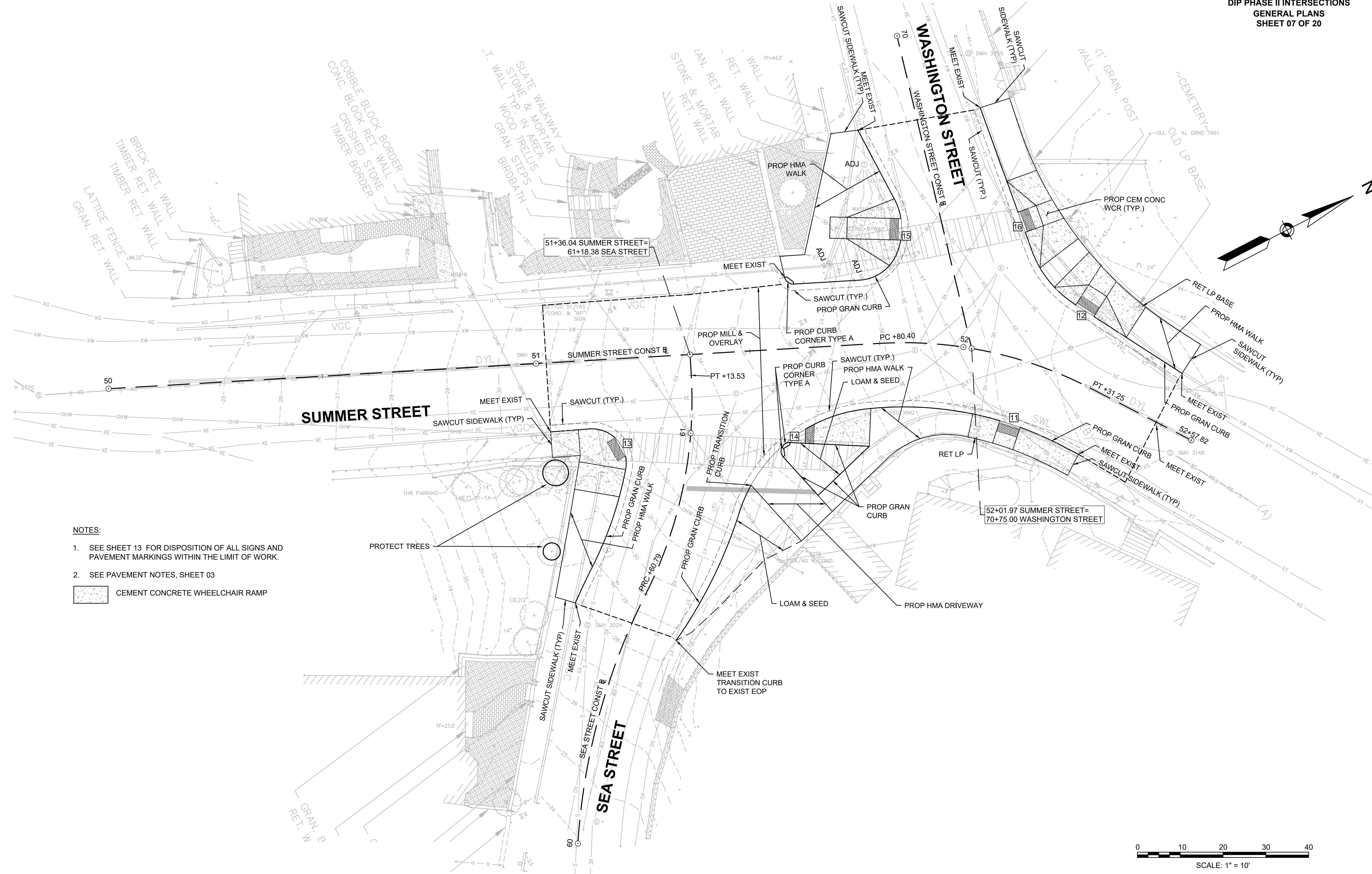



- NOTES:**
- SEE SHEET 13 FOR DISPOSITION OF ALL SIGNS AND PAVEMENT MARKINGS WITHIN THE LIMIT OF WORK.
 - SEE PAVEMENT NOTES, SHEET 03
-  CEMENT CONCRETE WHEELCHAIR RAMP



ADD ALTERNATIVE #1

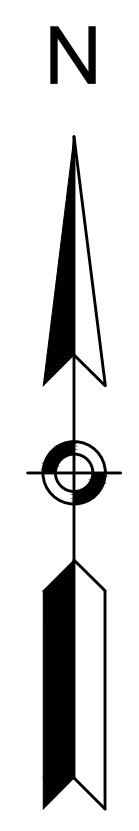

NUMBER	STARTING STATION	NORTHING	EASTING	CURVE DATA	LINE DATA	ENDING STATION	NORTHING	EASTING
L1	10+00.00	3035504.4843	852213.1470		N71°23'53"E 46.77'	10+46.77	3035519.4041	852257.4757
C1	10+46.77	3035519.4041	852257.4757	R=264.00' Δ=14°58'17" L=68.98' T=34.69'		11+15.76	3035532.6663	852324.9728
C2	11+15.76	3035532.6663	852324.9728	R=185.00' Δ=27°36'10" L=89.13' T=45.44'		12+04.88	3035517.0798	852411.8514
L2	12+04.88	3035517.0798	852411.8514		S66°01'40"E 45.12'	12+50.00	3035498.7482	852453.0785

NUMBER	STARTING STATION	NORTHING	EASTING	CURVE DATA	LINE DATA	ENDING STATION	NORTHING	EASTING
L3	20+00.00	3035531.9329	852315.8949		N22°39'24"E 200.00'	22+00.00	3035716.4989	852392.9364

CURVE #	RADIUS	LENGTH	TANGENT	DELTA
1	242.00	9.71	4.857	2°17'59"
2	10.00	8.95	4.801	51°17'19"
3	10.00	9.60	5.208	55°01'01"
4	30.00	25.52	13.590	48°44'29"
5	10.00	9.43	5.096	54°00'30"
6	8.00	13.44	8.923	96°14'32"
7	40.00	16.26	8.245	23°17'40"
8	18.00	25.72	15.607	81°51'17"
9	201.00	22.54	11.280	6°25'27"
10	3.00	4.10	2.445	78°21'18"
12	10.00	8.94	4.793	51°13'13"
13	180.00	18.75	9.385	5°58'10"
14	6.00	9.27	5.847	88°30'57"

LEGEND:
 WHEELCHAIR RAMP NUMBER
 CURVE NUMBER

Point #	Northing	Easting	Elevation	Description
5	3035517.233	852135.904	12.621	MAG SET
8	3035510.391	852340.416	14.726	MAG SET
213	3035434.028	852220.022	13.648	MAG SET

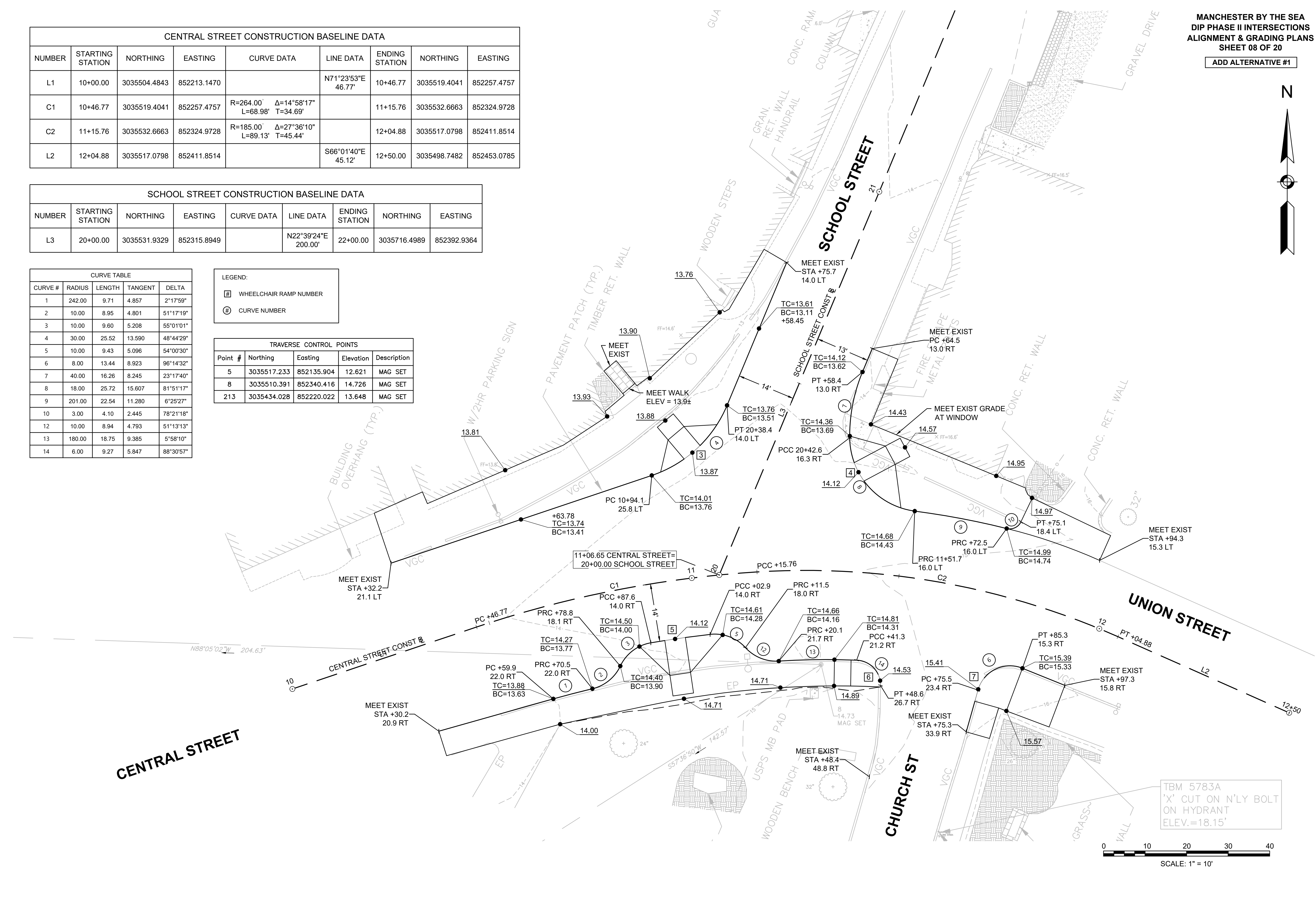

TBM 5783A
'X' CUT ON N'LY BOLT
ON HYDRANT
ELEV.=18.15'



ADD ALTERNATIVE #2

NUMBER	STARTING STATION	NORTHING	EASTING	CURVE DATA	LINE DATA	ENDING STATION	NORTHING	EASTING
L4	30+00.00	3035434.6470	852671.5095		N84°59'14"E 56.46'	30+56.46	3035439.5801	852727.7520
C3	30+56.46	3035439.5801	852727.7520	R=220.00' Δ=24°54'02" L=95.61' T=48.57'		31+52.07	3035468.0469	852818.2409
L5	31+52.07	3035468.0469	852818.2409		N60°05'12"E 17.93'	31+70.00	3035476.9884	852833.7822

NUMBER	STARTING STATION	NORTHING	EASTING	CURVE DATA	LINE DATA	ENDING STATION	NORTHING	EASTING
C4	40+00.00	3035359.2718	852778.6757	R=370.00' Δ=6°53'48" L=44.54' T=22.29'		40+44.54	3035403.7244	852776.4313
C5	40+44.54	3035403.7244	852776.4313	R=37.00' Δ=43°32'45" L=28.12' T=14.78'		40+72.66	3035427.9350	852763.4978
C6	40+72.66	3035427.9350	852763.4978	R=50.00' Δ=45°07'43" L=39.38' T=20.78'		41+12.04	3035439.5065	852726.9122

Point #	Northing	Easting	Elevation	Description
9	3035454.771	852598.835	20.018	MAG SET
100	3035423.289	852749.941	20.711	MAG SET
101	3035480.040	852842.300	28.982	MAG SET

LEGEND:

☐ WHEELCHAIR RAMP NUMBER

⊙ CURVE NUMBER

CURVE #	RADIUS	LENGTH	TANGENT	DELTA
20	50.00	4.36	2.180	4°59'35"
21	20.00	33.62	22.330	96°18'05"
23	10.00	8.88	4.755	50°51'35"
24	10.00	9.68	5.258	55°28'12"
25	10.00	7.81	4.117	44°45'20"
26	10.00	7.20	3.762	41°14'14"
28	38.00	44.38	25.108	66°54'32"
29	19.88	27.21	16.221	78°25'50"

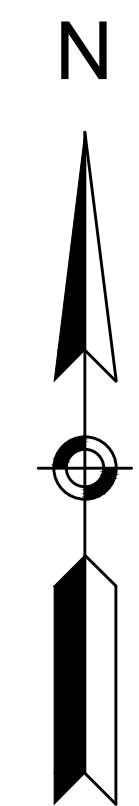
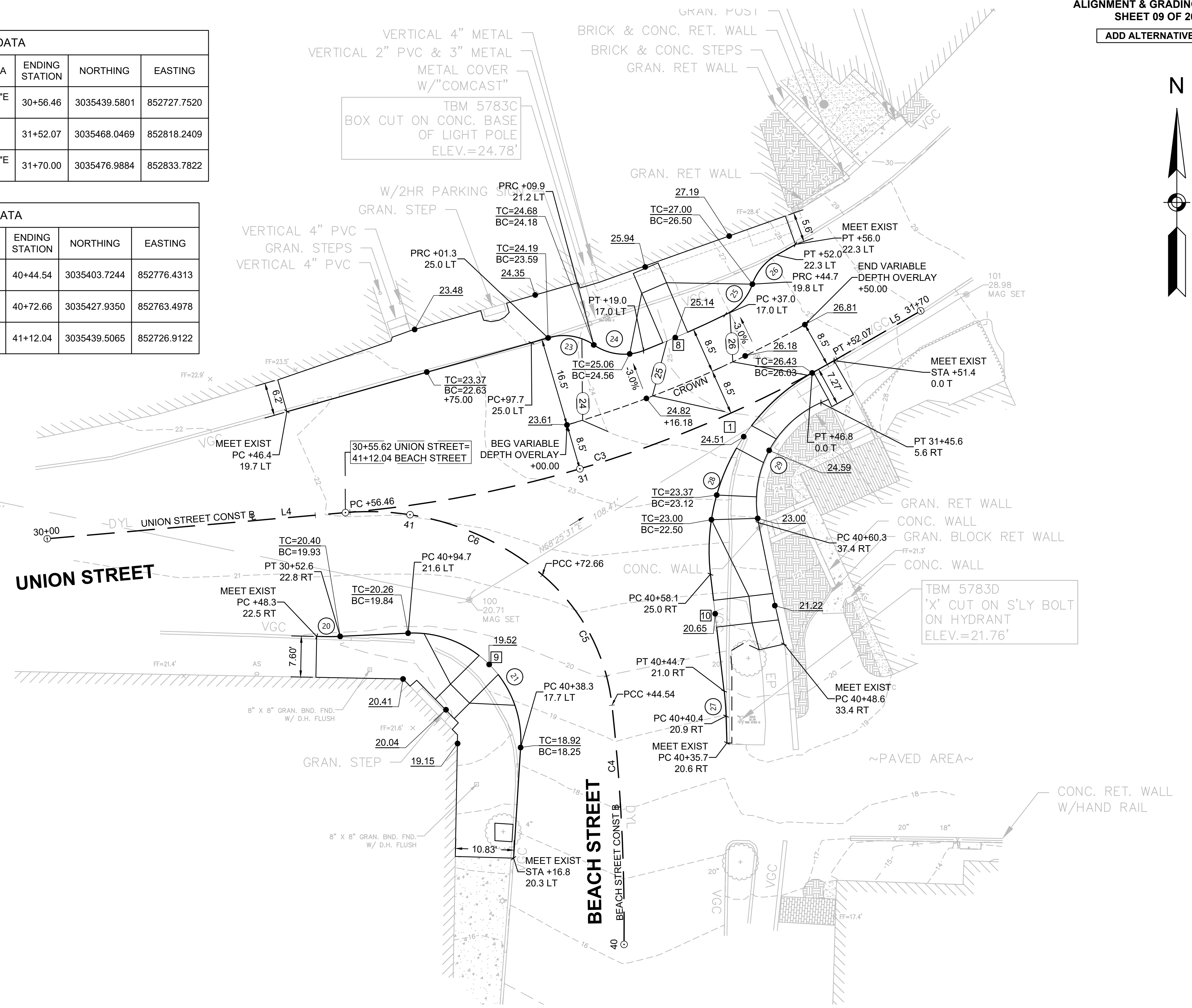

SUMMER STREET CONSTRUCTION BASELINE DATA								
NUMBER	STARTING STATION	NORTHING	EASTING	CURVE DATA	LINE DATA	ENDING STATION	NORTHING	EASTING
L6	50+00.00	3035370.8023	853423.6318		N23°59'48"E 180.40'	51+80.40	3035535.6126	853496.9989
C7	51+80.40	3035535.6126	853496.9989	R=95.00' Δ=30°40'06" L=50.85' T=26.05'		52+31.25	3035574.4771	853528.8441
L7	52+31.25	3035574.4771	853528.8441		N54°39'54"E 26.57'	52+57.82	3035589.8450	853550.5209

CURVE TABLE				
CURVE #	RADIUS	LENGTH	TANGENT	DELTA
40	8.00	14.68	10.451	105°08'07"
41	110.00	33.38	16.817	17°23'03"
42	35.00	40.30	22.720	65°58'40"
43	80.00	47.07	24.237	33°42'36"
45	10.00	11.03	6.154	63°13'07"
46	15.00	13.43	7.201	51°17'09"
47	25.00	16.27	8.435	37°17'19"

TRAVERSE CONTROL POINTS				
Point #	Northing	Easting	Elevation	Description
11	3035337.714	853419.862	21.593	MAG SET
54	3035553.361	853479.567	39.328	MAG SET
102	3035465.414	853487.692	31.273	MAG SET

LEGEND:	
	WHEELCHAIR RAMP NUMBER
	CURVE NUMBER

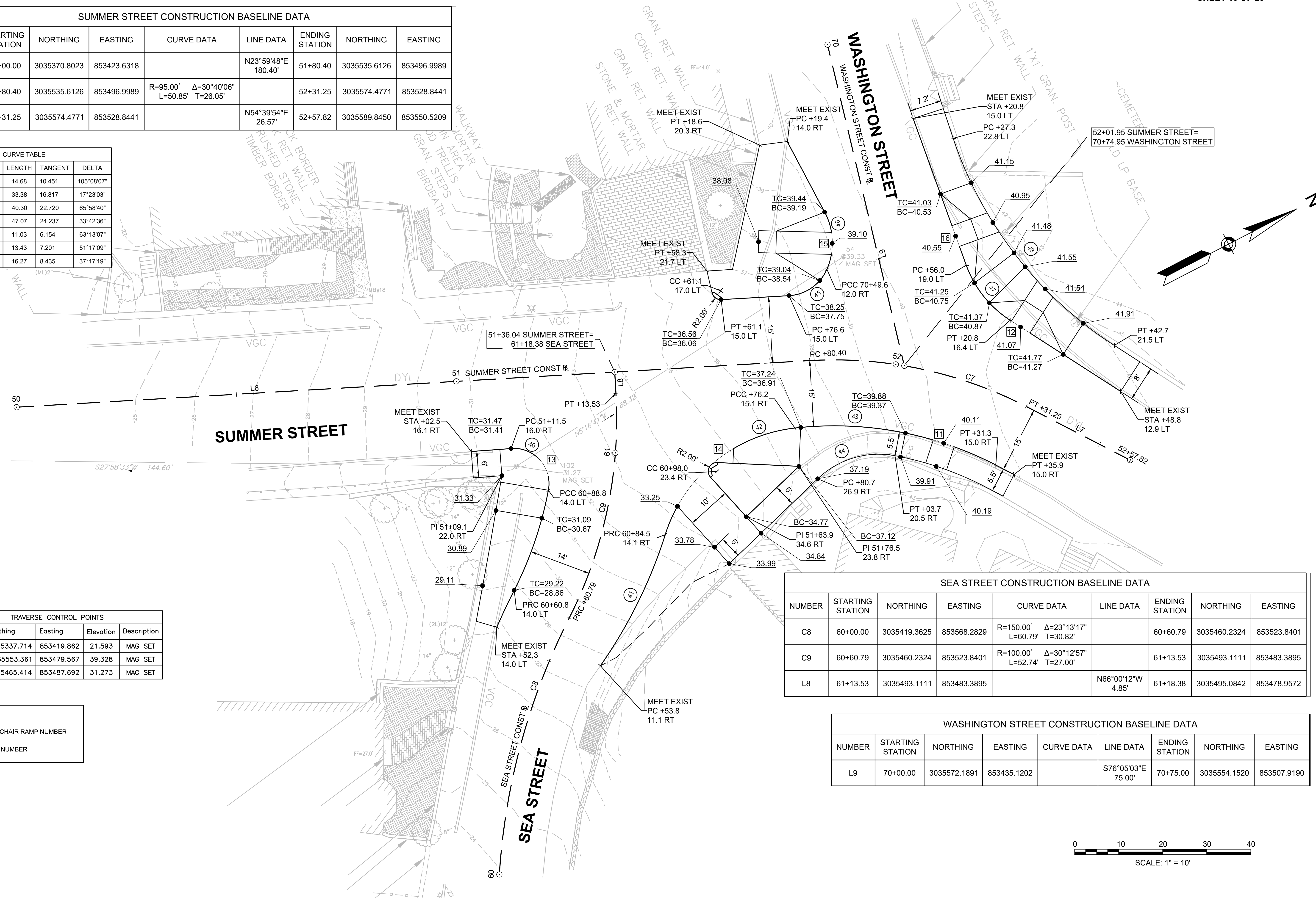

SEA STREET CONSTRUCTION BASELINE DATA								
NUMBER	STARTING STATION	NORTHING	EASTING	CURVE DATA	LINE DATA	ENDING STATION	NORTHING	EASTING
C8	60+00.00	3035419.3625	853568.2829	R=150.00' Δ=23°13'17" L=60.79' T=30.82'		60+60.79	3035460.2324	853523.8401
C9	60+60.79	3035460.2324	853523.8401	R=100.00' Δ=30°12'57" L=52.74' T=27.00'		61+13.53	3035493.1111	853483.3895
L8	61+13.53	3035493.1111	853483.3895		N66°00'12"W 4.85'	61+18.38	3035495.0842	853478.9572

WASHINGTON STREET CONSTRUCTION BASELINE DATA								
NUMBER	STARTING STATION	NORTHING	EASTING	CURVE DATA	LINE DATA	ENDING STATION	NORTHING	EASTING
L9	70+00.00	3035572.1891	853435.1202		S76°05'03"E 75.00'	70+75.00	3035554.1520	853507.9190

ADD ALTERNATIVE #1

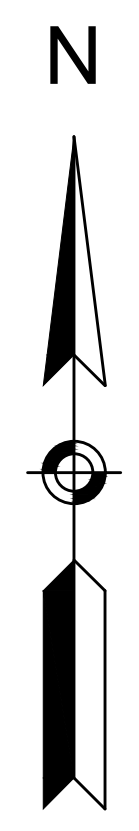

CENTRAL STREET

SCHOOL STREET

UNION STREET



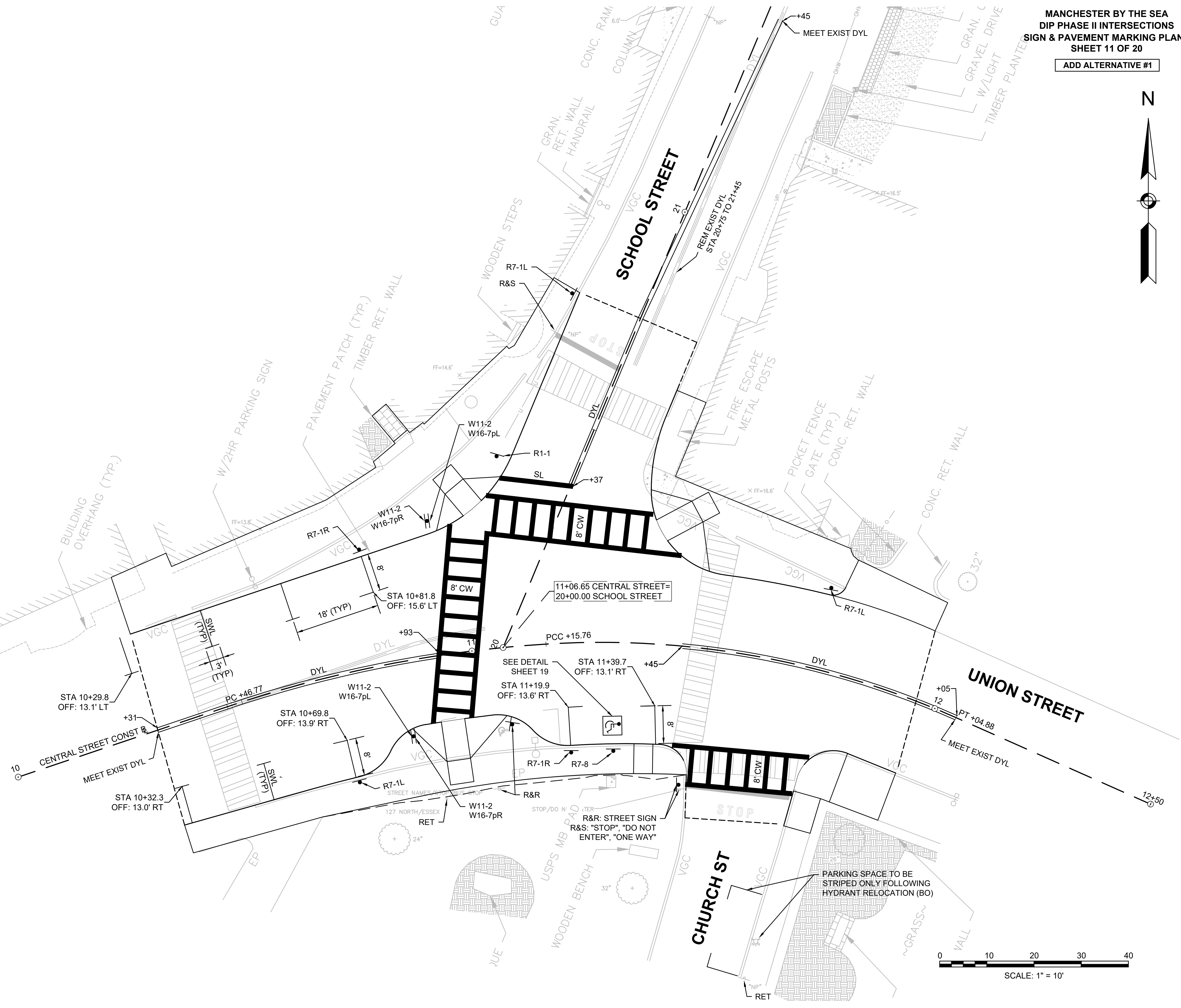

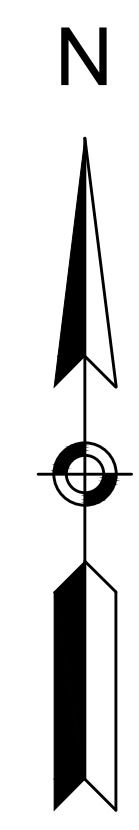
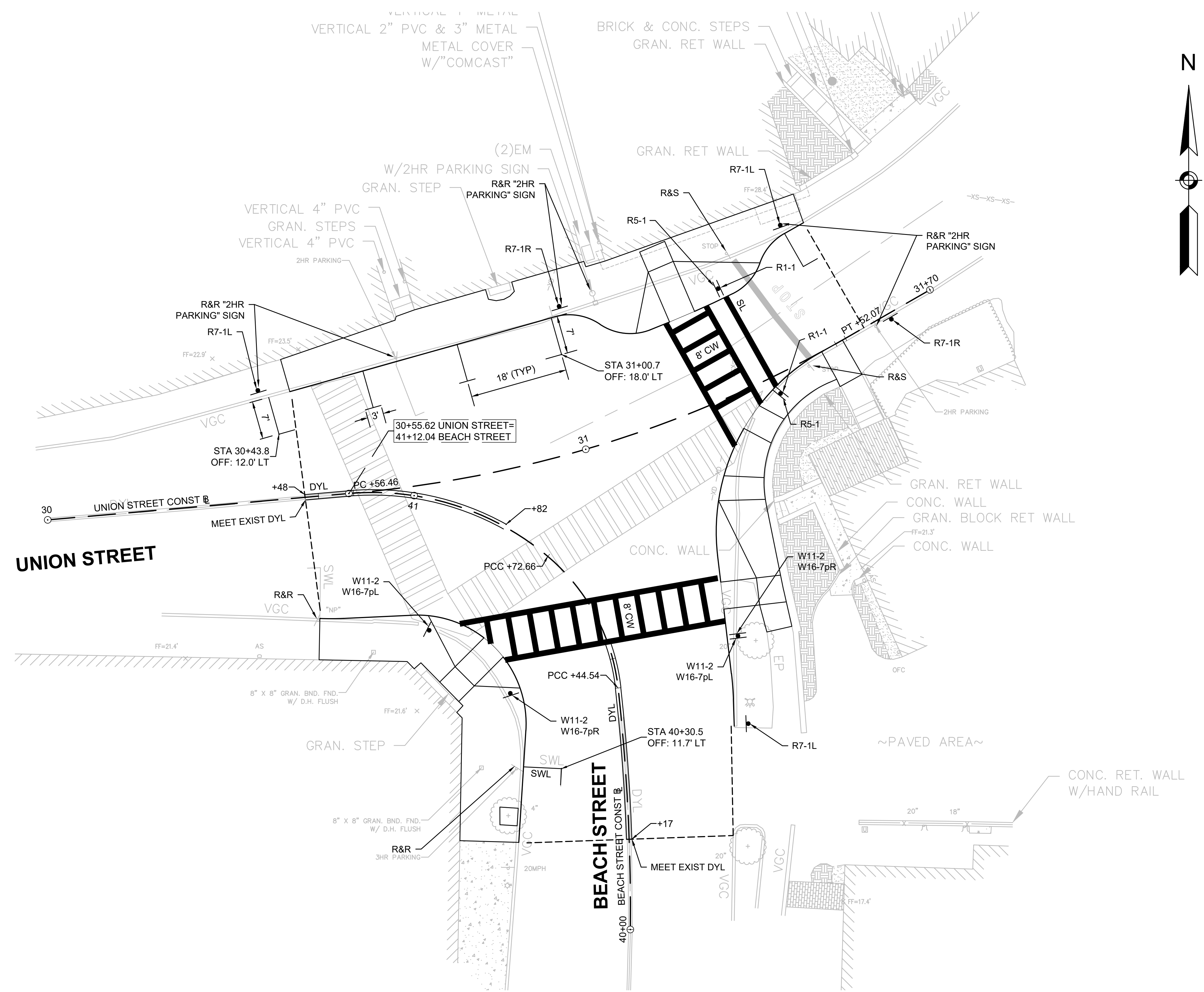

CHURCH ST

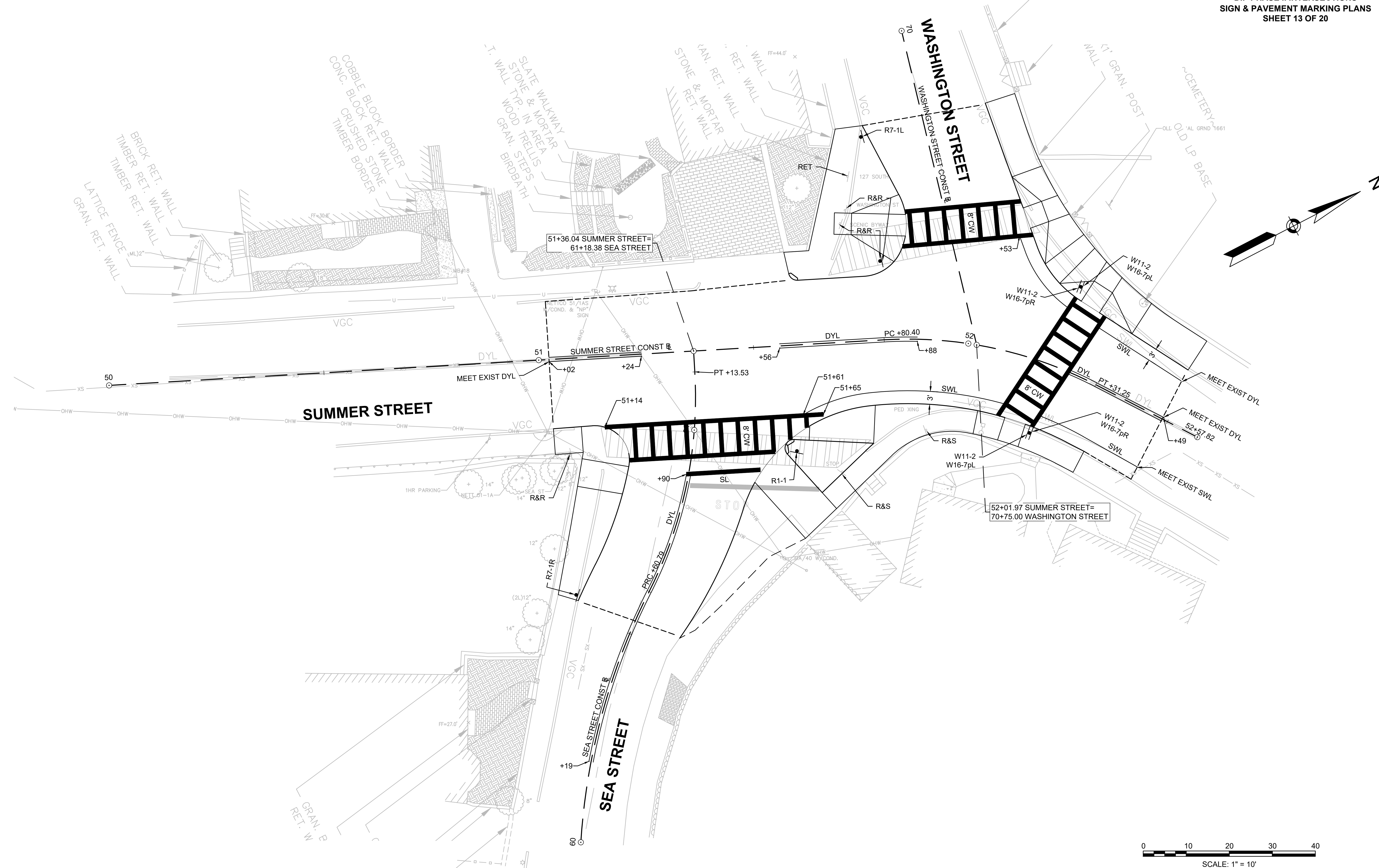

ADD ALTERNATIVE #2



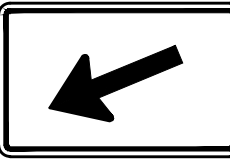
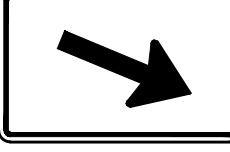

TRAFFIC SIGN SUMMARY													
IDENTIFI- CATION NUMBER	SIZE OF SIGN		TEXT	TEXT DIMENSIONS (INCHES)			NUMBER OF SIGNS REQUIRED	COLOR			POST SIZE AND NUMBER REQUIRED	UNIT AREA (S.F.)	AREA IN SQUARE FEET
	WIDTH	HEIGHT		LETTER HEIGHT	VERTICAL SPACING	ARROW RTE. MKR.		BACK- GROUND	LEGEND	BORDER			
R1-1	30"	30"		SEE FHWA "STANDARD HIGHWAY SIGNS, 2004 EDITION", AS AMENDED			1	RED	WHITE	WHITE		5.18	5.18
							2						10.36
							1						5.18
R5-1	30"	30"					0	RED	WHITE	WHITE		6.25	0.00
							2						12.50
							0						0.00
R7-1R	12"	18"					2	WHITE	RED	RED		1.50	3.00
							2						3.00
							1						1.50
R7-1L	12"	18"					3	WHITE	RED	RED		1.50	4.50
							3						4.50
							1						1.50
R7-8	12"	18"					1	WHITE	RED	RED		1.50	1.50
							0						0.00
							0						0.00
W11-2	30"	30"					4	YELLOW	BLACK	BLACK		6.25	25.00
							4						25.00
							4						25.00
W16-7pL	24"	12"					2	YELLOW	BLACK	BLACK		2.00	4.00
							2						4.00
							2						4.00
W16-7pR	24"	12"					2	YELLOW	BLACK	BLACK		2.00	4.00
							2						4.00
							2						4.00

← ADD ALT #1 - PROJECT SITE #1 (TYP)
 ← ADD ALT #2 - PROJECT SITE #2 (TYP)
 ← BASE BID - PROJECT SITE #3 (TYP)

NOTES:
 1. HIGH INTENSITY REFLECTIVE SHEETING SHALL BE USED FOR ALL SIGNS. SEE FHWA "STANDARD HIGHWAY SIGNS, 2004 EDITION" FOR TEXT DIMENSIONS, AS AMENDED; THE 1977 MASSHIGHWAY DEPARTMENT CONSTRUCTION AND TRAFFIC STANDARD DETAILS, AS AMENDED, FOR SIGNS AND SUPPORTS; THE MASSHIGHWAY DEPARTMENT SIGN LISTINGS 1993 EDITION, AS AMENDED; AND THE 2017 MASSDOT STANDARD SIGNS BOOK, AS AMENDED.
 2. ALL SIGNS SHOWN GRAPHICALLY FOR INFORMATION ONLY. SIGN VENDOR SHALL FABRICATE ALL SIGNS IN ACCORDANCE WITH THE APPLICABLE STANDARDS.

TEMPORARY TRAFFIC CONTROL GENERAL NOTES

- ALL CONSTRUCTION SIGNING, TEMPORARY TRAFFIC CONTROL DEVICES, AND ROADSIDE ELEMENTS SHALL CONFORM WITH THE 2009 MANUAL ON UNIFORM TRAFFIC CONTROL DEVICES (MUTCD) AS AMENDED, THE MASSDOT STANDARD DETAILS AND DRAWINGS FOR THE DEVELOPMENT OF TEMPORARY TRAFFIC CONTROL PLANS, THE LATEST REVISIONS OF THE AMERICAN ASSOCIATION OF STATE HIGHWAY AND TRANSPORTATION OFFICIALS, (AASHTO) ROADSIDE DESIGN GUIDE, AASHTO POLICY ON GEOMETRIC DESIGN OF HIGHWAYS AND STREETS, AND NATIONAL COOPERATIVE HIGHWAY RESEARCH PROGRAM (NCHRP) REPORT 350 OR THE AASHTO MANUAL FOR ASSESSING SAFETY HARDWARE (MASH).
- WORK HOURS SHALL BE 8:00AM TO 4:00PM MONDAY THRU FRIDAY UNLESS OTHERWISE APPROVED BY THE TOWN. WORK IMPACTING THE TRAVEL WAY WILL NOT BE ALLOWED DURING PEAK TRAFFIC PERIODS. PEAK PERIODS ARE DEFINED AS MONDAY THRU FRIDAY, 7:00AM TO 9:00AM AND 4:00PM TO 6:00PM. LANE CLOSURES WILL NOT BE PERMITTED FROM 5:30AM TO 9PM, MONDAY THRU FRIDAY.
- NO WORK SHALL OCCUR WITHIN THE PUBLIC WAY THE DAY BEFORE, AFTER OR ON A STATE RECOGNIZED HOLIDAY UNLESS OTHERWISE APPROVED BY THE TOWN.
- ALL TEMPORARY PEDESTRIAN PATHWAYS SHALL COMPLY FULLY WITH ALL REQUIREMENTS OF THE MUTCD AND ALL APPLICABLE MASSACHUSETTS ARCHITECTURAL ACCESS BOARD (MAAB) AND AMERICANS WITH DISABILITIES ACT ACCESSIBILITY GUIDELINES (ADAAG) REQUIREMENTS AND PUBLIC RIGHTS-OF-WAY ACCESSIBILITY GUIDELINES (PROWAG).
- ALL DRUMS OUTSIDE TAPERS SHALL BE SET AT 20' ON CENTER MAX. UNLESS OTHERWISE NOTED OR ADJUSTED BY THE ENGINEER.
- ALL DRUMS SHALL BE APPROXIMATELY PLACED AND MOVED AS NECESSARY TO MAINTAIN SAFE AND REASONABLE ABUTTER ACCESS. WORK MAY REQUIRE ADDITIONAL SIGNS, DRUMS AND OTHER TRAFFIC CONTROL DEVICES, GRADING AND TEMPORARY PAVEMENT FOR PASSAGE OF PEDESTRIAN, VEHICULAR AND EMERGENCY TRAFFIC THROUGH THE WORK AREAS, BOTH DURING AND AFTER WORKING HOURS, TO MAINTAIN SUCH ACCESS.
- THE FIRST 10 DRUMS ON TAPERS SHALL BE REFLECTORIZED DRUMS WITH SEQUENTIAL FLASHING WARNING LIGHTS AND SHALL BE OPERATING, AT A MINIMUM, BETWEEN DUSK AND DAWN, WHEN TAPER IS DEPLOYED.
- REFLECTORIZED CONES SHALL BE A MINIMUM OF 36 INCHES IN HEIGHT.
- CONES MAY BE USED IN LIEU OF DRUMS OUTSIDE OF TAPER AREAS.
- THE CONTRACTOR SHALL NOTIFY EACH ABUTTER AT LEAST 24 HOURS IN ADVANCE OF THE START OF ANY WORK THAT WILL REQUIRE THE TEMPORARY CLOSURE OR RESTRICTION OF ACCESS.
- FOR DROP-OFFS 3" OR LESS WITHIN THE CLEAR ZONE, CONDITION MAY BE MITIGATED WITH W8-9 (LOW SHOULDER) SIGN OR TEMPORARY CHANNELIZATION DEVICES. FOR DROP-OFFS GREATER THAN 3" BUT NO MORE THAN 36", DETERMINE WHETHER IT IS MORE COST EFFECTIVE TO INSTALL BOTH W8-9 SIGN AND TEMPORARY CHANNELIZATION DEVICES IN ACCORDANCE WITH MASSDOT WORK ZONE SAFETY GUIDE OR W8-9 SIGN WITH A 2H:1V (MIN) WEDGE OR TO REMOVE THE HAZARD. FOR DROP-OFFS 36" OR GREATER USE TEMPORARY BARRIER IN ACCORDANCE WITH MASSDOT WORK ZONE POSITIVE PROTECTION GUIDELINES.
- CONTRACTOR SHALL STAGE WORK SUCH THAT A DROP-OFF OF NO MORE THAN 3" AT THE END OF EACH WORK DAY EXISTS WITHIN THE CLEAR ZONE AT ANY TIME AND ENSURE DROP-OFF IS MITIGATED WITHOUT BARRIER PER NOTE 11.
- CONSTRUCTION CLEAR ZONE SHALL BE IN ACCORDANCE WITH MASSDOT BOSTON TRAFFIC GUIDELINES AS FOLLOWS:
4' IF POSTED SPEED IS LESS THAN 35 MPH
8' IF POSTED SPEED IS 35 MPH
15' IF POSTED SPEED IS 40 MPH
20' IF POSTED SPEED IS 45 MPH
- 11' MINIMUM LANE WIDTHS SHALL BE MAINTAINED UNLESS OTHERWISE NOTED.
- NON-ESSENTIAL TRAFFIC CONTROL DEVICES AND SIGNS SHALL BE COVERED OR REMOVED DURING NON-WORKING HOURS WHEN NOT IN USE.
- SIGNS INSTALLED ON PORTABLE STANDS REQUIRE 12 INCH MINIMUM MOUNTING HEIGHT FROM THE ROADWAY SURFACE TO THE BOTTOM OF THE SIGN.
- SIGNS INSTALLED ON PORTABLE STANDS PLACED AMONG CHANNELIZATION DEVICES REQUIRE A 36 INCH MINIMUM MOUNTING HEIGHT FROM THE ROADWAY SURFACE TO THE BOTTOM OF THE SIGN.
- SIGNS MOUNTED ON POSTS REQUIRE A MINIMUM 84 INCH MOUNTING HEIGHT FROM THE ROADWAY OR SIDEWALK SURFACE TO THE BOTTOM OF THE SIGN. CONTRACTOR SHALL MAINTAIN A MINIMUM SIDEWALK HORIZONTAL CLEAR WIDTH OF 36" AT ALL TIMES.
- ALL SIGNS SHALL BE MOUNTED ON THEIR OWN NCHRP 350 AND/OR MASH CRASH TESTED SIGN SUPPORTS AND INSTALLED IN ACCORDANCE WITH THE MUTCD.
- MA-W20-7b SIGNS SHALL BE REPLACED BY W20-7 SIGNS WHEN FLAGGERS ARE USED IN LIEU OF POLICE OFFICER DETAILS.
- W21-7 SIGNS SHALL BE INSTALLED IN ADVANCE (100' MIN) OF AREAS WHERE UTILITY CASTINGS HAVE BEEN RAISED IN ADVANCE OF PAVING OPERATIONS OR AS REQUESTED BY THE ENGINEER.
- W8-15 SIGNS SHALL BE INSTALLED IN ADVANCE (100' MIN) OF PAVEMENT MILLING AREAS OR AS REQUESTED BY THE ENGINEER.
- W20-1c OR MA-R2-10a SIGNS SHOWN ON ADVANCE SIGN SCHEMATIC MAY BE USED IN LIEU OF THOSE SIGNS SHOWN ON TYPICAL DETAILS ON THE TEMPORARY TRAFFIC CONTROL PLANS IF MINIMUM SIGN SPACING IS MET.
- CONTRACTOR SHALL SECURE WORK AREAS BY APPROPRIATE MEANS, TO PREVENT UNAUTHORIZED ACCESS AT ALL TIMES.
- WHEN UTILIZING TYPICAL TRAFFIC CONTROL DETAILS OR STAGING SETUPS, COVER EXISTING CONFLICTING ADVANCE WARNING SIGNS AS REQUIRED TO COMPLETE THE WORK.
- ALL TRAFFIC CONTROL DEVICES INCLUDING TEMPORARY CONSTRUCTION SIGNS, TEMPORARY PAVEMENT MARKINGS, REFLECTORIZED DRUMS, CONES, PORTABLE PEDESTRIAN BARRICADES, ARROW BOARDS, CONSTRUCTION FENCE, TEMPORARY CURB RAMPS, ROADWAY FLAGGERS AND ANY OTHER ITEMS ASSOCIATED WITH TEMPORARY TRAFFIC CONTROL SHALL BE PAID FOR AT A LUMP SUM COST UNDER ITEM 850.

NOTES:

- ADDITIONAL ADVANCE WARNING SIGNS MAY BE NECESSARY AS DETERMINED BY THE ENGINEER.
- CONTROLS FOR PEDESTRIAN TRAFFIC ONLY, ARE SHOWN. VEHICULAR TRAFFIC SHALL BE MAINTAINED AS SHOWN ELSEWHERE.
- STREET LIGHTING SHOULD BE CONSIDERED WHEN LOCATING CONTROL DEVICES.
- ← — → INDICATES DIRECTION OF PEDESTRIAN TRAVEL.
- IF THE WORK ZONE DOES NOT PERMIT PEDESTRIANS TO TRAVEL ADJACENT TO IT AS SHOWN IN PEDESTRIAN BYPASS TYPE I, THE APPROPRIATE SIGNS SHALL BE INSTALLED TO CROSS PEDESTRIANS TO THE OPPOSITE SIDE OF THE STREET AT EXISTING OR TEMPORARY CROSSWALKS AS SHOWN IN PEDESTRIAN BYPASS TYPE II, AND AS DIRECTED BY THE ENGINEER.
- ALL TEMPORARY PEDESTRIAN PATHWAYS SHALL COMPLY FULLY WITH ALL REQUIREMENTS OF THE MUTCD AND ALL APPLICABLE MAAB AND ADAAG REQUIREMENTS AND INCLUDE THE USE OF A COMPLIANT TEMPORARY PEDESTRIAN MANAGEMENT GUIDANCE SYSTEM AT ALL TIMES.
- CONTRACTOR SHALL MAINTAIN AS WIDE OF A PEDESTRIAN ACCESS AS POSSIBLE AT ALL TIMES. EXCEPT WHERE NECESSARY, THE CONTRACTOR MAY TEMPORARILY REDUCE PEDESTRIAN PATHWAYS TO 4 FEET IN WIDTH (EXCLUDING CURB) FOR NO MORE THAN 200 LINEAR FEET AT A TIME IN ACCORDANCE WITH ALL STANDARDS. A 5' x 5' PASSING AREA SHALL BE PROVIDED IN INTERVALS NOT EXCEEDING 200 FEET.
- TEMPORARY WHEELCHAIR RAMPS SHALL BE CONSTRUCTED IN ACCORDANCE WITH MASSDOT, MAAB, AND ADAAG REQUIREMENTS.

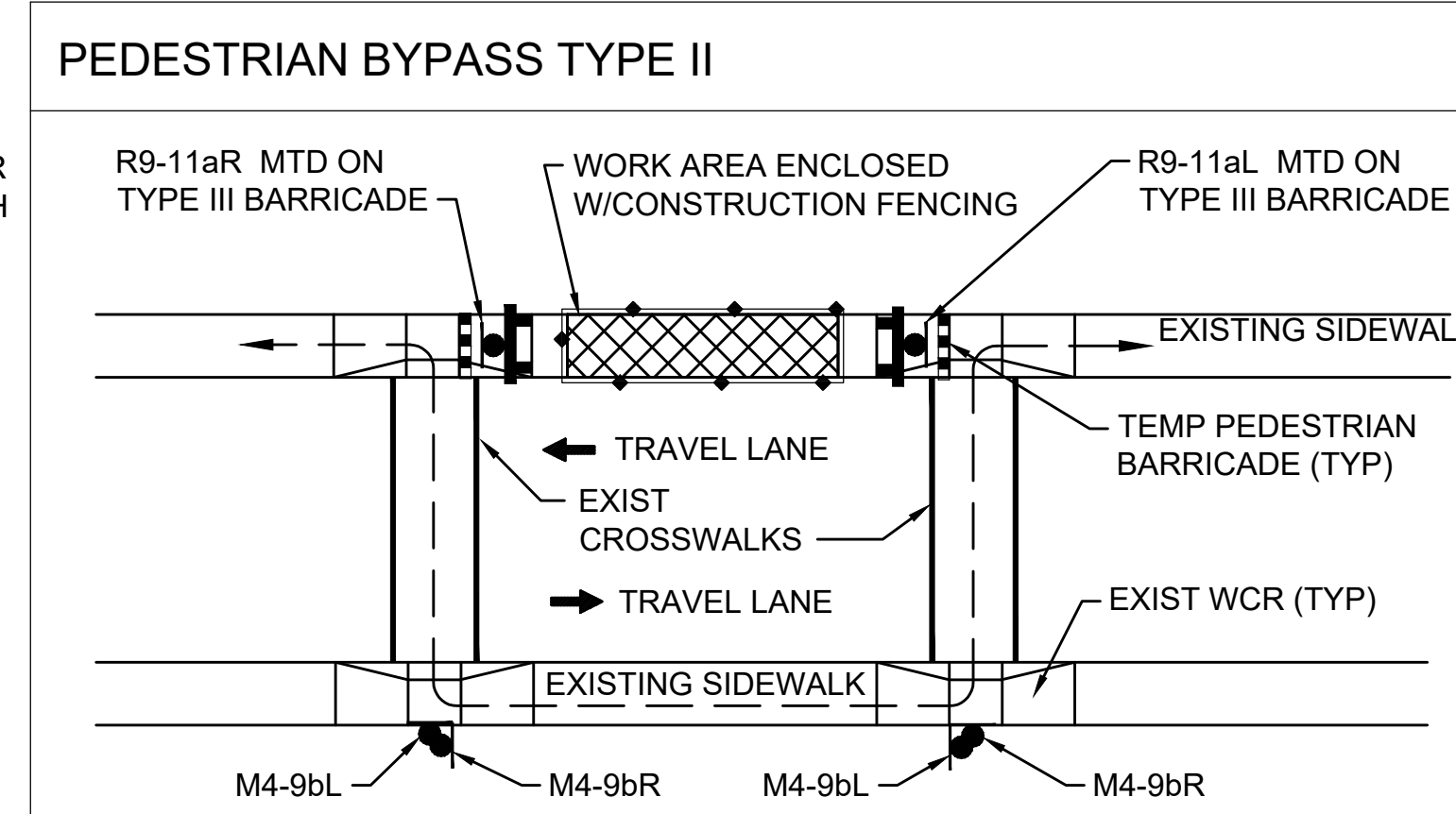
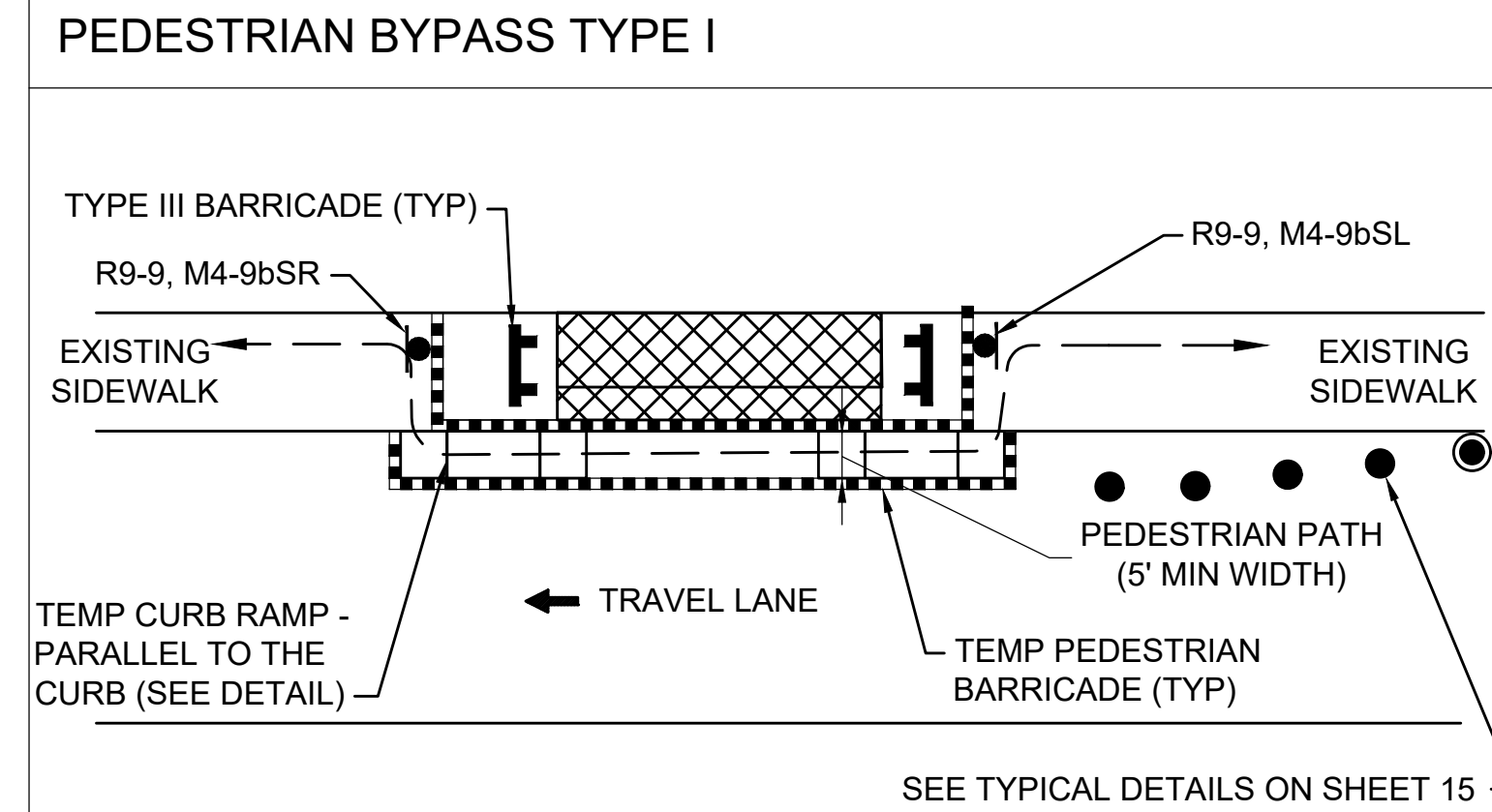

PEDESTRIAN BYPASS DETAIL

SCALE: NTS

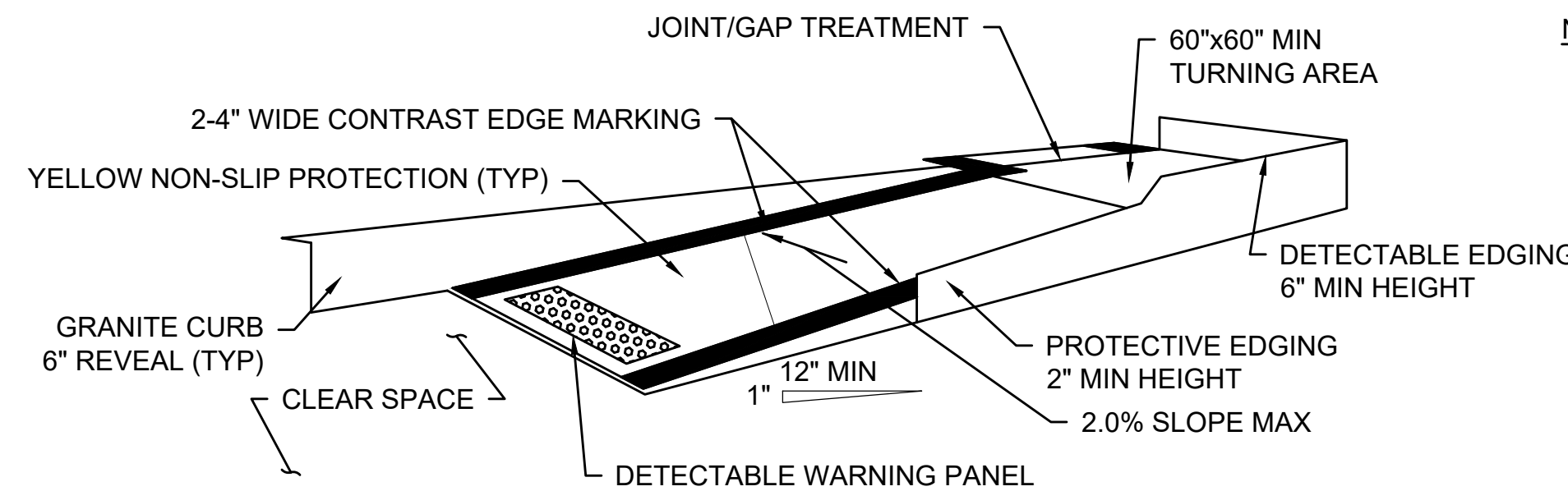

TEMPORARY CURB RAMP-PARALLEL TO CURB

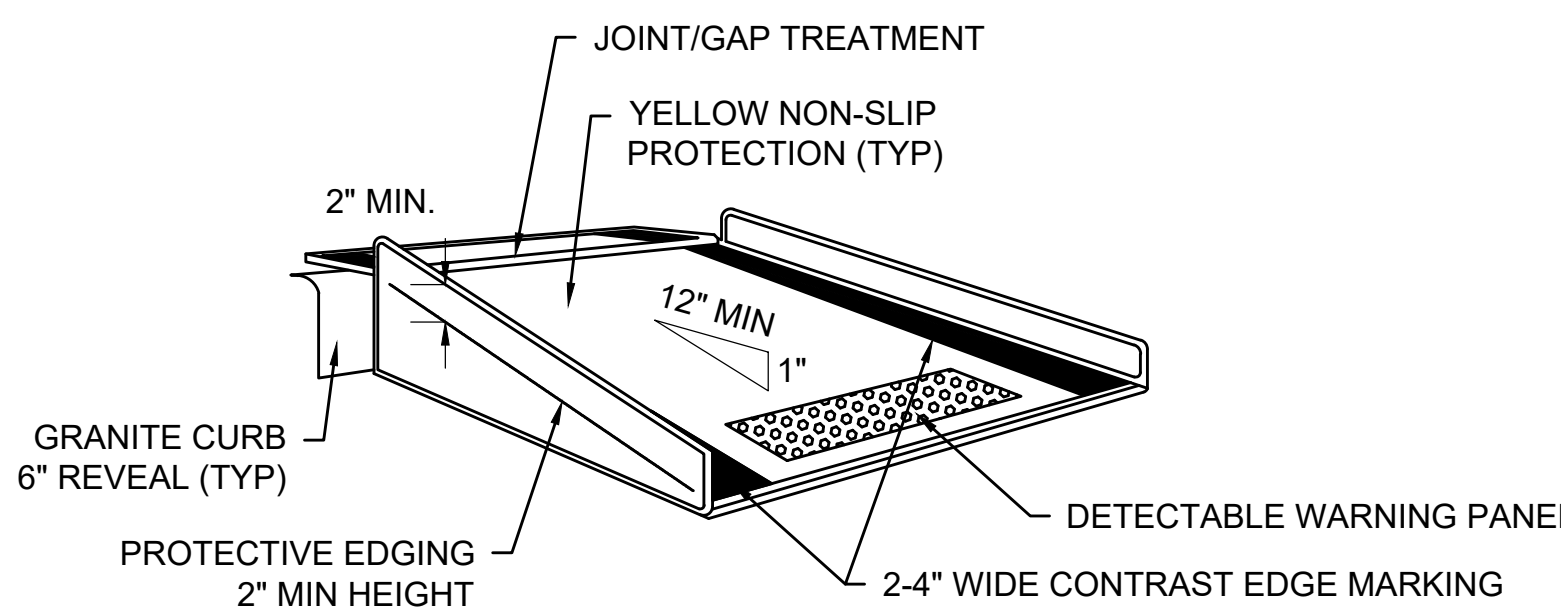

TEMPORARY CURB RAMP-PERPENDICULAR TO CURB

TEMPORARY CURB RAMPS

SCALE: NTS

NOTES:

- CURB RAMPS SHALL BE 60" MINIMUM WIDTH WITH A FIRM, STABLE AND NON-SLIP SURFACE. PROTECTIVE EDGING WITH A 2" MINIMUM HEIGHT SHALL BE INSTALLED WHEN THE CURB RAMP OR LANDING PLATFORM HAS A VERTICAL DROP OF 6" OR GREATER OR HAS A SIDE APRON SLOPE STEEPER THAN 1:3 (33%). PROTECTIVE EDGING SHOULD BE CONSIDERED WHEN THE CURB RAMPS OR LANDING PLATFORMS HAVE A VERTICAL DROP OF 3" OR MORE.
- DETECTABLE EDGING WITH 6" MINIMUM HEIGHT AND CONTRASTING COLOR SHALL BE INSTALLED ON ALL CURB RAMP LANDINGS WHERE THE WALKWAY CHANGES DIRECTION (TURNS).
- THE CURB RAMP WALKWAY AND LANDING AREA SURFACE SHALL BE OF A SOLID CONTINUOUS CONTRASTING COLOR ABUTTING UP TO THE EXISTING SIDEWALK.
- CURB RAMPS AND LANDINGS SHOULD HAVE A 1:50 (2%) MAX CROSS-SLOPE.
- CLEAR SPACE OF 48"x48" MINIMUM SHALL BE PROVIDED ABOVE AND BELOW THE CURB RAMP.
- WATER FLOW IN THE GUTTER SYSTEM SHALL HAVE MINIMAL RESTRICTION.
- LATERAL JOINTS OR GAPS BETWEEN SURFACES SHALL BE LESS THAN 0.5" WIDTH.
- CHANGES BETWEEN SURFACE HEIGHTS SHOULD NOT EXCEED 0.5" LATERAL EDGES SHOULD BE VERTICAL UP TO 0.25" HIGH, AND BEVELED AT 1:2 BETWEEN 0.25" AND 0.5" HEIGHT.
- IF A TEMPORARY PEDESTRIAN RAMP LEADS TO A CROSSWALK, THEN A DETECTABLE WARNING PAD MUST BE ADHERED TO THE BASE OF THE RAMP. IF IT LEADS TO A PROTECTED PEDESTRIAN BYPASS THAT DOES NOT CONFLICT WITH VEHICULAR TRAFFIC, THEN A PAD SHALL NOT BE INSTALLED ON THE RAMP.

LEGEND

	POLICE OFFICER
	TRAFFIC SIGNAL
	REFLECTORIZED DRUM
	REFLECTORIZED DRUMS WITH SEQUENTIAL FLASHING WARNING LIGHTS (SEE NOTE 7)
	TEMPORARY CONSTRUCTION SIGN
	TRAFFIC CONE
	TYPE III BARRICADE
	ARROW BOARD (AB) (RIGHT OR LEFT)
	WORK AREA (PUBLIC ACCESS RESTRICTED)
	TRAFFIC FLOW
	PEDESTRIAN ROUTE
	CONSTRUCTION FENCE
	TEMPORARY PORTABLE PEDESTRIAN BARRICADE
NTS	NOT TO SCALE

ADVANCE SIGN SPACING

ROADWAY	DISTANCE BETWEEN SIGNS (FEET)			
	A	B	C	D
ALL ROADS	100	50	100	100

BUFFER SPACING

SPEED (MPH)	DISTANCE (FEET)
15	80
20	115
25	155
30	200

LANE TAPER LENGTH FORMULAS

L= TAPER LENGTH IN FEET
W= WIDTH OF ROADWAY TO BE SHIFTED OR REDIRECTED IN FEET
S= POSTED SPEED LIMIT IN MPH
POSTED SPEED
40 MPH OR LESS
$L = \frac{WS^2}{60}$

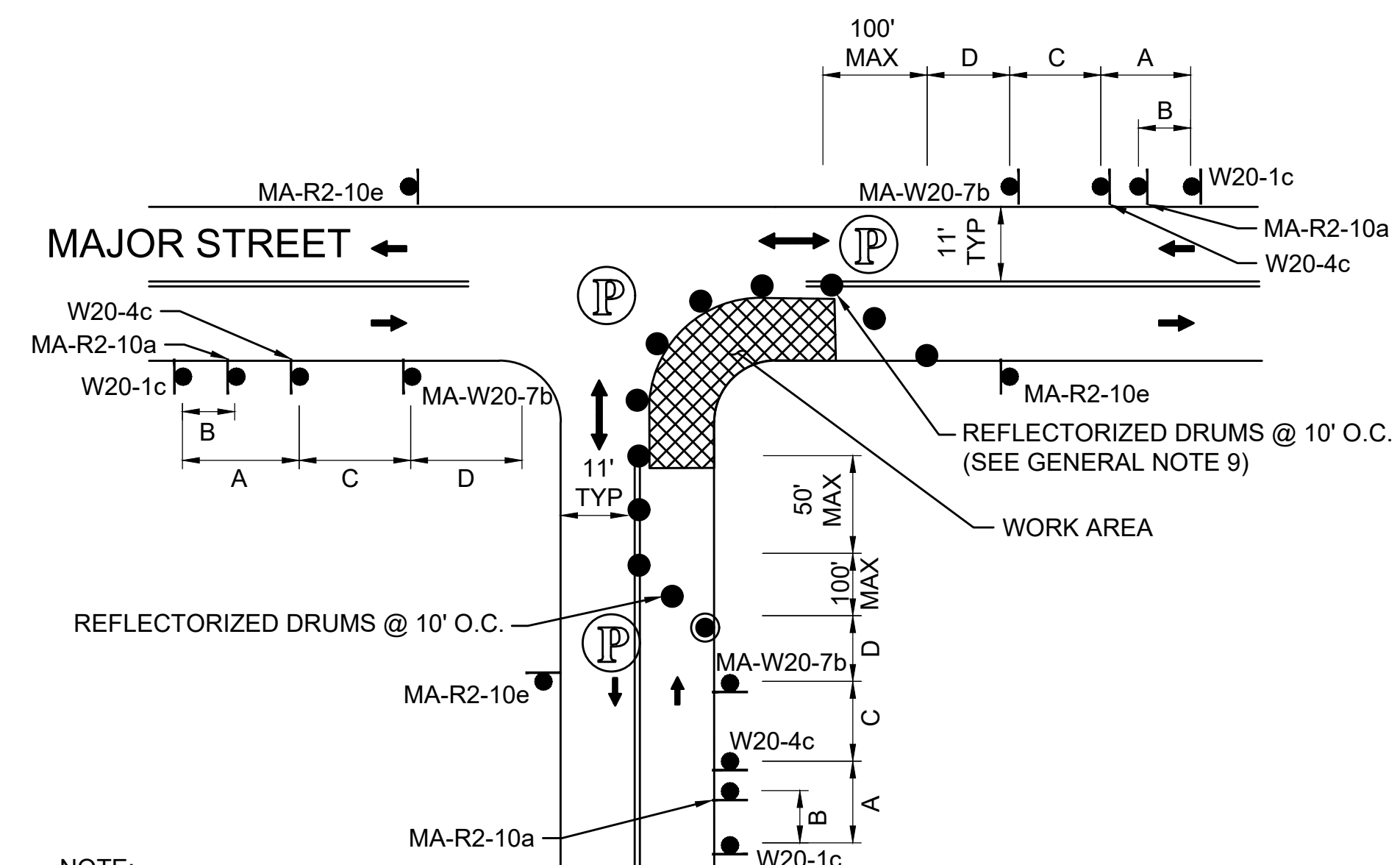

- NOTE:
1. ADVANCE WARNING SIGN PLACEMENT TO BE ADJUSTED AS NECESSARY.
 2. REFER TO ADVANCE SIGN SPACING TABLE ON SHEET 15.

ONE LANE BI-DIRECTIONAL TRAFFIC AT INTERSECTIONS - FAR SIDE

SCALE: NTS

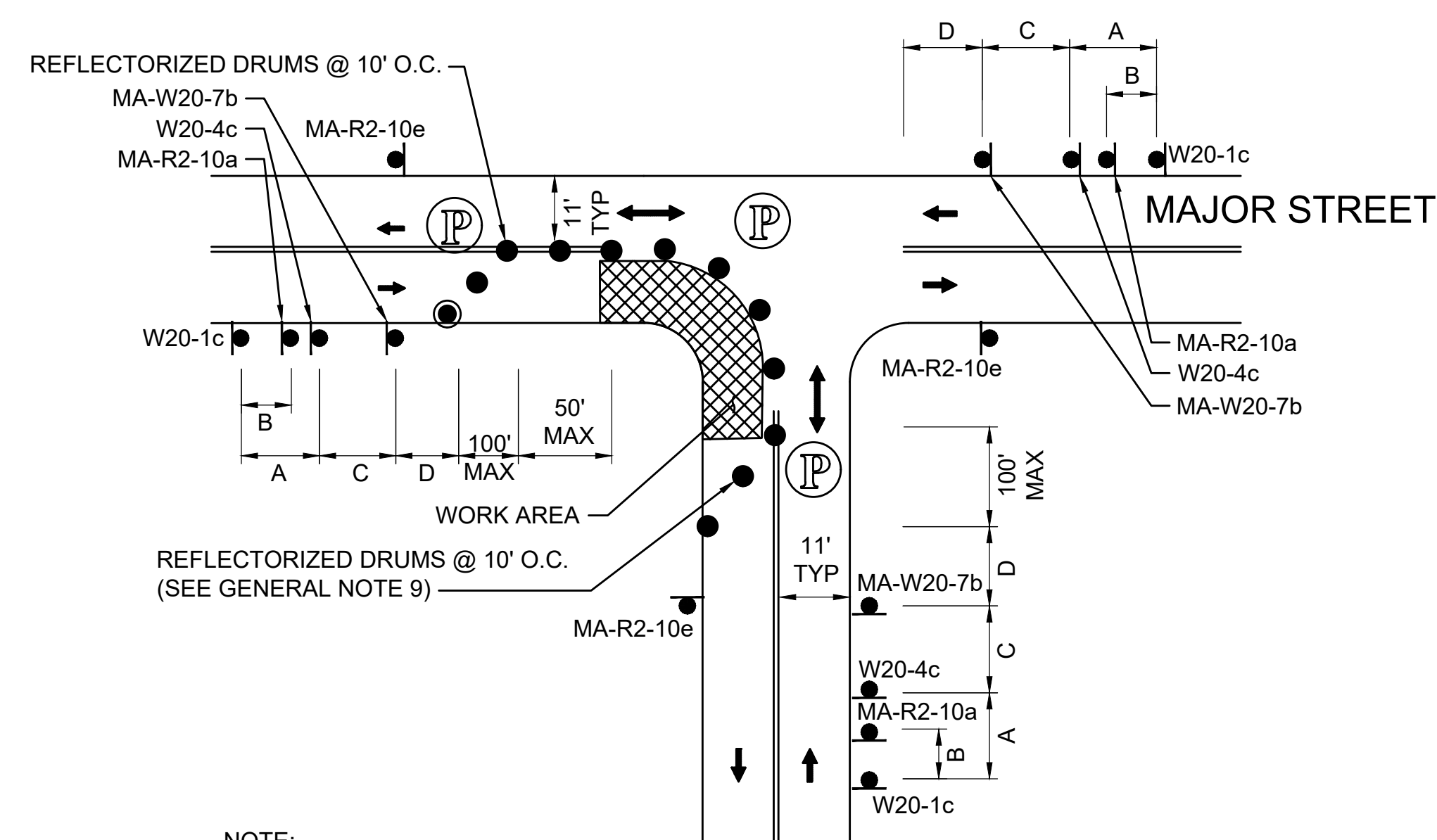

- NOTE:
1. ADVANCE WARNING SIGN PLACEMENT TO BE ADJUSTED AS NECESSARY.
 2. REFER TO ADVANCE SIGN SPACING TABLE ON SHEET 15.

ONE LANE BI-DIRECTIONAL TRAFFIC AT INTERSECTIONS - NEAR SIDE

SCALE: NTS

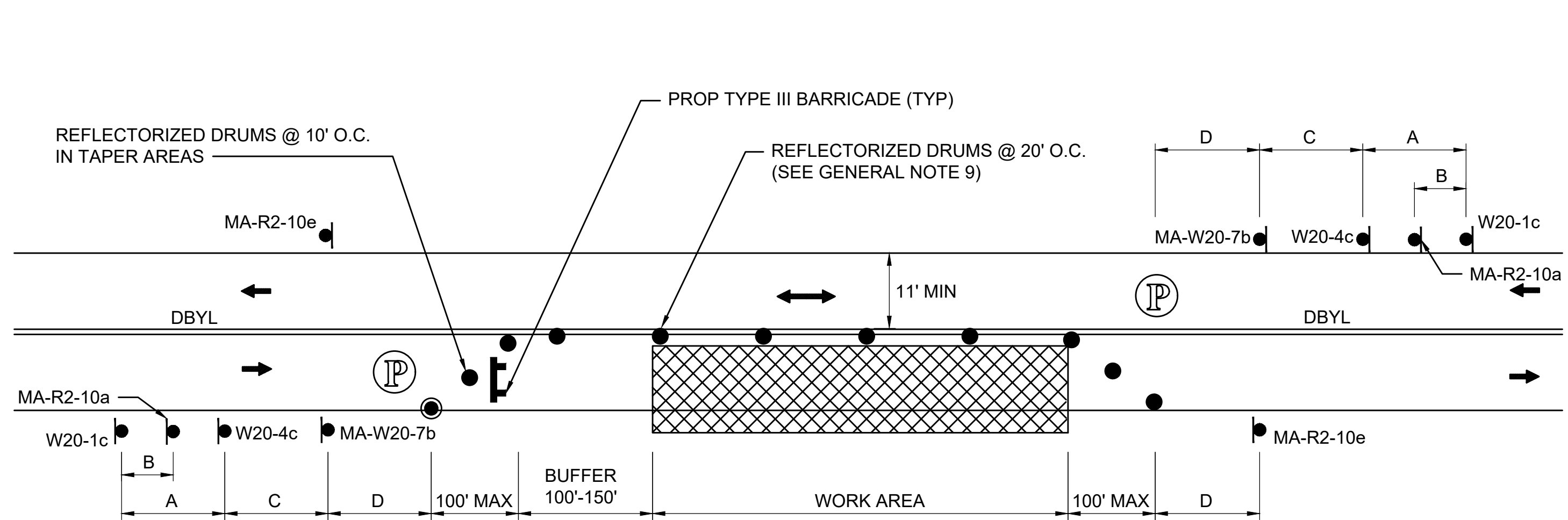

- NOTES:
1. REFER TO ADVANCE SIGN SPACING TABLE ON SHEET 15.

TYPICAL TWO-WAY STREET LANE CLOSURE ALTERNATING TRAFFIC

SCALE: NTS

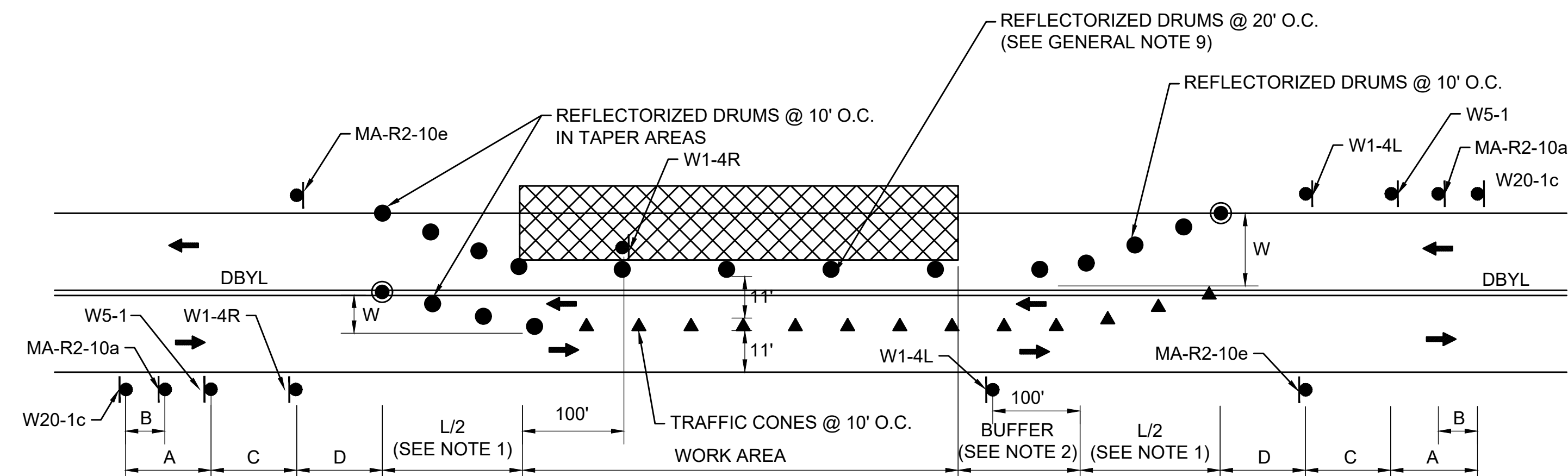

- NOTES:
1. SEE TAPER LENGTH FORMULA ON SHEET 15.
 2. SEE BUFFER SPACING CHART ON SHEET 15.
 3. REFER TO ADVANCE SIGN SPACING TABLE ON SHEET 15.

TYPICAL TWO-WAY STREET LANE SHIFT

SCALE: NTS

WHEELCHAIR RAMP DETAIL - 12.0' OR GREATER - CURVED											
NO.	LOCATION	SIDEWALK WIDTH	RAMP WIDTH	RAMP LENGTH	LEFT SIDE		RIGHT SIDE		ELEVATION		NOTES
					ROADWAY GUTTER	TRANS	ROADWAY GUTTER	TRANS	OPENING	BACK OF LEVEL LANDING	
3	STA 20+24.7, 17.3' LT ALGN - SCHOOL STREET	20'-0"	5'-0"	6'-0"	-0.7%	6'-6"	-2.2%	6'-6"	13.87	13.88	3" REVEAL LEFT/RIGHT SIDE
4	STA 11+38.8, 24.0' LT ALGN - CENTRAL STREET	13'-0"	5'-0"	8'-6"	-4.8%	6'-6"	2.3%	11'-0"	14.12	14.57	8" REVEAL LEFT SIDE 3" REVEAL RIGHT SIDE
5	STA 10+93.9, 14.0' RT ALGN - CENTRAL STREET	14'-7"	5'-0"	8'-6"	1.5%	9'-0"	-1.4%	6'-6"	14.12	14.70	4" REVEAL ON LEFT SIDE
8	STA 31+25.9, 17.0' LT ALGN - UNION STREET	14'-3"	5'-0"	10'-0"	-5.6%	6'-6"	7.8%	15'-0"	25.14	25.94	
9	STA 40+66.2, 18.8' LT ALGN - BEACH STREET	11'-6"	5'-0"	7'-6"	-6.1%	6'-6"	2.3%	11'-0"	19.52	20.04	8" REVEAL ON LEFT SIDE 5" REVEAL ON RIGHT SIDE

WHEELCHAIR RAMP DETAIL - GREATER THAN 6.5 FEET - CURVED												
NO.	LOCATION	SIDEWALK WIDTH	RAMP WIDTH	W1	W2	LEFT SIDE		RIGHT SIDE		ELEVATION		NOTES
						ROADWAY GUTTER	TRANS	ROADWAY GUTTER	TRANS	OPENING	BACK OF WALK	
10	STA 40+53.8, 22.8' RT ALGN - BEACH STREET	11'-0"	5'-0"	6'-6"	4'-6"	10.9%	15'-0"	-8.8%	6'-6"	20.65	21.22	SEE PLAN FOR LAYOUT OF RIGHT SIDE TRANSITION
12	STA 52+23.2, 15.9' LT ALGN - SUMMER STREET	9'-6"	5'-0"	5'-6"	4'-0"	-2.3%	6'-6"	1.7%	9'-0"	41.07	41.54	
16	STA 70+49.0, 18.2' LT ALGN - WASHINGTON ST	8'-6"	5'-0"	4'-6"	4'-0"	0.4%	7'-8"	1.8%	9'-0"	40.55	40.95	

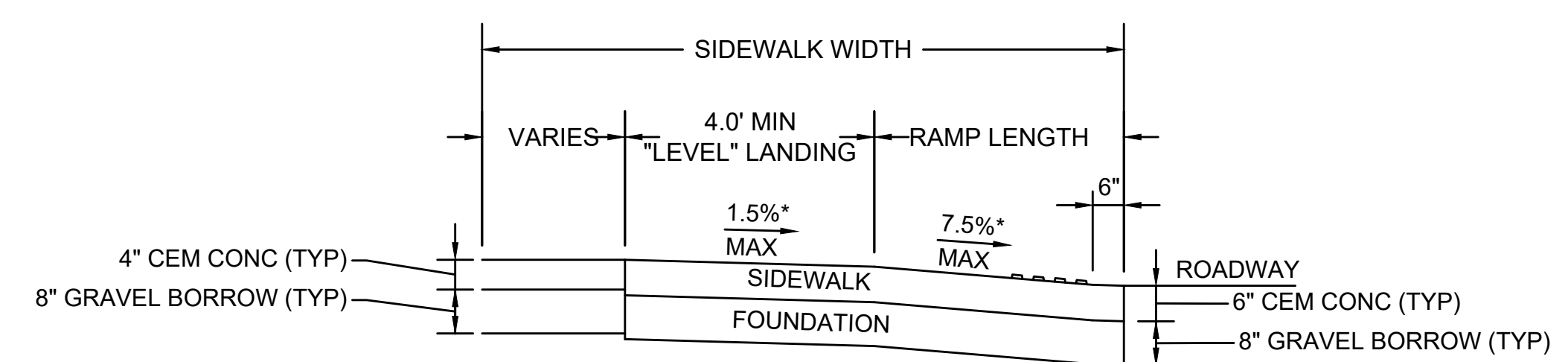

LEGEND

- LIMITS OF CEM CONC RAMP
- DETECTABLE WARNING PANEL

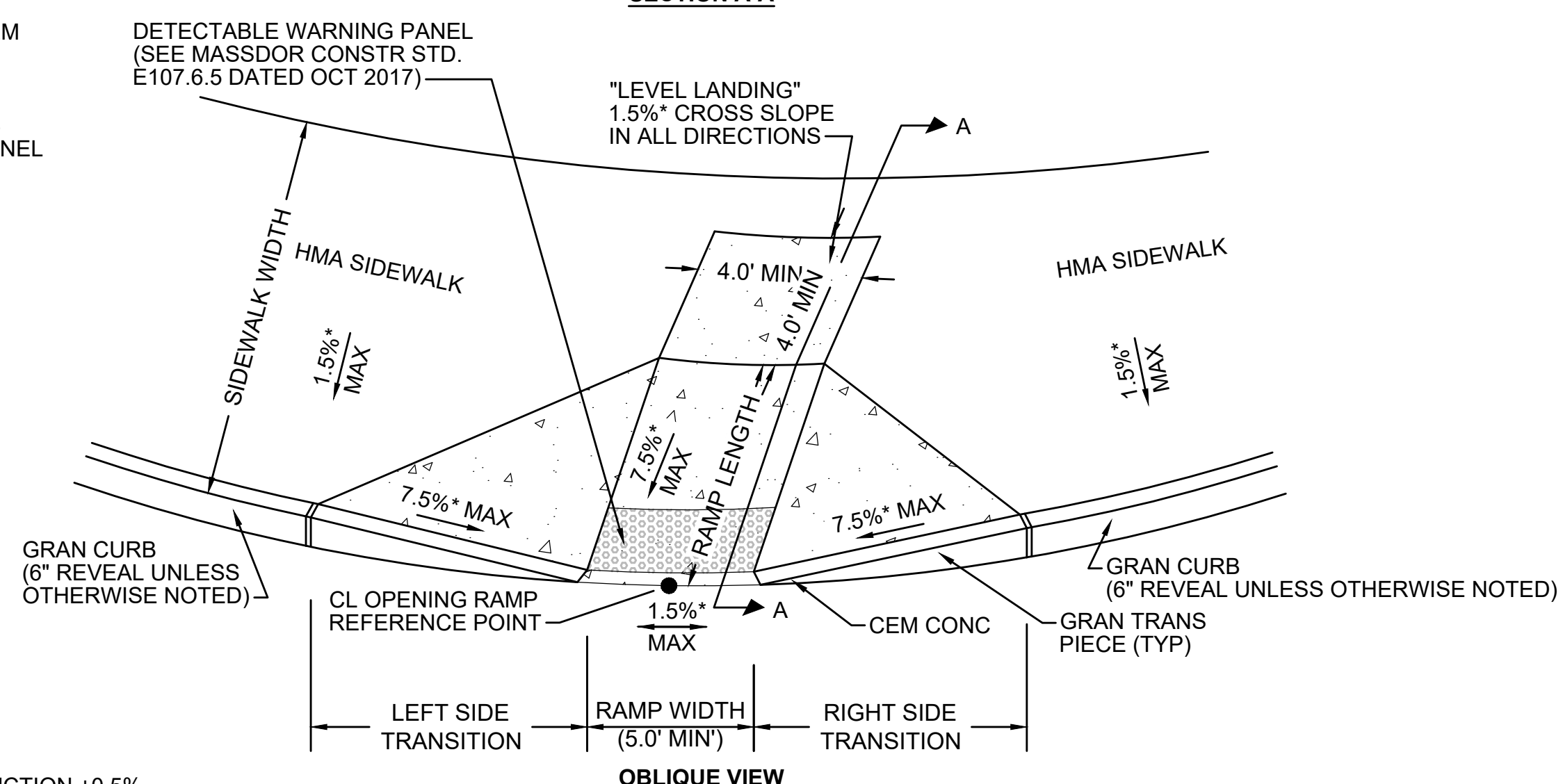

*TOLERANCE FOR CONSTRUCTION ±0.5%

WHEELCHAIR RAMP - 12.0' OR GREATER - CURVED
SCALE: N.T.S.

LEGEND

- LIMITS OF CEM CONC RAMP
- DETECTABLE WARNING PANEL

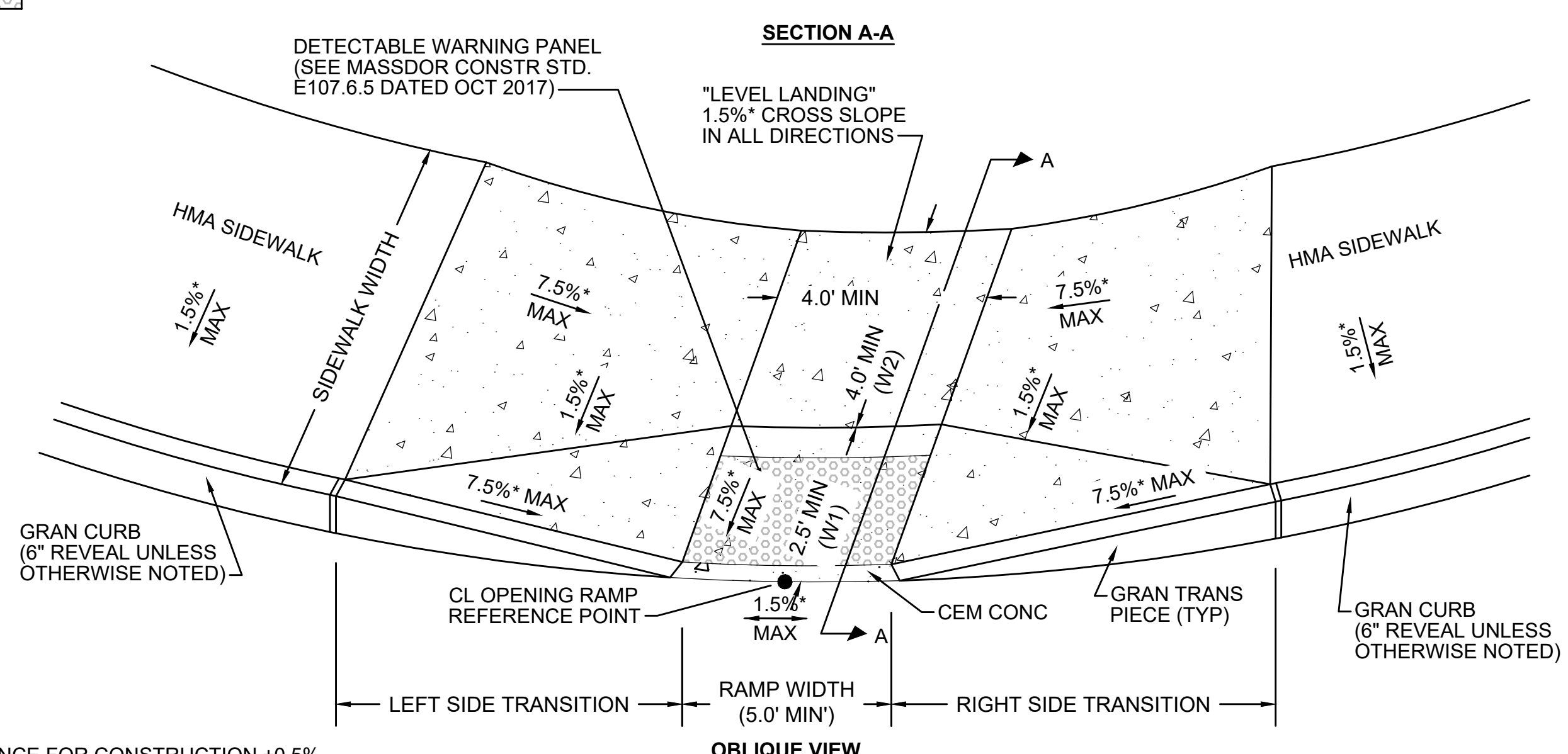
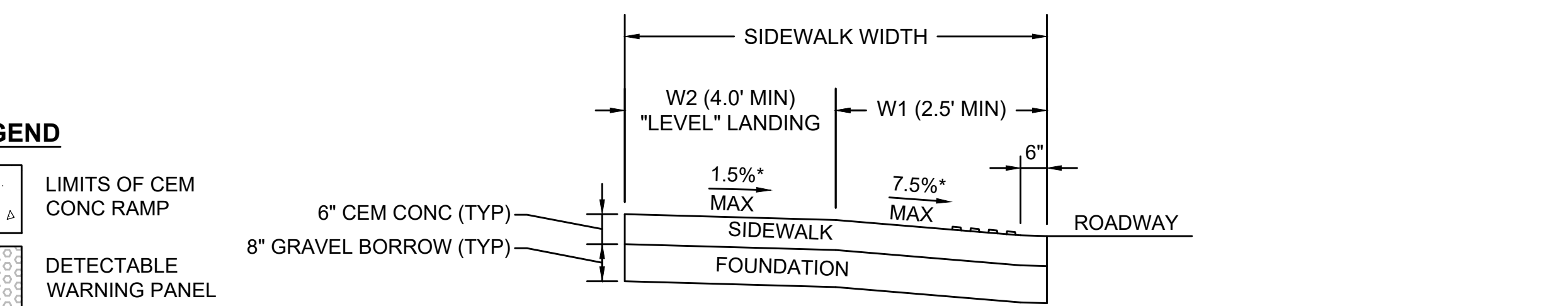

*TOLERANCE FOR CONSTRUCTION ±0.5%

WHEELCHAIR RAMP - GREATER THAN 6.5 FEET - CURVED
SCALE: N.T.S.

WHEELCHAIR RAMP DETAIL - "T" INTERSECTION							
NO.	LOCATION	LEFT SIDE		RIGHT SIDE		OPENING ELEVATION	NOTES
		ROADWAY GUTTER	TRANS	ROADWAY GUTTER	TRANS		
7	STA 11+75.5, 23.2' RT ALGN - CENTRAL ST	2.1%	11'-0"	0.6%	7'-8"	15.41	
13	STA 60+94.9, 15.7' LT ALGN - SEA ST	-9.7%	6'-6"	-6.2%	6'-6"	31.62	

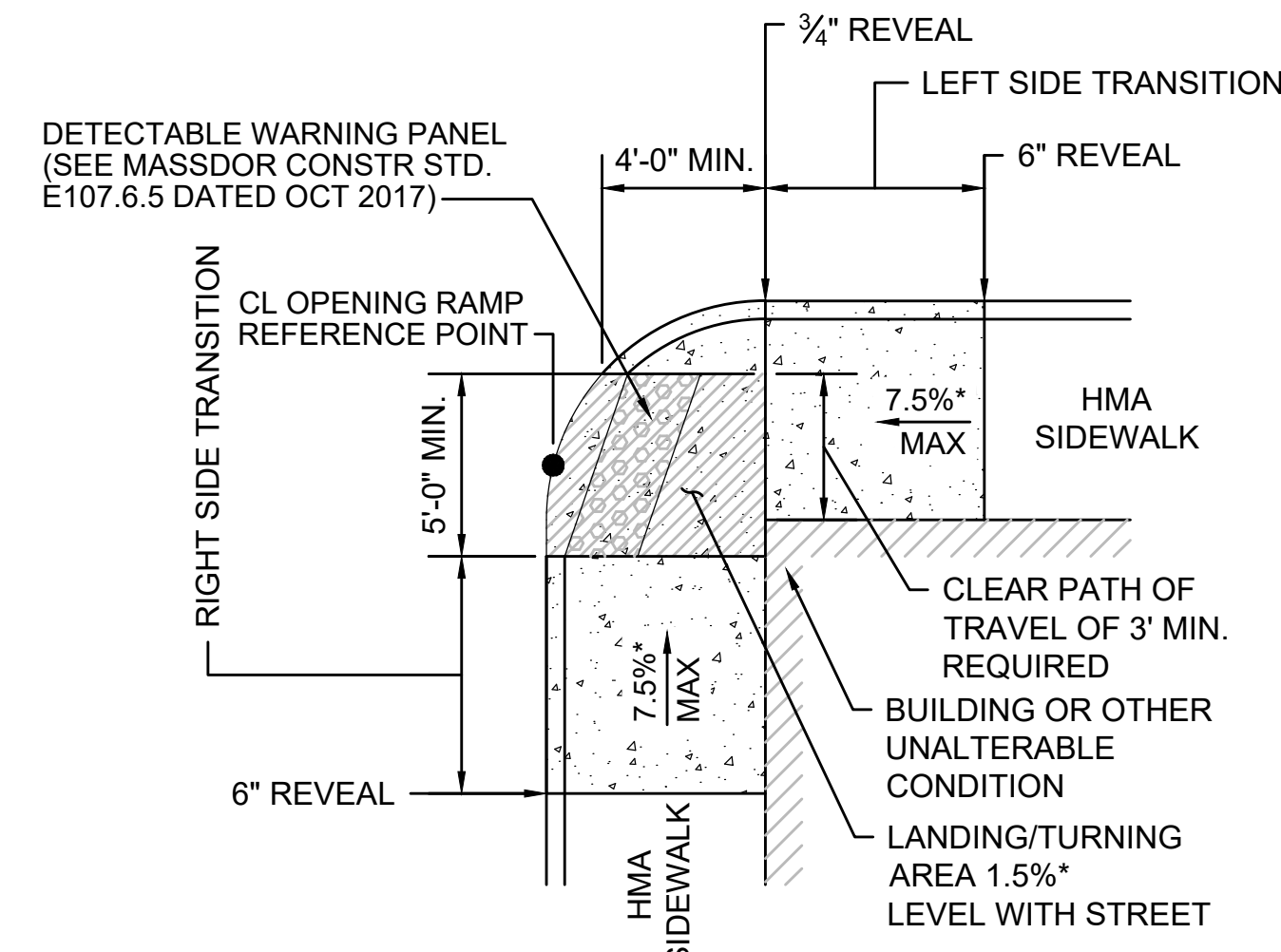

*TOLERANCE FOR CONSTRUCTION ±0.5%

"T" INTERSECTION WHEELCHAIR RAMP

SCALE: N.T.S.

WHEELCHAIR RAMP DETAIL - LESS THAN 6.5 FEET - CURVED										
NO.	LOCATION	SIDEWALK WIDTH	RAMP WIDTH	LEFT SIDE		RIGHT SIDE		ELEVATION		NOTES
				ROADWAY GUTTER	TRANS	ROADWAY GUTTER	TRANS	OPENING	BACK OF WALK	
1	STA 31+30.3, 5.0' RT ALGN - UNION STREET	5'-2"	5'-0"	8.7%	15'-0"	-11.7%	6'-6"	24.51	24.59	3" REVEAL RIGHT SIDE 5" REVEAL LEFT SIDE
11	STA 52+16.0, 15.0' RT ALGN - SUMMER STREET	5'-6"	5'-0"	4.6%	15'-0"	-7.9%	6'-6"	40.11	40.19	

LEGEND

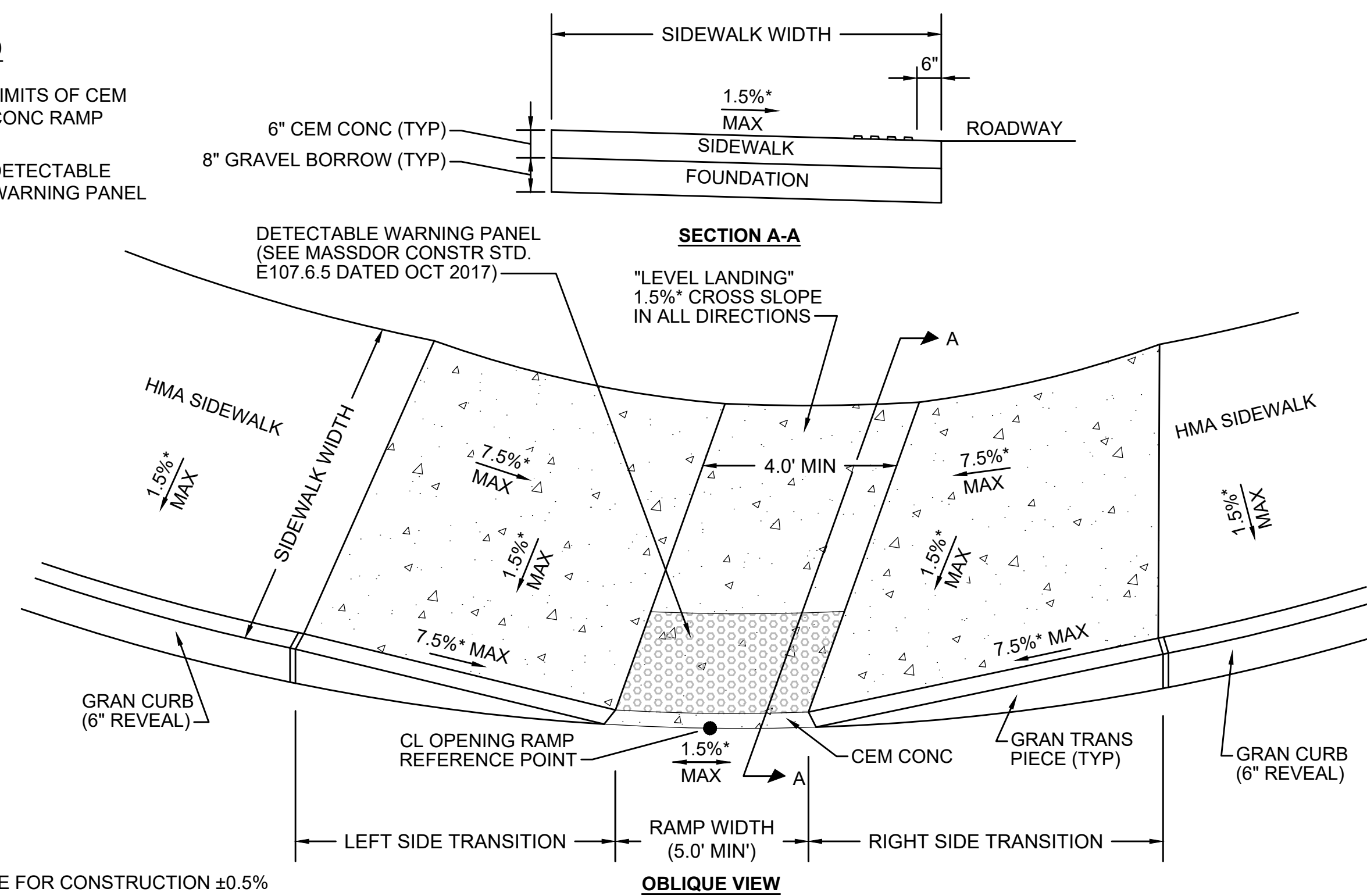
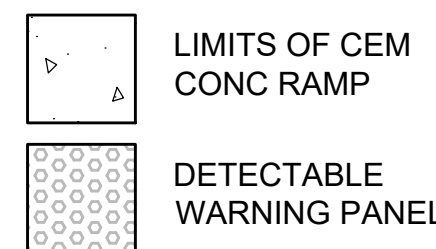

*TOLERANCE FOR CONSTRUCTION ±0.5%

WHEELCHAIR RAMP - LESS THAN 6.5 FEET - CURVED

SCALE: N.T.S.

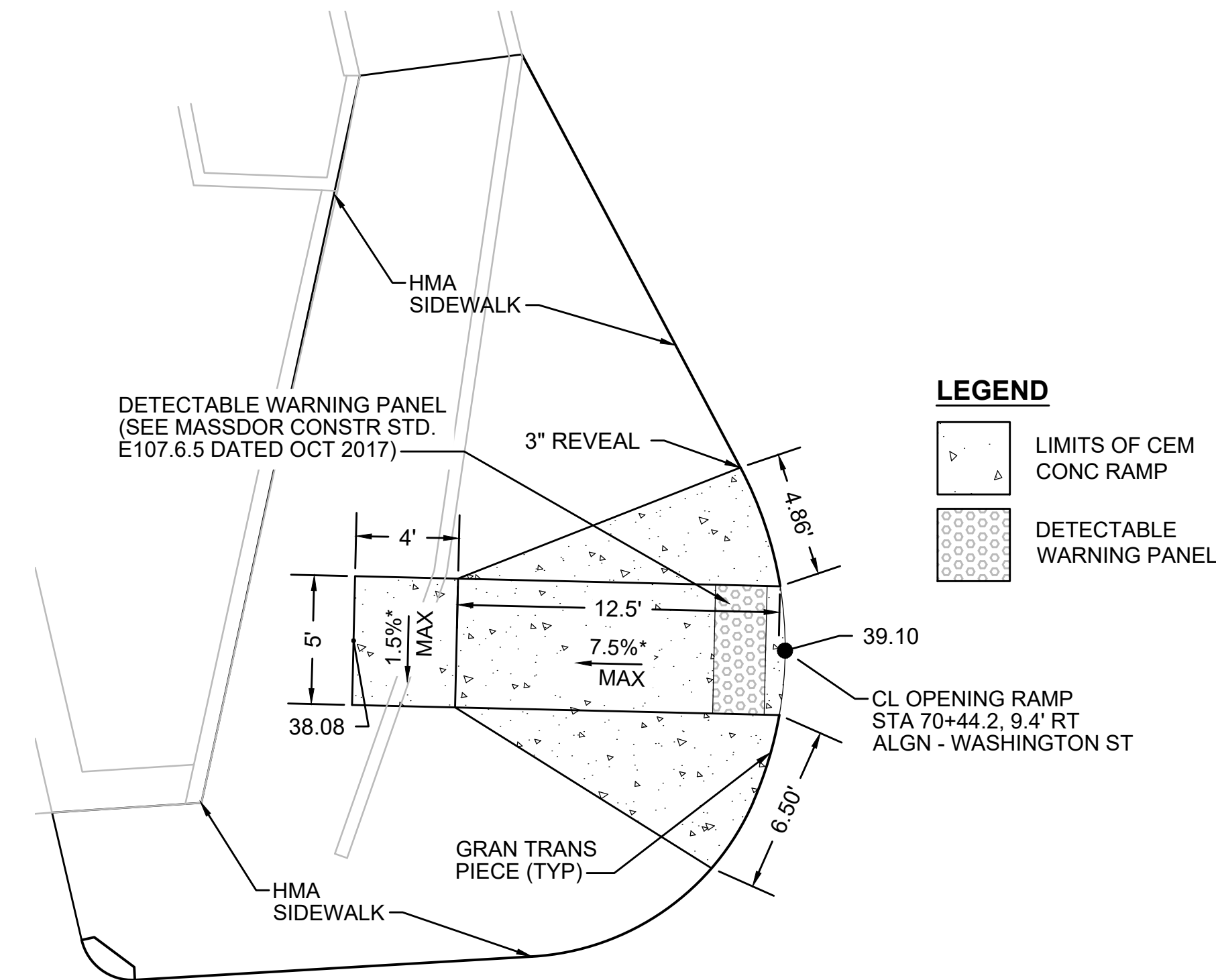

*TOLERANCE FOR CONSTRUCTION ±0.5%

WHEELCHAIR RAMP NO. 15 DETAIL

SCALE: N.T.S.

WHEELCHAIR RAMP DETAIL - LESS THAN 6.5 FEET - CURVED											
NO.	LOCATION	SIDEWALK WIDTH	RAMP WIDTH	LEFT SIDE		RIGHT SIDE		ELEVATION (ALONG CL OF RAMP)			NOTES
				ROADWAY GUTTER	TRANS	ROADWAY GUTTER	TRANS	OPENING	BOT OF RAMP	TOP OF RAMP	
6	STA 11+48.3, 25.5' RT ALGN - CENTRAL STREET	6'-3"	3'-0"	-	-	-1.5%	6'-6"	14.53	14.55	14.87	
14	STA 51+59.3, 20.5' RT ALGN - SUMMER STREET	8'-10"	3'-0"	11.3%	15'-0"	-	-	34.82	35.07	37.14	

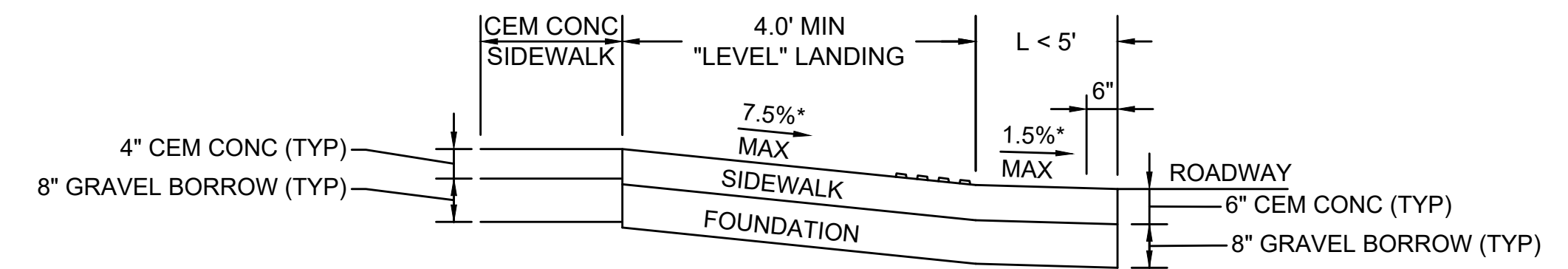

SECTION A-A

LEGEND

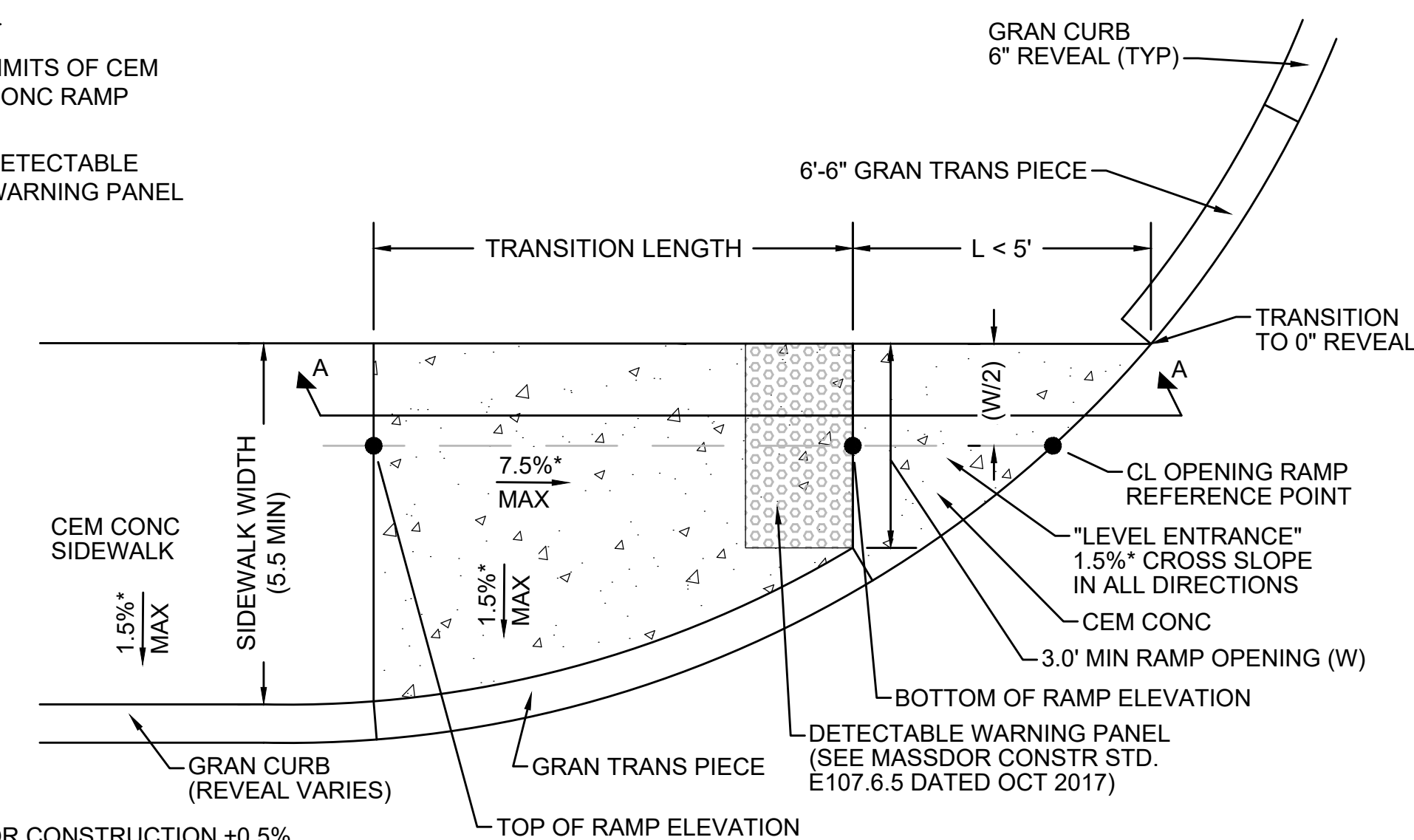
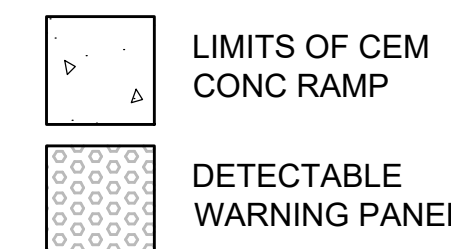

*TOLERANCE FOR CONSTRUCTION ±0.5%

WHEELCHAIR RAMP - 'L' IS LESS THAN 5'

SCALE: N.T.S.

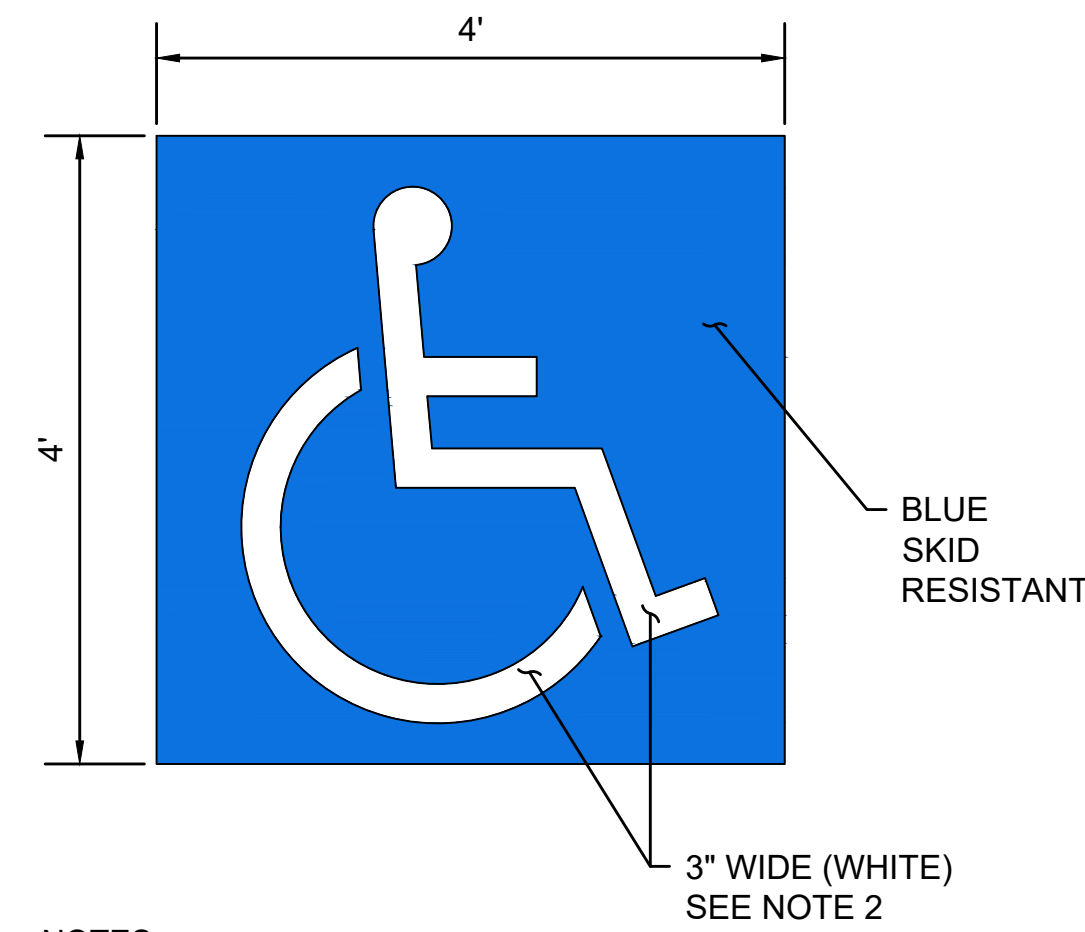

- NOTES:
1. ACCESSIBLE PARKING PAVEMENT MARKINGS SHALL CONFORM TO THE RELEVANT PROVISIONS OF THE MASSACHUSETTS HIGHWAY DEPARTMENT "STANDARD SPECIFICATION FOR HIGHWAY AND BRIDGES" DATED 1988, SECTION 860 FOR REFLECTORIZED LINE (THERMO-PLASTIC) & MATERIAL M7.01.20, LATEST REVISIONS.
 2. LAYOUT SHALL CONFORM TO THE INTERNATIONAL SYMBOL OF ACCESSIBILITY PARKING SPACE MARKING WITH BLUE BACKGROUND AND WHITE BORDER AS DEFINED IN THE LATEST STANDARD HIGHWAY SIGNS (FHWA).

ACCESSIBLE PARKING PAVEMENT MARKING
SCALE: N.T.S.

- NOTES:
1. ALL HOT MIX ASPHALT WALKS SHALL BE ESTIMATED AND PAID FOR UNDER ITEM 702 OF STANDARD SPECIFICATIONS FOR HIGHWAYS AND BRIDGES.
 2. ASPHALT EMULSION FOR TACK COAT (ITEM 452.) SHALL BE SPRAY APPLIED FOR DOUBLE OVERLAP COVERAGE AT 0.07 GALLONS PER SQUARE YARD OVER MILLED SURFACES AND 0.05 GALLONS PER SQUARE YARD OVER SMOOTH SURFACES.
 3. HMA JOINT SEALANT (ITEM 453.) SHALL BE APPLIED IN SURFACE COURSE AT ALL VERTICAL COLD JOINTS PRIOR TO HMA PAVING.

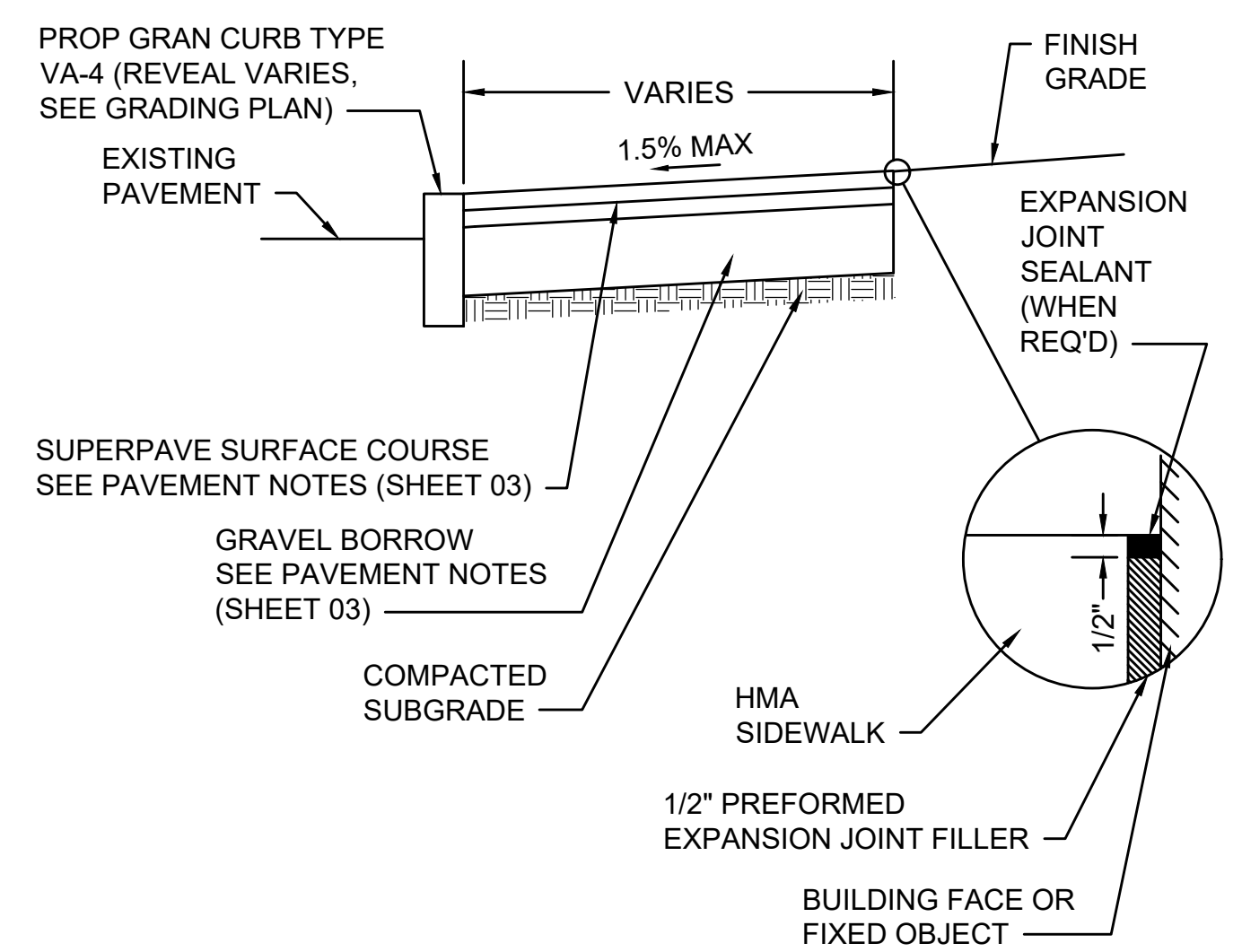

HOT MIX ASPHALT SIDEWALK
SCALE: N.T.S.

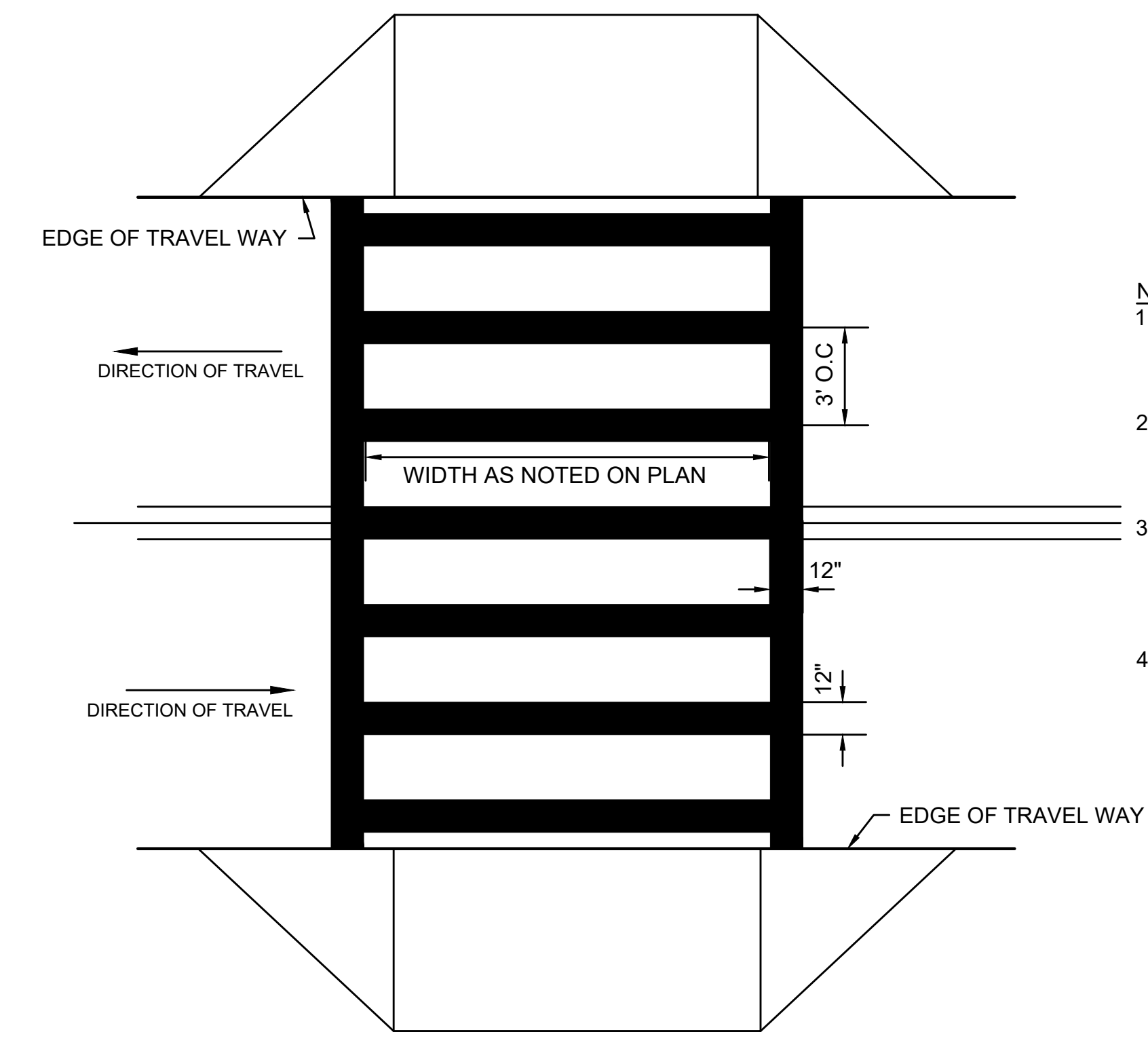

- NOTES:
1. ALL EXISTING CROSSWALK MARKINGS SHALL BE FULLY ERADICATED BY APPROVED METHOD PRIOR TO THE APPLICATION OF PROPOSED MARKINGS.
 2. ALL 12" THERMOPLASTIC LINES SHALL BE APPLIED IN ONE APPLICATION, NO COMBINATION OF LINES (TWO - 6" LINES) WILL BE ACCEPTED.
 3. LAYOUT OF CROSSWALKS SHALL BE ORIENTATED IN THE DIRECTION OF TRAVEL AND LOCATED OUTSIDE OF THE WHEEL PATH OF VEHICLES. LAYOUT SHALL BE APPROVED BY THE ENGINEER PRIOR TO APPLICATION OF THERMOPLASTIC.
 4. ALL CROSSWALKS INSTALLED SHALL CONFORM TO THE RELEVANT PROVISIONS OF THE MASSACHUSETTS HIGHWAY DEPARTMENT "STANDARD SPECIFICATION FOR HIGHWAY AND BRIDGES" DATED 1988, SECTION 860 FOR REFLECTORIZED LINE (THERMO-PLASTIC) & MATERIAL M7.01.20, LATEST REVISIONS.

CROSSWALK
SCALE: N.T.S.

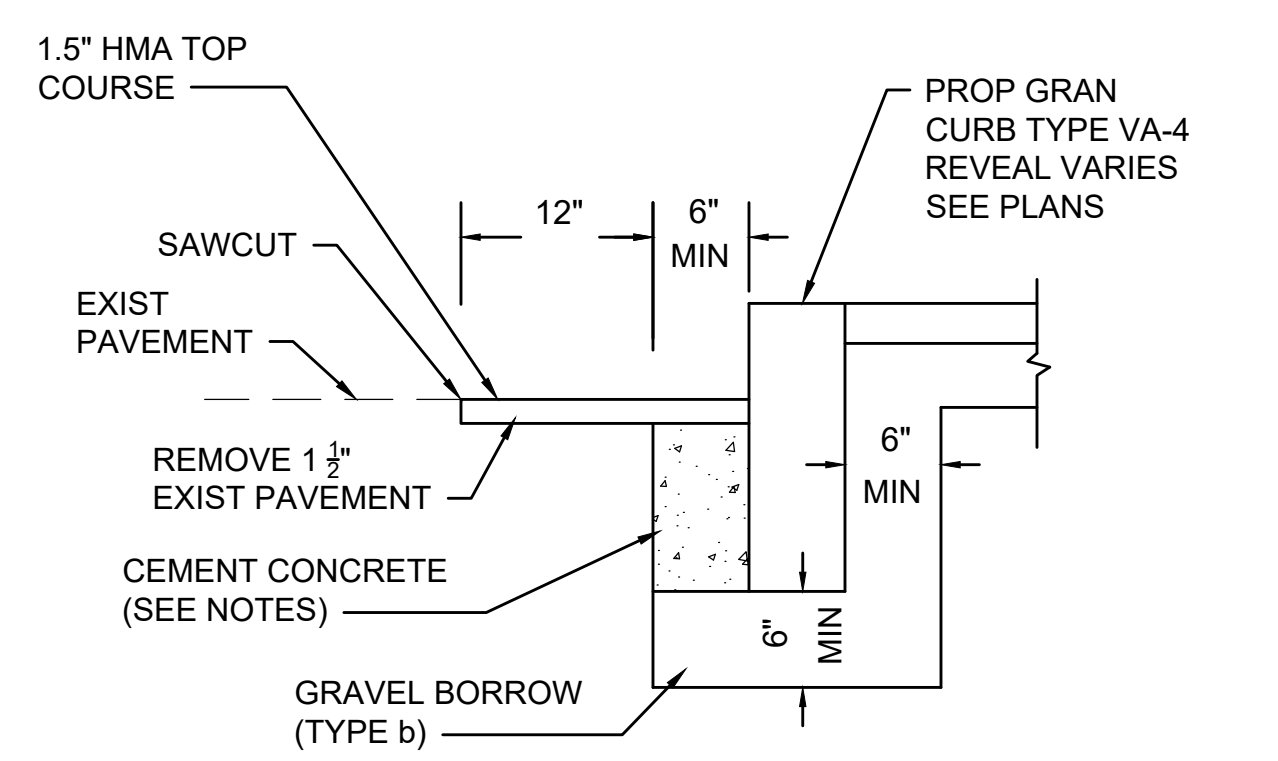

- NOTES:
1. CONCRETE SHALL BE INCLUDED IN PRICE BID FOR GRANITE CURB.
 2. ANY DESIGNATED CEMENT CONCRETE THAT IS ACCEPTABLE UNDER SECTION M4 OF THE STANDARD SPECIFICATIONS MAY BE USED. ALL TEST REQUIREMENTS ARE WAIVED. HOT MIX ASPHALT SHALL NOT BE USED AS A SUBSTITUTE.

GRANITE CURB IN EXISTING PAVEMENT
SCALE: N.T.S.

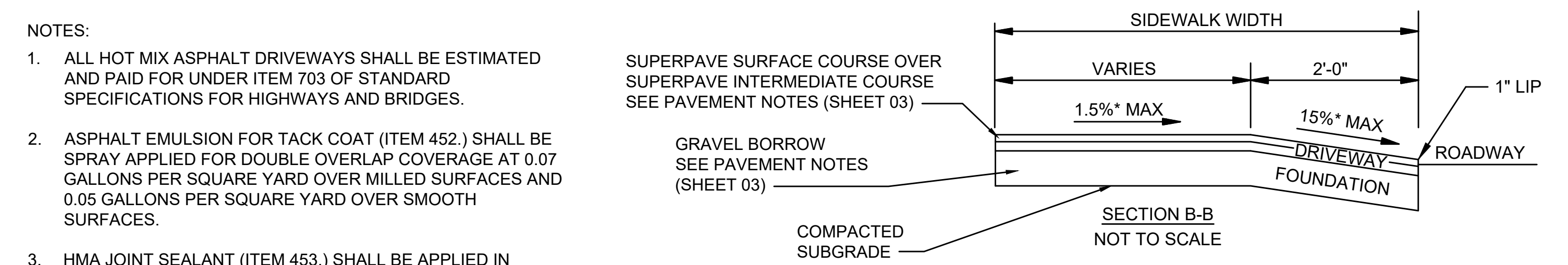

- NOTES:
1. ALL HOT MIX ASPHALT DRIVEWAYS SHALL BE ESTIMATED AND PAID FOR UNDER ITEM 703 OF STANDARD SPECIFICATIONS FOR HIGHWAYS AND BRIDGES.
 2. ASPHALT EMULSION FOR TACK COAT (ITEM 452.) SHALL BE SPRAY APPLIED FOR DOUBLE OVERLAP COVERAGE AT 0.07 GALLONS PER SQUARE YARD OVER MILLED SURFACES AND 0.05 GALLONS PER SQUARE YARD OVER SMOOTH SURFACES.
 3. HMA JOINT SEALANT (ITEM 453.) SHALL BE APPLIED IN SURFACE COURSE AT ALL VERTICAL COLD JOINTS PRIOR TO HMA PAVING.

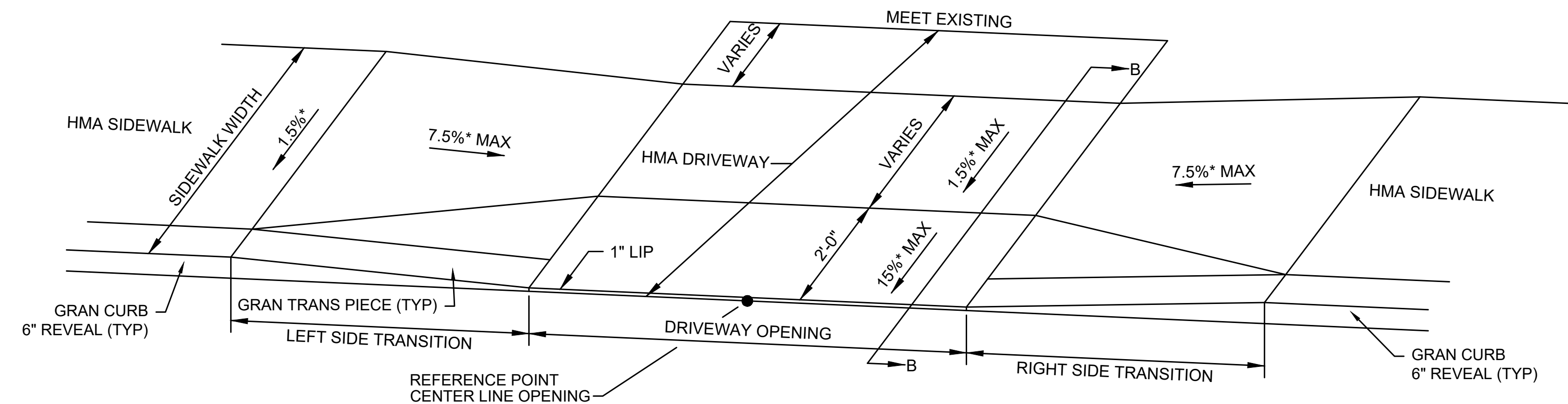

* = TOLERANCE FOR CONSTRUCTION ±0.5%

HOT MIX ASPHALT DRIVEWAY
SCALE: N.T.S.

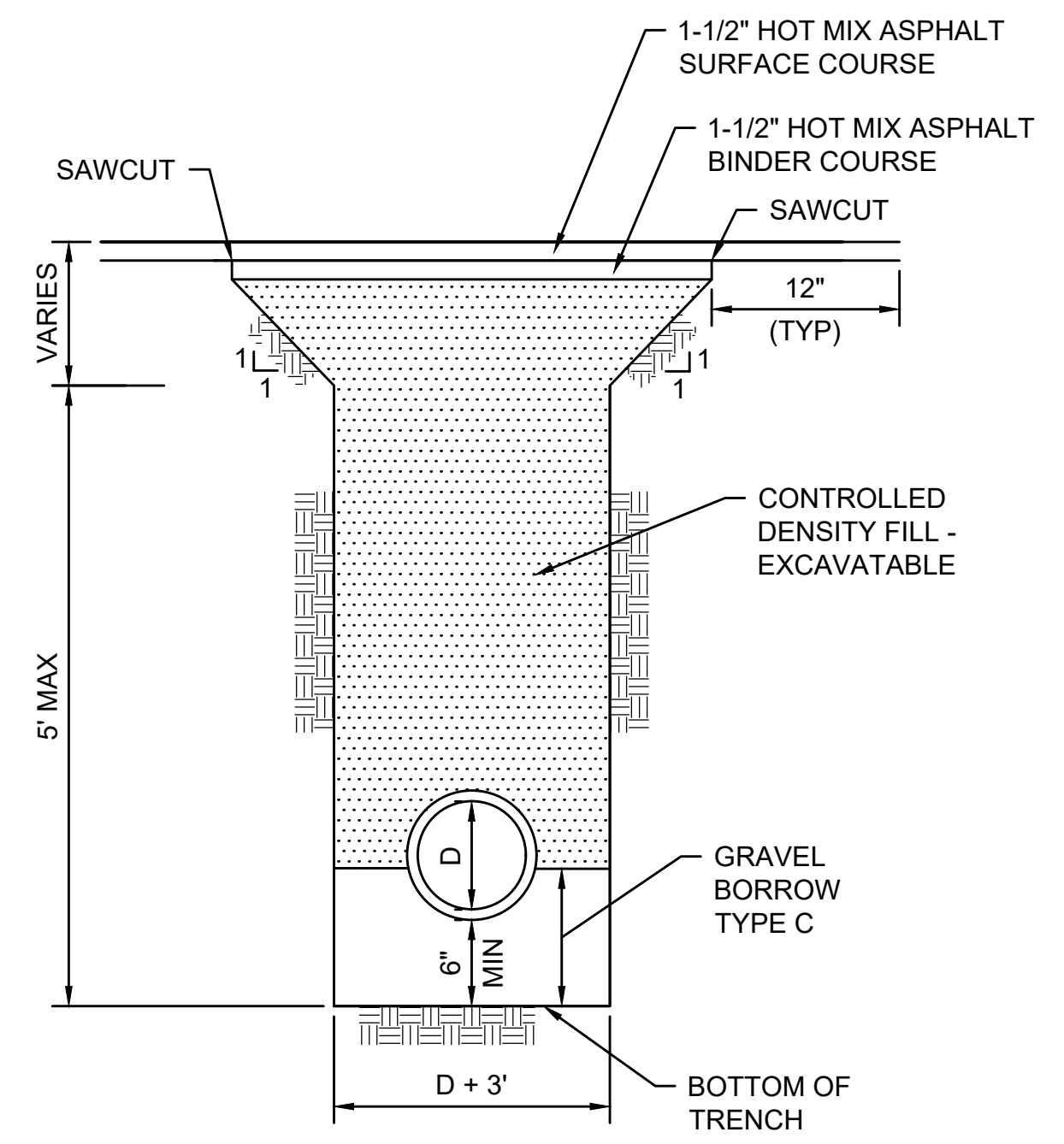

TRENCH DETAIL IN EXISTING HOT MIX ASPHALT

SCALE: N.T.S. DWG: TRENCH-04 DATE: MARCH 2013

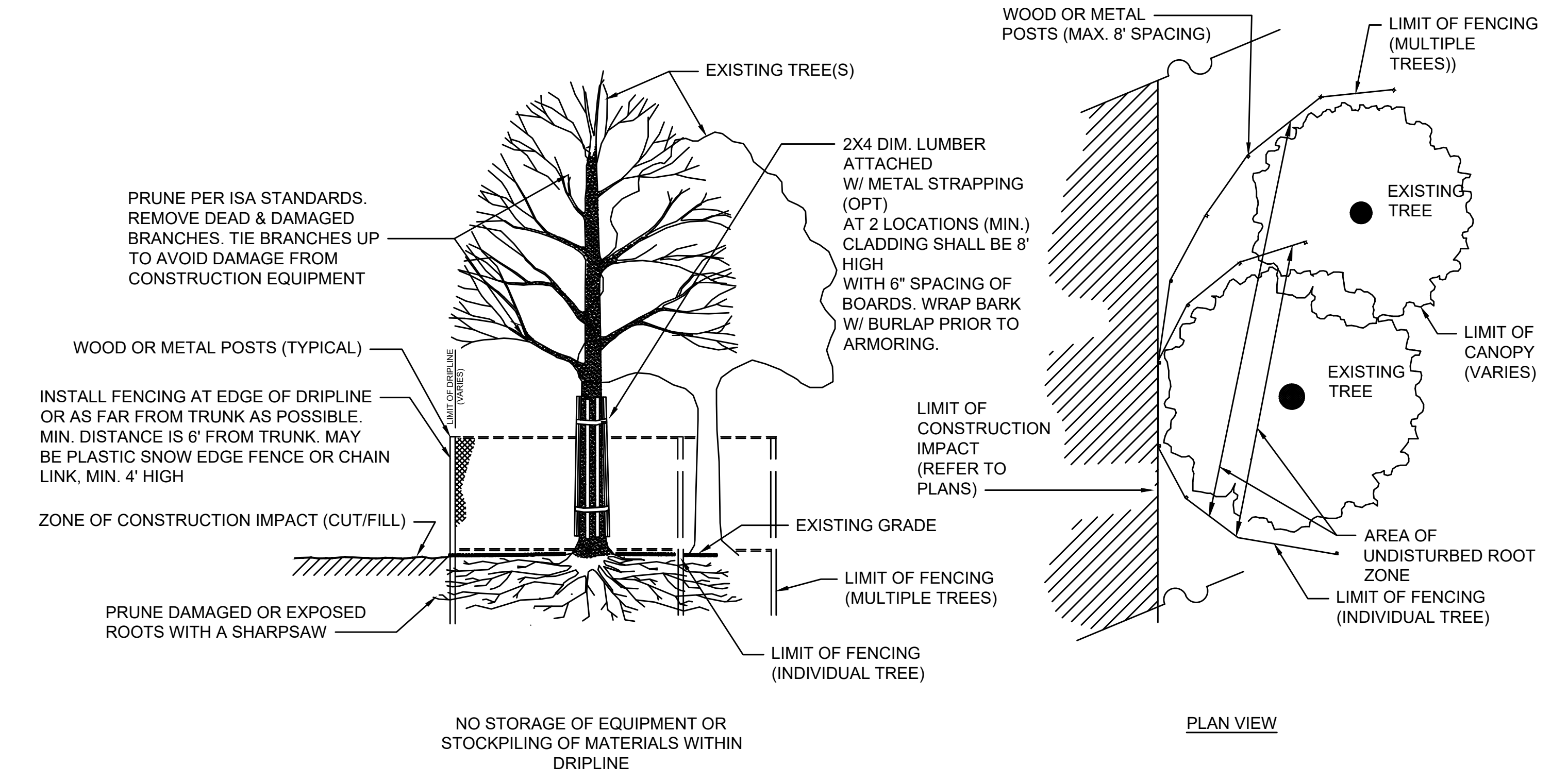

TREE PROTECTION OF EXISTING TREE(S)

SCALE: N.T.S.

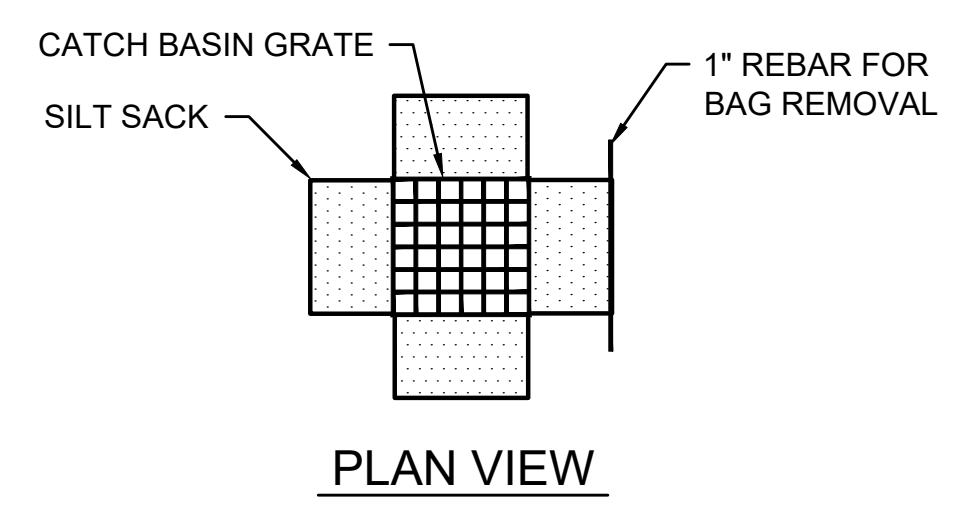

PLAN VIEW

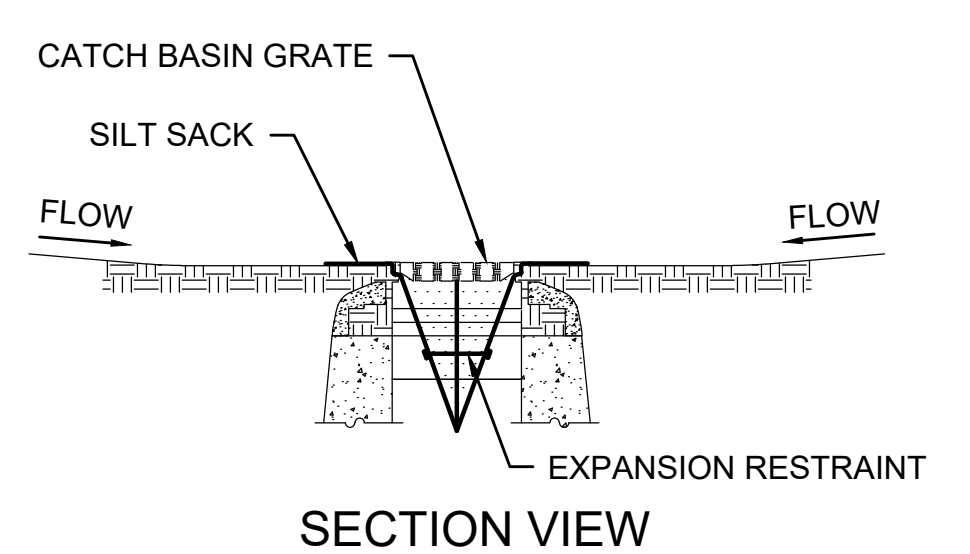

SECTION VIEW

- NOTES:
1. INSTALL SILT SACK IN EXISTING CATCH BASINS, BEFORE COMMENCING WORK, AND IN NEW CATCH BASINS IMMEDIATELY AFTER INSTALLATION OF STRUCTURE. MAINTAIN UNTIL BINDER COURSE PAVING IS COMPLETE OR A PERMANENT STAND OF GRASS HAS BEEN ESTABLISHED.
 2. GRATE TO BE PLACED OVER SILT SACK.
 3. SILT SACK SHALL BE INSPECTED PERIODICALLY AND AFTER ALL STORM EVENTS AND CLEANING OR REPLACEMENT SHALL BE PERFORMED

INLET PROTECTION - SILT SACK IN CATCH BASIN

SCALE: N.T.S.

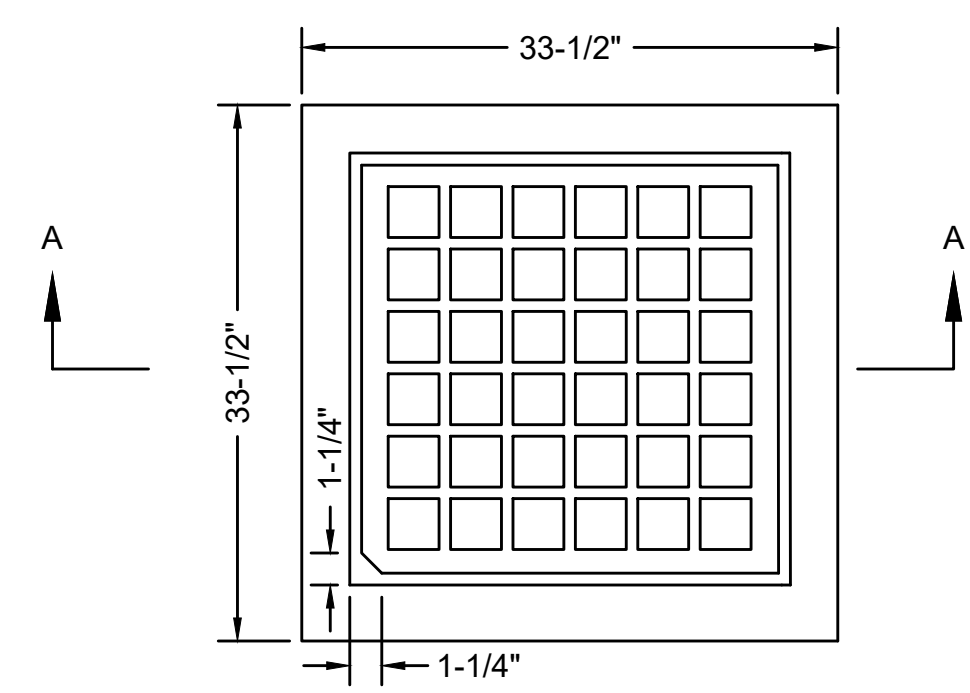

PLAN

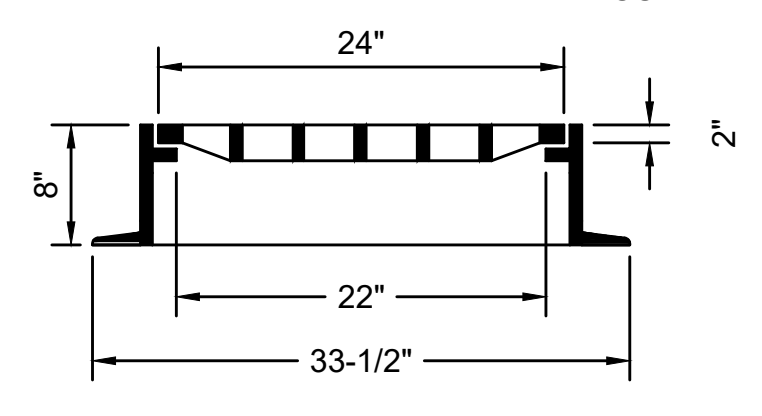

SECTION

- NOTES:
1. FRAME AND GRATE SHALL BE RATED FOR HS-20 LOADING.
 2. MIN FRAME WEIGHT:
4 FLANGE 295 LBS.
3 FLANGE 265 LBS.
 3. USE 3 FLANGE FRAMES AT CURB INLETS.

MUNICIPAL STANDARD CATCH BASIN FRAME & GRATE

SCALE: N.T.S.

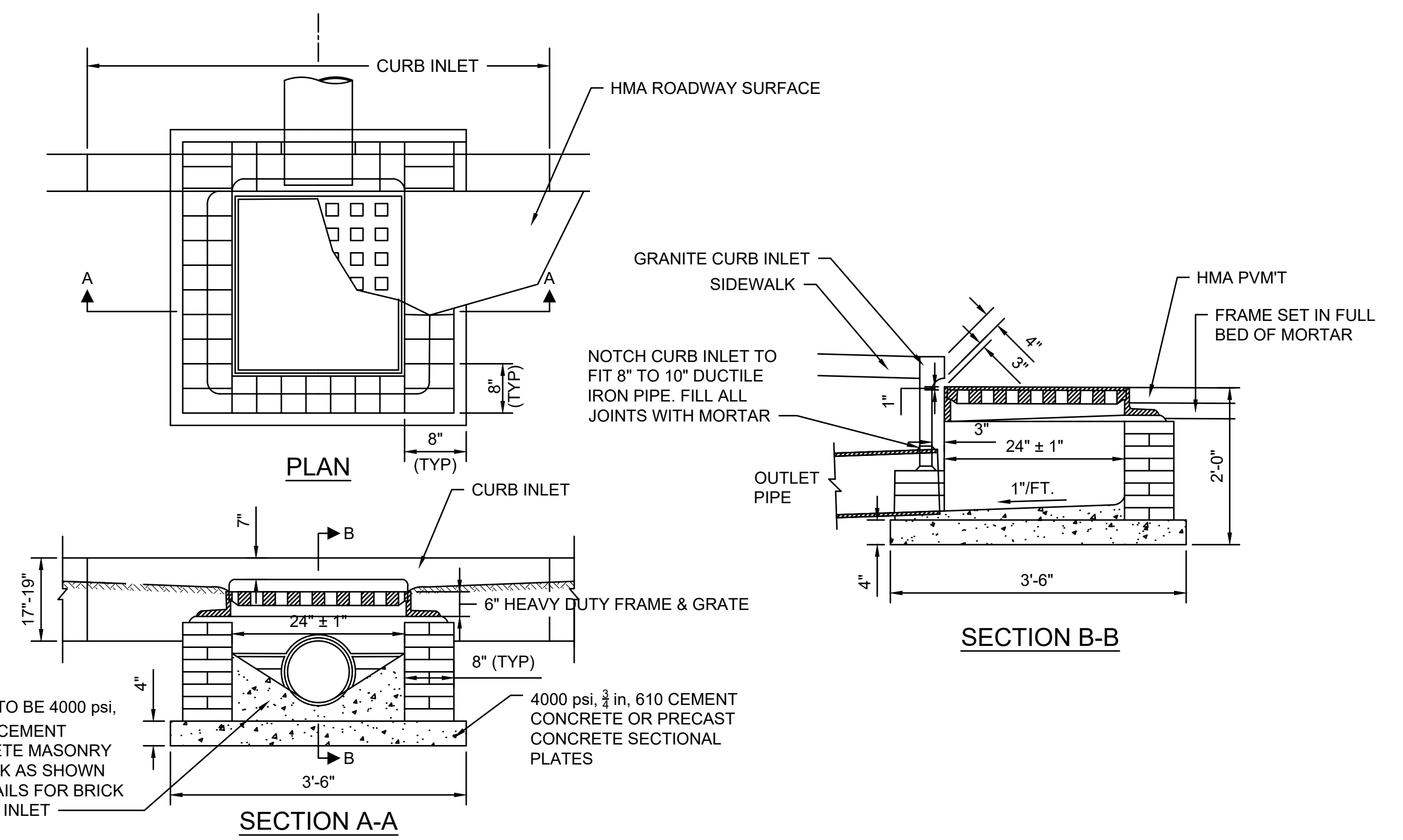

GUTTER INLET - SPECIAL

SCALE: N.T.S.